

COLOR INKJET PRINTER

TX300P-1800B

OPERATION MANUAL

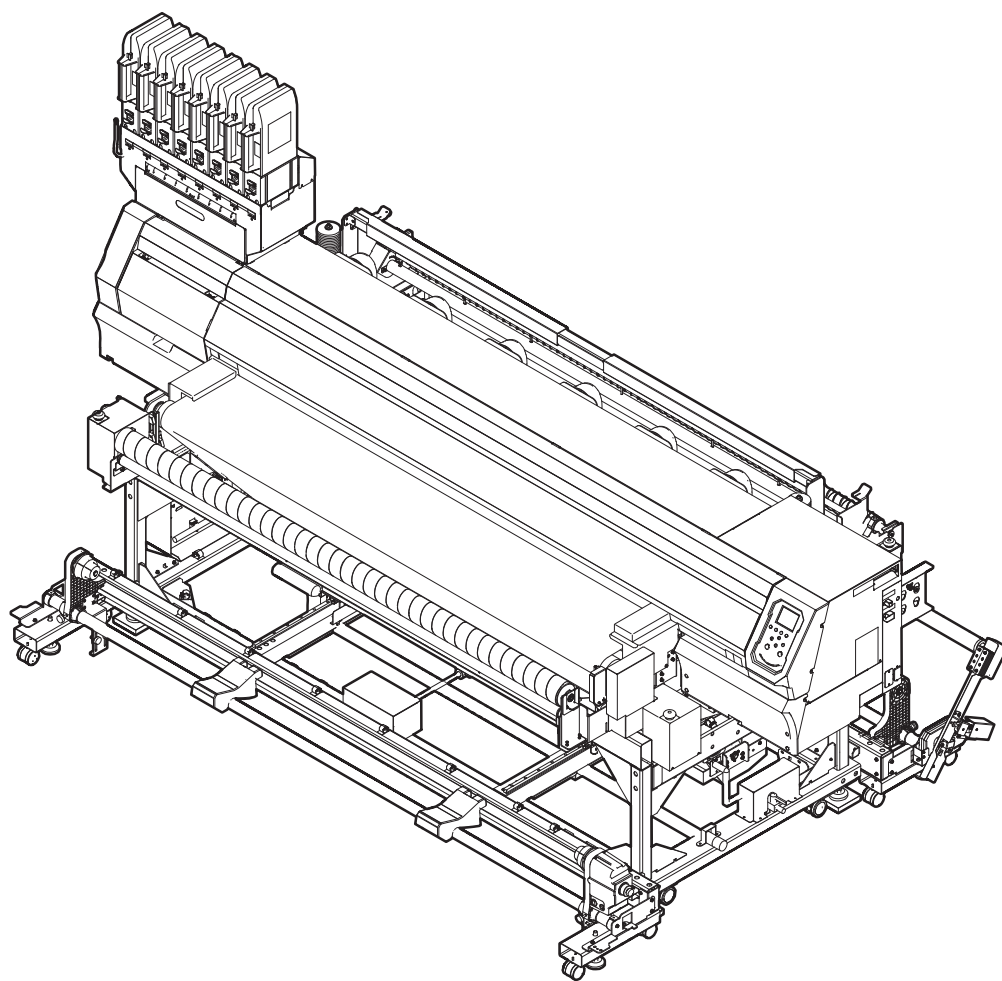

You can also download the latest manual from our website.

MIMAKI ENGINEERING CO., LTD.

URL: <http://mimaki.com/>

TABLE OF CONTENTS

CAUTION	v
DISCLAIMER OF WARRANTY	v
Requests	v
FCC Statement (USA)	v
Interference to televisions and radios	v
Foreword	v
About usable ink	v
On This Operation manual	v
Safety Precautions	vi
Symbols	vi
Safety interlock	ix
Emergency Stop Switches	ix
Warning labels	x

Chapter 1 Before Use

Moving This Machine	1-2
Where to Install This Machine	1-2
Working Environmental Temperature.....	1-2
Moving This Machine	1-2
Names of Parts and Functions	1-4
Front Side of the Machine	1-4
Rear Side and Right Side of the Machine	1-5
Operation Panel	1-6
Carriage.....	1-8
Capping station	1-8
Connecting Cables	1-8
Connecting USB2.0 Interface Cable	1-8
Connecting the LAN cable.....	1-9
Connecting the power cable.....	1-10
Setting Ink	1-10
Caution in handling of ink packs.....	1-13
Media	1-14
Usable sizes of media	1-14
Caution in handling of medias	1-14
Limited media	1-15
Menu mode	1-16

Chapter 2 Basic Operations

Workflow	2-2
Turning the Power ON/OFF	2-3
Turning the Power ON.....	2-3
Turning the Power OFF.....	2-3
Setting a Media	2-4
Setting Feeding and Take-up unit	2-4
Adjusting the Head Height.....	2-5
Printing Width	2-6

Mounting the fabric roller	2-6
Using the tension bar to set the roll media	2-7
Setting roll media without using tension bar	2-12
Using the peeling to set the media	2-14
Setting media without using peeling	2-14
Feeding/ Take-up device	2-17
Changing the printing origin	2-20
Pressure roller weight adjustment	2-20
Peeling sensor positioning adjustment	2-21
Eradicating Media Sagging with the Curved Bar	2-22
Removing the smoother roller and replacing frames	2-23
Test Printing	2-24
Test Printing	2-24
Set the media feeding	2-26
Flow of media feeding correction	2-26
Head Cleaning	2-27
About head cleaning	2-27
Perform head cleaning depending on the test printing result	2-27
Setting of Media Correction	2-27
Setting of Media Correction	2-27
If the Positions of Dots Shift... ..	2-28
Printing Data	2-28
Starting a Printing Operation	2-28
Stopping a Printing Operation	2-29
Deleting Received Data (Data Clear)	2-29
Behavior after printing has been completed	2-29
To reduce waste of media	2-29

Chapter 3

Setup

About SETUP MENU	3-2
SETUP MENU table	3-3
Register the optimal print conditions to match the use	3-4
Setting of Media Correction	3-5
If the Positions of Dots Shift... ..	3-6
Setting of Logical Seek	3-7
Setting of Overprint	3-7
Setting of Drying Time	3-8
Setting of Feed Speed	3-8
Setting of MAPS4	3-9
Setting Auto Cleaning	3-10
Setting Interval wiping	3-11
Setting External heater	3-11
Setting for Improving Image Quality by Changing Media-feeding Rate (BELT COMP.)	3-11
Setting Belt Wash	3-11
Setting Maintenance Notification Time (COUNTER LIMIT)	3-12
About MACHINE SETUP MENU	3-13
MACHINE SETUP MENU table	3-14
Setting a AUTO Power-off	3-15
Setting Top Blower	3-15

Setting the Display of Media Residual.....	3-16
Setting the PG Drop Adjust	3-16
Setting the Media Detection	3-16
Setting the Drying Feed.....	3-17
Setting a LANGUAGE	3-17
Setting Time	3-17
Setting Unit (Temperature/ Length).....	3-18
Setting a KEY BUZZER.....	3-18
Setting the VIEW FEED	3-18
Setting the SPACE FEED MODE.....	3-18
Set the network	3-19
Setting event mail function	3-19
Initializing the Settings.....	3-23
About NOZZLE CHECK MENU	3-24
INFORMATION MENU table.....	3-24
Printing Check Flow	3-25
Printing Operations at “Nozzle Missing” Judgment and Error Occurrence 3-25	
Setting the Printing Check.....	3-26
Setting the NOZZLE RECOVERY	3-26
Setting the Judgement Condition	3-26
About INFORMATION MENU	3-27
INFORMATION MENU table.....	3-27
Displaying the Information.....	3-28

Chapter 4 Maintenance

Maintenance	4-2
Precautions for Maintenance.....	4-2
About Cleaning Solution	4-2
Cleaning the Exterior Surfaces.....	4-2
Cleaning the peeling roller.....	4-2
Cleaning the Belt Correction Unit.....	4-3
About MAINTENANCE MENU	4-4
MAINTENANCE MENUs at-a-glance.....	4-5
Maintaining the Capping Station	4-6
Cleaning the Wiper and Cap	4-6
Washing the Head Nozzle.....	4-7
Washing the Ink Discharge Passage	4-9
When the Machine Is Not Used for a Long Time	4-10
Cleaning the Ink Head and the Area around It	4-13
Nozzle Recovery Function	4-14
Reset the set value.....	4-15
Check the condition for which nozzle recovery cannot be performed.	4-15
Enabling or disabling nozzle recovery during a test print.....	4-16
Automatic Maintenance Function	4-16

Setting the Refreshing Intervals	4-16
Setting the Tube Wash Intervals	4-17
Setting the Cleaning Intervals and Type	4-17
Suspend the nozzle cleaning	4-17
Fill up Ink	4-18
Replacing consumables	4-18
Replacing the wiper	4-18
Replacing the Spout Rubber	4-19
If a Waste Ink Tank Confirmation Message Appears	4-21
Replace the waste ink tank with another	4-21
Replacing the Water	4-22
Wash Unit Maintenance	4-23
Cleaning the Belt Wash Unit	4-23
Absorb Roller Cleaning	4-24
Reapplying Adhesive	4-26
Peeling Off Adhesive	4-26
Applying Adhesive	4-28
Cleaning the washing tray and brush	4-31
Feeding Belt Cleaning	4-32
Peeling Sensor Cleaning	4-33
Resetting the Counter	4-33

Chapter 5

Troubleshooting

Troubleshooting	5-2
Power does not turn on	5-2
The machine does not start printing	5-2
Media get jammed / media is soiled	5-2
Image quality is poor	5-3
Nozzle is clogged	5-3
Ink IC warning appears	5-3
When the ink leakage occurs	5-3
Warning / Error Messages	5-4
Warning messages	5-4
Error messages	5-8

Chapter 6

Appendix

Specifications	6-2
Machine specifications	6-2
Ink specifications	6-3
Setting orders depending on ink type	6-4
Setting orders of ink cartridges	6-4
Sheet for inquiry	6-5

CAUTION

DISCLAIMER OF WARRANTY

THIS LIMITED WARRANTY OF MIMAKI SHALL BE THE SOLE AND EXCLUSIVE WARRANTY AND IS IN LIEU OF ALL OTHER WARRANTIES, EXPRESS OR IMPLIED, INCLUDING, BUT NOT LIMITED TO, ANY IMPLIED WARRANTY OF MERCHANTABILITY OR FITNESS, AND MIMAKI NEITHER ASSUMES NOR AUTHORIZES DEALER TO ASSUME FOR IT ANY OTHER OBLIGATION OR LIABILITY OR MAKE ANY OTHER WARRANTY OR MAKE ANY OTHER WARRANTY IN CONNECTION WITH ANY PRODUCT WITHOUT MIMAKI'S PRIOR WRITTEN CONSENT.

IN NO EVENT SHALL MIMAKI BE LIABLE FOR SPECIAL, INCIDENTAL OR CONSEQUENTIAL DAMAGES OR FOR LOSS OF PROFITS OF DEALER OR CUSTOMERS OF ANY PRODUCT.

Requests

- This Operation manual has been carefully prepared for your easy understanding.
However, please do not hesitate to contact a distributor in your district or our office if you have any inquiry.
- Description contained in this Operation manual are subject to change without notice for improvement.

FCC Statement (USA)

This equipment has been tested and found to comply with the limits for a Class A digital device, pursuant to Part 15 of the FCC Rules. These limits are designed to provide reasonable protection against harmful interference when the equipment is operated in a commercial environment. This equipment generates, uses and can radiate radio frequency energy and, if not installed and used in accordance with the Operation manual, may cause harmful interference to radio communications.

Operation of this equipment in a residential area is likely to cause harmful interference in which case the user will be required to correct the interference at his own expense.

In the case where MIMAKI-recommended cable is not used for connection of this device, limits provided by FCC rules can be exceeded.

To prevent this, use of MIMAKI-recommended cable is essential for the connection of this printer.

Interference to televisions and radios

The product described in this manual generates high frequency when operating.

The product can interfere with radios and televisions if set up or commissioned under improper conditions.

The product is not guaranteed against any damage to specific-purpose radio and televisions.

The product's interference with your radio or television will be checked by turning on/off the power switch of the product.

In the event that the product is the cause of interference, try to eliminate it by taking one of the following corrective measures or taking some of them in combination.

- Change the orientation of the antenna of the television set or radio to find a position without reception difficulty.
- Separate the television set or radio from this product.
- Plug the power cord of this product into an outlet which is isolated from power circuits connected to the television set or radio.

Foreword

Congratulations on your purchase of MIMAKI color inkjet printer "Tx300P-1800B".

"Tx300P-1800B" is a color inkjet printer that can print on 1.9m-width media with sublimation dye ink (4-color, 6-color and 8-color).

About usable ink

You can use aqueous sublimation dye ink/ Disperse dye ink/ Pigment ink for textile/ Acid-dye ink/ Reactive-dye ink for this machine.



- For usable ink, refer to P.6-3 "Ink specifications" and P.6-4 "Setting orders of ink cartridges".

On This Operation manual

- This Operation manual is describing the operations and maintenance of "Color inkjet printer Tx300P-1800B" (called as this machine hereafter)
- Read this Operation manual carefully and understand them thoroughly to use.
- It is also necessary to keep this Operation manual on hand.
- This Operation manual has been carefully prepared for your easy understanding, however, please do not hesitate to contact a distributor in your district or our office if you have any inquiry.
- Descriptions contained in this Operation manual are subject to change without any notice for improvement.
- In the case when this Operation manual should be illegible due to destruction or lost by fire or breakage, purchase another copy of the Operation manual from our office.
- You can also download the latest manual from our website.

Reproduction of this manual is strictly prohibited.

All Rights Reserved. Copyright

© 2016 MIMAKI ENGINEERING Co., Ltd.

Safety Precautions

Symbols

Symbols are used in this Operation Manual for safe operation and for prevention of damage to the machine. The indicated sign is different depending on the content of caution.

Symbols and their meanings are given below. Please follow these instructions as you read this manual.

Examples

Explanation	
	Failure to observe the instructions given with this symbol can result in death or serious injuries to personnel. Be sure to read it carefully and use it properly.
	Failure to observe the instructions given with this symbol can result in injuries to personnel or damage to property.
	Important notes in use of this machine are given with this symbol. Understand the notes thoroughly to operate the machine properly.
	Useful information is given with this symbol. Refer to the information to operate the machine properly.
	Indicates the reference page for related contents.
	The symbol “” indicates that the instructions must be observed as strictly as the CAUTION instructions (including DANGER and WARNING instructions). A sign representing a precaution (the sign shown at left warns of hazardous voltage) is shown in the triangle.
	The symbol “” indicates that the action shown is prohibited. A sign representing a prohibited action (the sign shown at left prohibits disassembly) is shown in or around the circle.
	The symbol “” indicates that the action shown must be taken without fail or the instructions must be observed without fail. A sign representing a particular instruction (the sign shown at left instructs to unplug the cable from the wall outlet) is shown in the circle.

Warning for Use

WARNING

- The set of power cables provided with this machine is for use with this machine only, and cannot be used with other electrical devices. Do not use any power cables other than the ones provided with the machine. Failure to observe those instructions may result in fire or electric shocks.







WARNING





- Take care not to damage, break or work upon the power cable. If a heavy material is placed on the power cable, or if it is heated or pulled, the power cable can break, thus resulting in fire or electric shocks.
- Do not use this machine in an environment where humidity is high or the machine may get wet. Using the machine under such environment may result in fire or electric shock, or cause malfunction.
- Use of the machine under an abnormal condition where it produces smoke or strange smell can result in fire or electric shocks. If such an abnormality is found, be sure to turn off the power switch immediately and unplug the cable from the wall outlet. Check first that the machine no longer produces smoke, and then contact your distributor or a sales office of MIMAKI for repair. Never repair your machine by yourself since it is very dangerous for you to do so.
- In case of ink leakage, please turn off the main power, unplug the power cable and contact your local distributor, our sales office, or service center.
- As a fire is strictly prohibited at the time of repainting adhesive, make sure to turn off the power of circumjacent devices (such as a heater). In addition, please perform ventilation by all means.
- Never disassemble or remodel the main unit of the machine or the ink cartridge. Disassembly or remodeling can result in an electric shock or breakdown of the machine.
- Do not use extension cords. Doing so may result in fire or electric shocks.
- Keep the power plug prong clear of any foreign object such as a piece of metal. Failure to do so may result in a fire or electric shocks.
- Do not plug too many leads into a single socket. Doing so may result in fire or electric shocks.
- Do not use the machine if the power cord or plug is damaged. Using the machine with damaged power cord may result in fire or electric shocks. Contact your service representative for replacement cord.
- Do not handle the power plug with wet hands. Doing so may result in electric shocks.
- Grasp by holding the plug itself when removing the power plug from wall outlet, and never hold by the cord. Holding and pulling the cord may damage the cord, leading to fire or electric shocks.
- To move the equipment, contact the nearest service shop.

Hazardous Moving Parts

- Keep Fingers and Other Body Parts Away
- If a foreign object such as a small piece of metal or a liquid such as water gets inside the machine, turn off the machine and unplug the power cord immediately, then consult your service representative. Continuing to use the machine without proper maintenance or repair may result in fire or electric shocks.

Precautions in Use

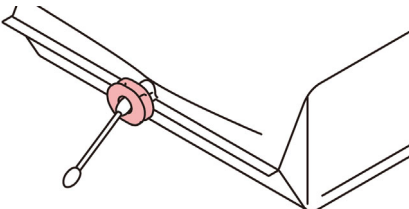
 CAUTION	
Power supply	
	<ul style="list-style-type: none"> • Leave the breaker turned ON. • Do not turn off the main power switch on the right side of this machine.
Handling of the power cable	
	<ul style="list-style-type: none"> • Connect to a socket-outlet with determinate polarity. • For PLUGGABLE EQUIPMENT, the socket-outlet shall be installed near the equipment and shall be easily accessible. • Unplug the cord from the wall outlet and remove dust from the power plug periodically, at least once a year. Failure to do so may result in fire or electric shocks.
Note on maintenance	
	<ul style="list-style-type: none"> • When cleaning the ink-station or the heads, be sure to wear the included safety glasses and gloves. • When handling ink and cleaning solution, pay close attention to ventilation and be sure to wear the included safety glasses and gloves. • The gloves supplied with the machine are disposable. When all the gloves are expended, purchase an equivalent product on the market.
	
Notes When Handling this machine	
	<ul style="list-style-type: none"> • Use the equipment in a well-ventilated or not-airtight room. • Ventilate the room sufficiently before using the equipment. • Do not place the equipment in a humid or dusty place. Otherwise, there is a risk of fire or electrical shock. • Do not place the equipment in an unstable place such as on a shaky table and on a tilted surface. The equipment may fall over or drop and cause injury. • To replace a printing media, be careful not to pinch your fingers or get injured. • Consult with the service shop about cleaning inside the equipment. Leaving the equipment with dust inside without cleaning for a long time may cause a fire or device failure. Consult with the distributor or service shop for the cost of cleaning inside the equipment.
Handling of ink packs	
	<ul style="list-style-type: none"> • Before using ink and cleaning solution, be sure to read the Safety Data Sheet (SDS). • Keep ink away from an open flame. Also keep the room well ventilated when you use or handle ink. • If you get ink in your eyes, immediately wash your eyes with a lot of clean water for at least 15 minutes. In doing so, also wash eyes to rinse ink away completely. Then, consult a doctor as soon as possible. • If anyone drinks ink by mistake, keep him or her quiet and see a doctor immediately. Do not allow him or her to swallow the vomit. Then contact the emergency number written in SDS.

 CAUTION	
	<ul style="list-style-type: none"> • If you inhale a great deal of vapor and feel ill, immediately move to a location with plenty of fresh air, and keep yourself warm and quiet. Consult a doctor as soon as possible. • If the ink adheres to your skin, use a large amount of water and soap or special detergent for skin to remove the ink. • Be sure to store ink packs out of reach of children. • Do not leave the ink slot empty for a long time. Leaving it empty may dry the slot and solidify the ink in the machine, then the machine will become unable to supply ink. • If ink packs are not set in the ink slot, an error message will display on the printer to set ink packs. Set the same colored ink cartridge as the ink used before. • When you removed the ink pack from the seat before it ends, wipe ink adhering to inside of the connector part of the ink pack with a cotton swab etc. If ink adhering to inside of the connector part may dry out, it may cause ink leakage when using it again.
	
	<ul style="list-style-type: none"> • When removing eco-case from the seat, be sure to wear safety glasses etc. Ink may spatter and get in your eyes. Do not pull out and insert the middle cartridge again as much as possible.

CAUTIONS and NOTES

 Warning	
Disposition of this machine	
<ul style="list-style-type: none"> • Consult your sales or service representative for proper disposal of this machine. Otherwise, commission an industrial waste disposal company. 	
Protection of media from dust	
<ul style="list-style-type: none"> • Store media in a bag. Wiping off dust accumulated on media will adversely affect the media due to static electricity. • When leaving the workshop after the working hours, do not leave any media on the roll hanger. If any media is left on the roll hanger, it can get dusty. 	
Periodic replacement parts	
<ul style="list-style-type: none"> • Some parts of this machine must be replaced with a new one periodically by service personnel. Be sure to make a contract with your distributor or dealer for After sale service to ensure a long life of your machine. 	

 **Warning**

Handling of media

- Use media recommended by MIMAKI to ensure reliable, high-quality printing.
- Pay attention to the expansion and contraction of the media. Do not use media immediately after unpacking. The media can be affected by the room temperature and humidity, and thus it may expand and contract. The media have to be left in the atmosphere in which they are to be used for 30 minutes or more after unpacked.
- Do not leave the media with the heater ON for a long time.

Handling of ink packs





- The safety evaluation of this machine assumes that the ink recommended by this company is used. For safe usage of this machine, use the ink recommended by this company
- Never refill the ink pack with ink. Refilled ink pack can cause a trouble. Remember that MIMAKI assumes no responsibility for any damage caused by the use of the ink pack replenished with ink.
- If the ink pack is moved from a cold place to a warm place, leave it in the room temperature for three hours or more before using it.
- Open the ink pack just before installing it in the machine. If it is opened and left for an extended period of time, normal printing performance of the machine may not be ensured.
- Make sure to store ink packs in a cool and dark place.
- Store ink packs and waste ink bottle in a place that is out of the reach of children.
- Be sure to thoroughly consume the ink in the ink pack, once it is opened, within three months. If an extended period of time has passed away after opening the cartridge tank, printing quality would be poor.
- Neither pound the cartridge nor shake it violently, as doing so can cause leakage of ink.
- Consult your sales or service representative for proper disposal of ink cartridge, ink pack, and waste ink. When you dispose them by yourself, follow the regulations stipulated by the industrial waste disposer or the country or region you live in.
- When you dispose the belt washing liquid, ask the industrial waste disposer to proceed or do by yourself following the local regulations of each country.

Notes on maintenance

- It is strongly recommended to use the machine in a room that is not dusty.
- Keep the front cover closed even when the machine is not printing. If not, dust can accumulate on the nozzles in the heads. Dust in the heads can also cause drops of ink to fall suddenly down on the media during printing. In such a case, be sure to clean up the heads.
- When cleaning the ink-station or the heads, make sure to wear the attached gloves and safety glasses.
- Perform wiping (removal of dust and paper powder) of the capping station and wiper frequently.

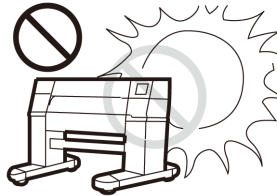
Cautions on Installation

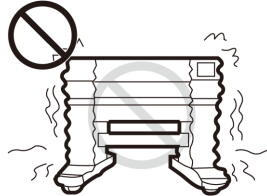
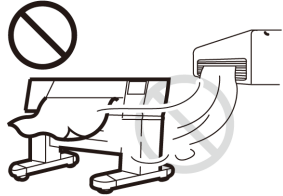
 **CAUTION**

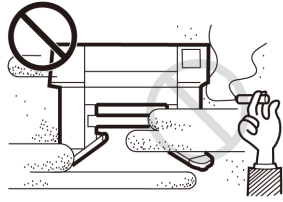
A place exposed to direct sunlight	On an inclined surface
	
A place that vibrates	A place exposed to direct air flow from an air conditioner or the like.
	
A place where temperature or humidity varies significantly	Around a place where fire is used
 <ul style="list-style-type: none"> • Use the machine under the following environmental conditions: • Operating environment: 20 to 30 °C (68 to 86 °F) 35 to 65 % (Rh) 	

Safety interlock

This machine is equipped with interlocks to terminate the operation for your safety when the cover opens during printing etc. (red circle parts in the figure below).

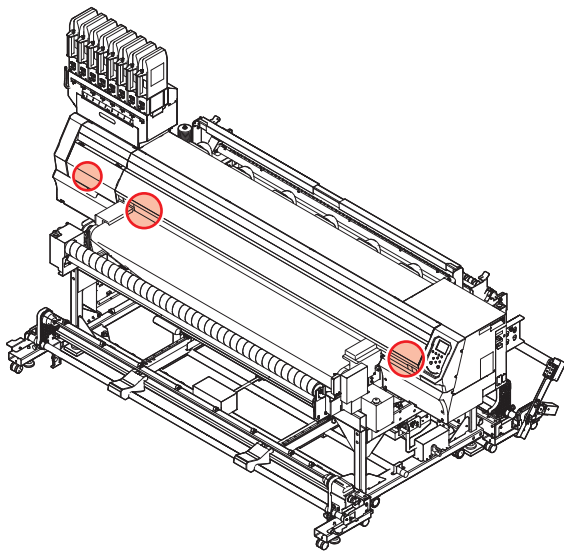

Emergency Stop Switches

Press this button when an emergency stop is necessary for safety purposes. Two emergency stop switches are located on the front panel, and two on the rear panel.

Front

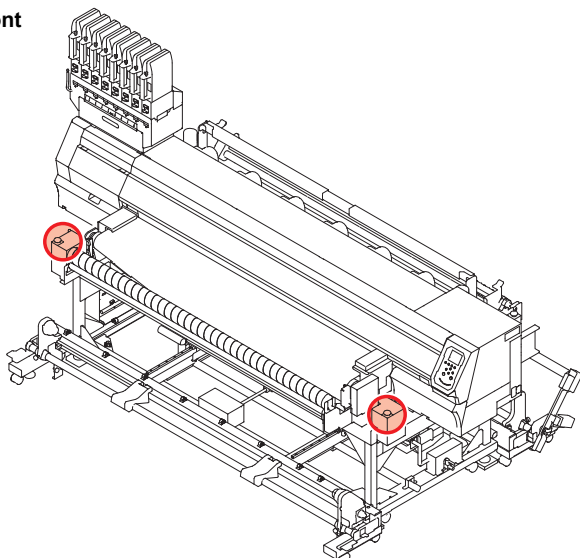

Rear

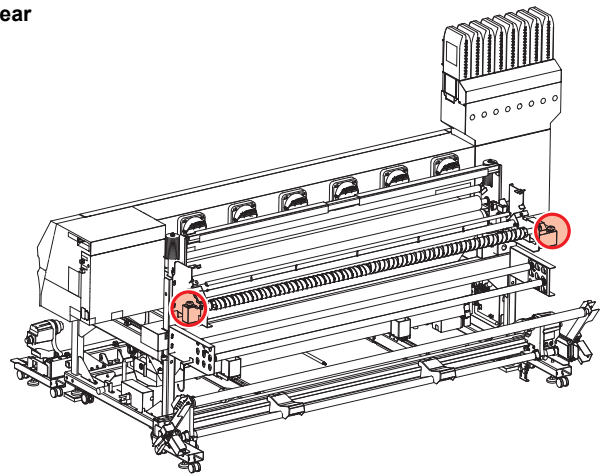

Important!

- Carry out the following procedure if the emergency stop button has been pressed.
 - (1) Disconnect the power plug from the plug socket and rectify the problem.
 - (2) Deactivate the emergency stop switch once safety has been confirmed.

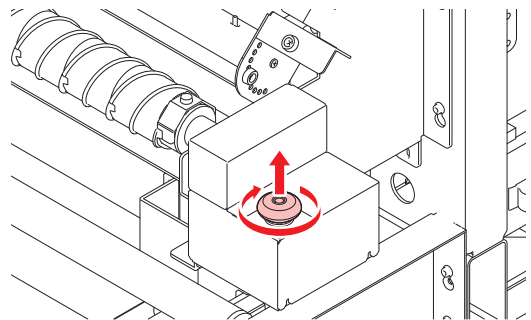



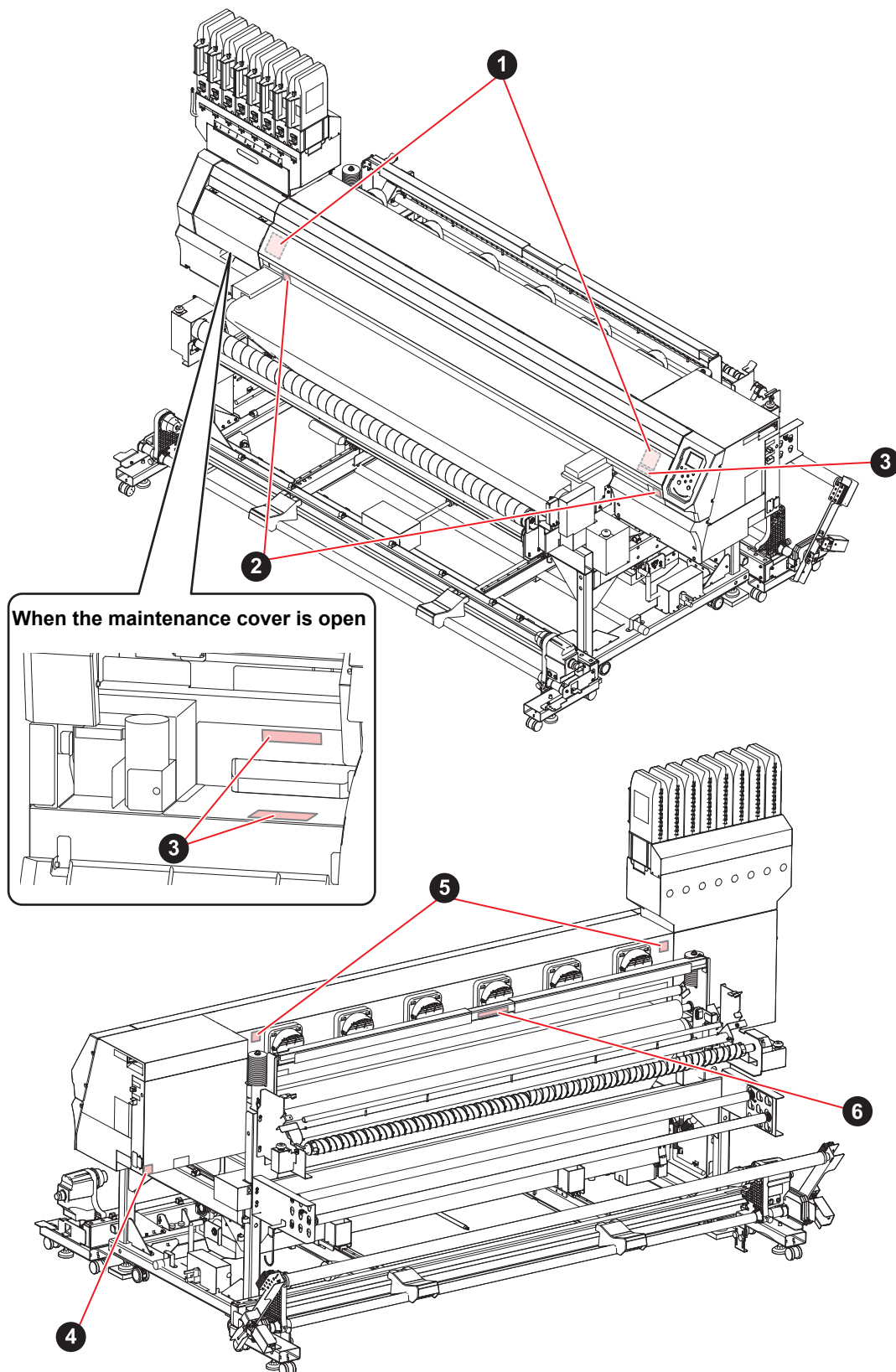

- (3) Connect the power plug to the plug socket.

Warning labels

Warning labels are stuck on the machine. Be sure to fully understand the warning given on the labels. If a warning label is illegible due to stains or has come off, purchase a new one from a distributor or our sales office.

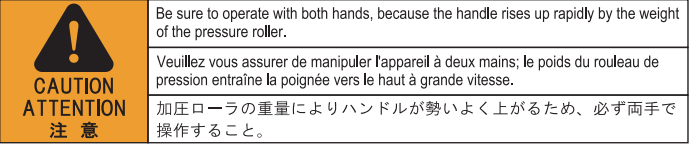

No.	Reorder	Label
1	M910931	 <p>CAUTION ATTENTION</p> <p>COVER HAZARD May result in severe injury. When open and close the cover, hold a cover until the end.</p> <p>COUVERCLE-DANGER Peut entraîner de graves blessures. Lors de l'ouverture ou de la fermeture du couvercle, tenir le couvercle jusqu'à la fin.</p> <p>カバー急落下あり 指を挟まれると、ケガや骨折の恐れあり。 カバーの開閉は、最後まで手を添えて行ってください。</p> <p>M910931</p>
2	M907833	
3	M903330	
4	M907935	
5	M913867	 <p>WARNING 警告 警告</p> <p>-HAZARDOUS MOVING PARTS- 危険な可動部 手指和身体请勿靠近运转部位，以免造成危险</p> <p>Keep fingers and other body parts away. 指や体を近づけないように</p> <p>WAARSCHUWING AVERTISSEMENT</p> <p>GEFÄHRLICHE BEWEGLICHE TEILE PIÈCES MOBILES DANGEREUSES</p> <p>Finger und andere Körperteile fernhalten. Doigts et autres parties du corps sont hors de portée.</p>
6	M913939	 <p>CAUTION ATTENTION 注意</p> <p>Be sure to operate with both hands, because the handle rises up rapidly by the weight of the pressure roller.</p> <p>Veuillez vous assurer de manipuler l'appareil à deux mains; le poids du rouleau de pression entraîne la poignée vers le haut à grande vitesse.</p> <p>加圧ローラの重量によりハンドルが勢いよく上がるため、必ず両手で操作すること。</p>

EC DECLARATION OF CONFORMITY

We hereby declare that the following our products conform with the essential health and safety requirements of EC Directives.

Product	Color Inkjet Printer	
Model No.	Tx300P-1800B	
Serial No. covered	AABCDEEE AA: W3, B: 0 to 9, C: any alpha-numeric, D: any alphabet, EEE: 001 to 999	
Manufacturer	MIMAKI ENGINEERING CO.,LTD. 2182-3, Shigeno-otsu, Tomi, Nagano, 389-0512, JAPAN	
Authorised Compiler in the Community	MIMAKI EUROPE B.V. Stammerdijk 7E 1112 AA Diemen, The Netherlands Managing Director Koji Shimizu	
Directives	Machinery Directive	2006/42/EC
	Low Voltage Directive	2014/35/EU
	EMC Directive	2014/30/EU
	RoHS Directive	2011/65/EU

The above products have been evaluated for conformity with above directives using the following European standards. The technical construction file (TCF) for this product is retained at the above Manufacturer's location.

Machinery Directive / Low Voltage Directive	EN ISO12100:2010, EN60204-1:2006+A1, EN60950-1:2006+A11+A1+A12
EMC Directive	EN55022:2010, EN61000-3-2:2006+A1+A2, EN61000-3-3:2008, EN55024:2010
RoHS Directive	EN50581:2012

Chapter 1

Before Use



This chapter

describes the items required to understand before use, such as the name of each part of the machine or the installation procedures.

Moving This Machine	1-2	Connecting USB2.0 Interface Cable	1-8
Where to Install This Machine	1-2	Connecting the LAN cable	1-9
Working Environmental Temperature	1-2	Connecting the power cable	1-10
Moving This Machine	1-2	Setting Ink	1-10
Names of Parts and Functions.....	1-4	Caution in handling of ink packs	1-13
Front Side of the Machine	1-4	Media	1-14
Rear Side and Right Side of the Machine ...	1-5	Usable sizes of media	1-14
Operation Panel	1-6	Caution in handling of medias	1-14
Carriage	1-8	Limited media	1-15
Capping station	1-8	Menu mode	1-16
Connecting Cables.....	1-8		

Moving This Machine

Where to Install This Machine

Secure a suitable installation space before assembling this machine.

The place of installation must have enough space for not only this machine itself, but also for the printing operation.

Model	Width	Depth	Height	Gross weight
Tx300P-1800B	3,183 mm (125.3 in)	1,912 mm (75.3 in)	1,844 mm (72.6 in)	627 kg (1,382.3 lb)

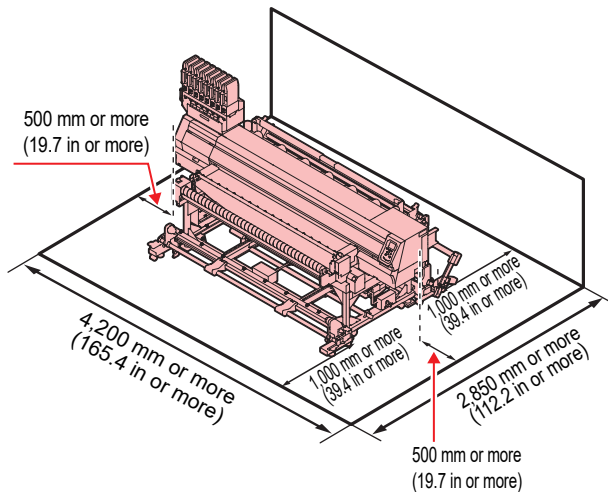

Working Environmental Temperature

Use this machine in an environment of 20 to 30°C to ensure reliable printing.

Moving This Machine

Move this machine according to the following steps when this machine needs to be moved on the same step-free floor.



- When the machine is moved to any place other than on the same step-free floor, contact your distributor or our service office. If you move it by yourself, failure or damage may occur. Be sure to request your distributor or our service office to move this machine.



- When moving this machine, take care that it does not receive a significant impact.
- After movement, get the adjuster foot down and perform each adjustment.

1

Detach the take-up unit from the printer.

2

Detach the feeding unit from the printer.

3

Raise the adjuster feet on the printer.

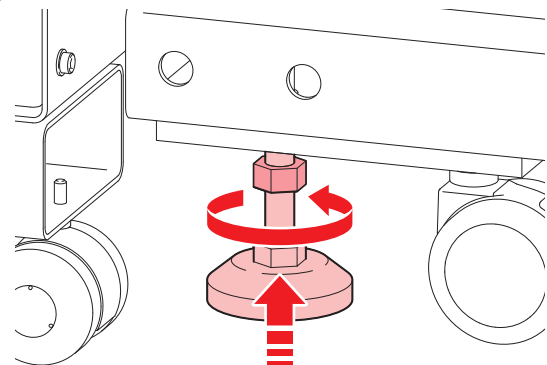

4

Move this machine as shown in the figure.

- For safety, be sure to operate it with 4 people or more.
- Do not push the cover to move this machine since the cover may be broken.

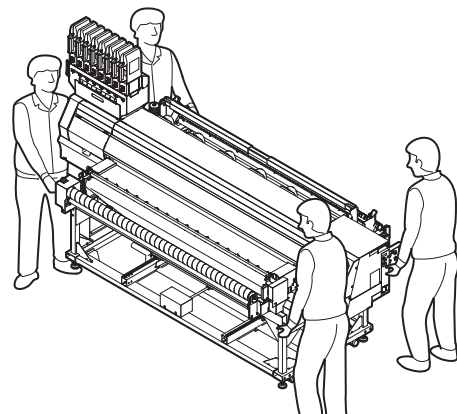

- 5** Lower the adjuster feet on the printer.

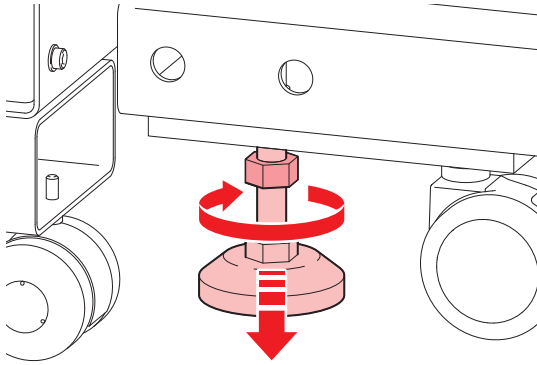

- 6** Adjust horizontal level.

- 7** Adjust meandering.

- 8** Attach the take-up unit to the printer.

- 9** Attach the feeding unit to the printer.

Names of Parts and Functions

Front Side of the Machine

Maintenance cover (upper)

Open the cover in maintenance.
Even when the power switch is off, keep all covers closed.

Ink cartridges

Each cartridge contains an ink of a particular color.

Front cover

Open the cover in setting of medias, taking of measures against jamming of medias or in maintenance inside the station.
Even when the power switch is off, keep this cover and the other covers closed.

Feeding belt

Carrying fabric.

Peeling roller

Peel the fabric from the feeding belt.

Carriage

Move the print head unit from side to side.

Operation panel

This panel has the operation keys required for operating the machine and the LCDs for displaying setting items, etc.

CleaningSolutionCartridge slot

Insert the cleaning solution cartridge.

Waste ink tank

Waste ink gathers in this tank.

Water valve

The valve for feeding cleaning water.

Stand

Supports the main body of the machine. It is provided with casters that are used to move this machine.

Belt washing unit

Cleans the feeding belt.

Roll rests

The rests on which the media is placed.

Take-up device

Automatically winds up the roll media printed.

Fabric roller

Removes ink adhering to peeling roller to prevent ink from spoiling cloth media.

Maintenance cover (lower)

Open the cover in maintenance.
Even when the power switch is off, keep all covers closed.

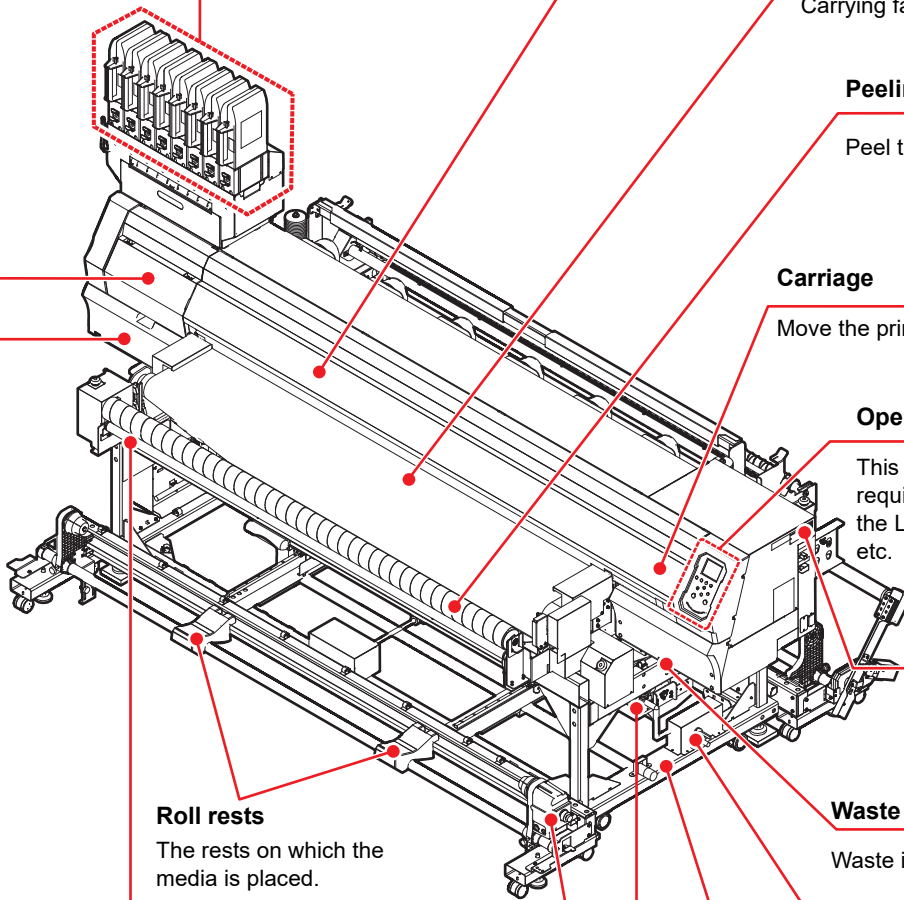

Rear Side and Right Side of the Machine

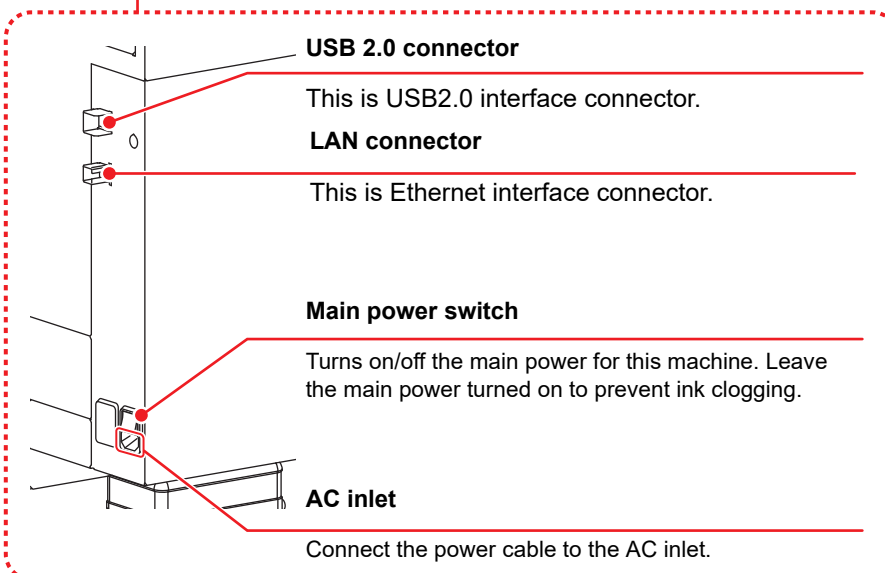
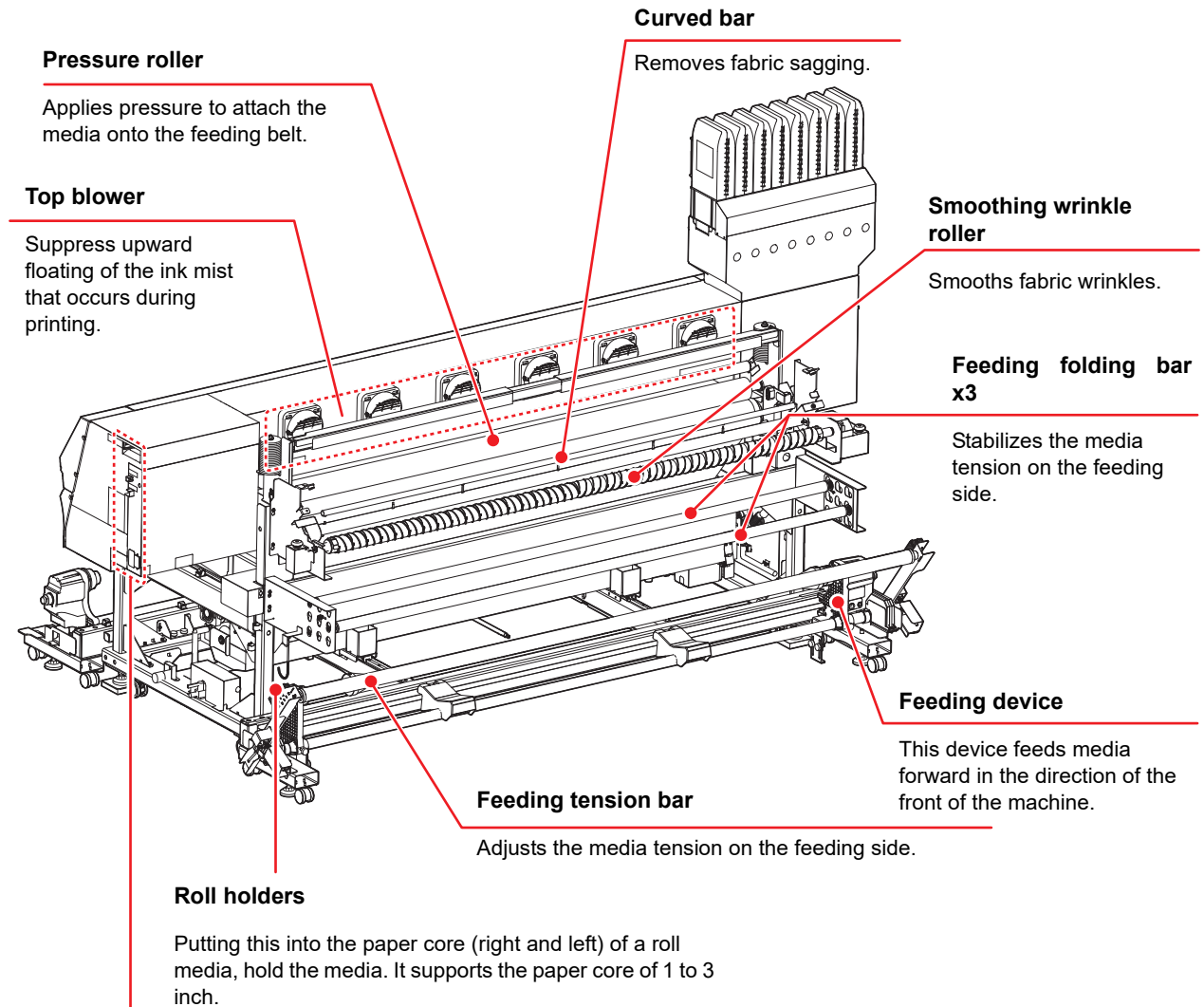

Operation Panel

Use the operation panel to make settings for printing or operate this machine.

SEL key
Changes over the functions of the function keys ([FUNC1]–[FUNC3]).

[FUNC1] / [FUNC2] / [FUNC3] key
Press this to set various functions or to do test printing. The function keys' functions are changed each time [SEL] key is pressed.

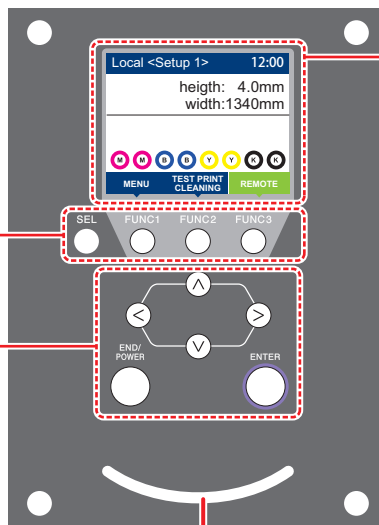

Display

- Displays the following items:
- Printer status
 - Set media width
 - Ink status *1
 - Functions assigned to [FUNC1] to [FUNC3] *2

JOG key (Left, Right, Up, Down)
Use these keys to shift the carriage or the media in [LOCAL]. Also use them to select an item of printing conditions.

[END/POWER] key
Cancels the last input value or returns the setting menu to the immediate higher level of the hierarchy. Also, press this to turn the power on or off. (Give it a long press to turn the power off.)

[ENTER] key
Registers the last input value as the setting value or goes to the immediate lower level of the hierarchy.

Status indicator lamp

Indicates the machine's status (printing, error occurred, etc).

Condition of Lamp	Condition of machine
OFF	Machine is in LOCAL mode, no print data has been received, and no errors have occurred.
Lit steady Light blue	Switched to REMOTE mode.
Flashing Light blue	Currently printing.
	In test printing: printing a pattern stored inside the machine.
Lit steady blue	Print data still remains in the machine.
Flashing red	Error has occurred.
Lit steady red	Error (SYSTEM HALT) has occurred.
Lit steady yellow	Firmware is being updated.



- The power switch under the operation panel lights in blue when the power is turned on, and off when the power switch is turned off. The ink clogging prevention function is periodically operated even when the power switch is OFF if the main power switch keeps being ON. (Auto maintenance function) P.1-5













*1: Ink Status

Status of the ink cartridge (remaining ink/error, etc.) is displayed using icons. Each icon is described below.

Icon	Contents																		
	The remaining amount of ink is displayed in 9 stages. The remaining amount decreases moving to the right. <table border="1" style="margin: 5px auto;"> <tr> <td></td> <td></td> <td></td> <td></td> <td></td> <td></td> <td></td> <td></td> <td></td> </tr> <tr> <td>ink full</td> <td>Approximately 1/8 consumed</td> <td>Approximately 1/4 consumed.</td> <td>Approximately 3/8 consumed.</td> <td>Approximately 1/2 consumed.</td> <td>Approximately 5/8 consumed.</td> <td>Approximately 3/4 consumed.</td> <td>Approximately 7/8 consumed.</td> <td>near end</td> </tr> </table>										ink full	Approximately 1/8 consumed	Approximately 1/4 consumed.	Approximately 3/8 consumed.	Approximately 1/2 consumed.	Approximately 5/8 consumed.	Approximately 3/4 consumed.	Approximately 7/8 consumed.	near end
ink full	Approximately 1/8 consumed	Approximately 1/4 consumed.	Approximately 3/8 consumed.	Approximately 1/2 consumed.	Approximately 5/8 consumed.	Approximately 3/4 consumed.	Approximately 7/8 consumed.	near end											
	Displayed at ink end (only when the 4-color ink set is used) and ink near end.																		
	Indicates that the cartridge cannot be used due to ink end or ink error (remaining ink 0, cartridge not attached, etc.).																		
	Indicates that ink has expired or that one month has passed after the expiration date. Please use quickly. Ink can no longer be used if two months have passed after the expiration date.																		

*2: Functions assigned to [FUNC1] to [FUNC3]

Contents of functions assigned to [FUNC1] to [FUNC3] are described below.

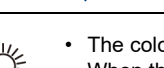
Icon	Contents
	Displays "MENU" for setting functions.
	Displays maintenance functions such as test print, cleaning, etc.
	Shifts to REMOTE from LOCAL and starts printing.
	Displays adjustment functions such as FEED COMP, DROP.POScorrect, etc.
	Executes data clear.
	Suspends printing in REMOTE and shifts to LOCAL.
	When there are multiple items on the MENU screen or other screens, it moves to the next page.
	When there are multiple items on the MENU screen or other screens, it moves to the previous page.
	Used for completing confirmation when warning message has been displayed and so on.
	Used for turning functions OFF or cancelling them, for example, when turning heater settings OFF and so on.
	Some kind of setting or function is assigned. Operate according to the description of each function.
	Switches between enable/disable when selecting multiple items, for example, when selecting target head for cleaning and so on.
	Detects and resets the media.



- The color of icons changes according to the state of the printer.
 - When the icon is green : The printer is in REMOTE mode.
 - When the icon is dark blue : The printer is in LOCAL mode.
 - When the icon is yellow : A warning has been issued.
 - When the icon is red : An error has been issued.

Carriage

The carriage is provided with the ink heads for printing, the "LED pointer" to be used for manually setting the width of the set media (☞ P.2-15).

A lever is also provided to adjust the height of Head according to the thickness of media. (☞ P.2-5)

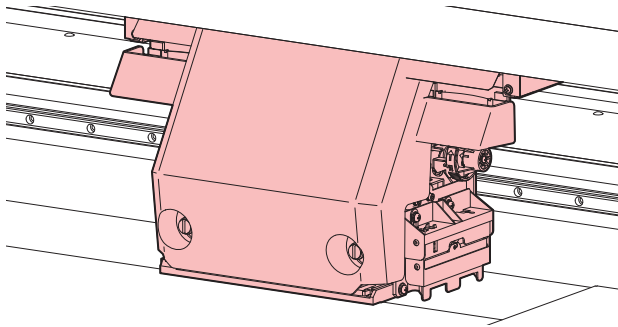

Capping station

The capping station consists of the ink caps, the wiper for cleaning the heads, etc.

The ink caps prevent the nozzles in the ink heads from drying up.

The wiper cleans the nozzles in the heads.

The wiper is consumable. If the wiper is deformed or the media is stained, replace the wiper with a new one.



- Be sure to wear the attached safety glasses in cleaning within the capping station to protect your eyes against ink. Otherwise, you may get ink in your eyes.

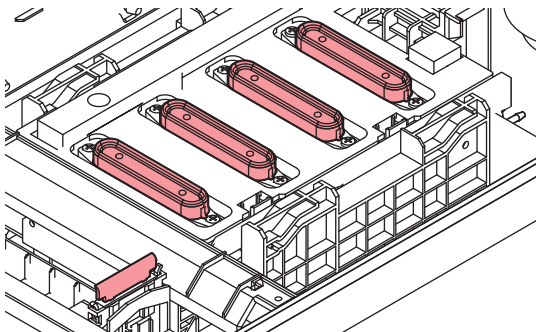

Connecting Cables

Connecting USB2.0 Interface Cable

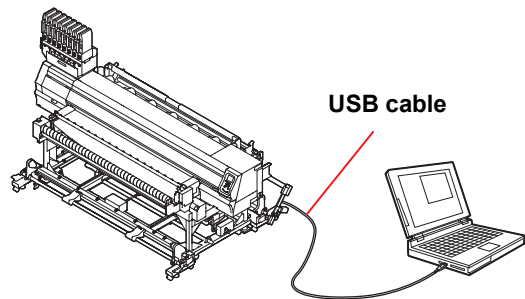

Connect the PC and this machine with the USB2.0 interface cable.



- Your RIP must be compatible with USB 2.0.
- Contact a RIP maker near your location or our office when the USB2.0 interface is not attached to the PC.

Notes on USB 2.0 Interface



- Your RIP must be compatible with USB 2.0.

● When two or more Tx300P-B machines are connected to one personal computer

When two or more Tx300P-B machines are connected to one personal computer, the personal computer may not recognize all the Tx300P-B machines normally.

Reconnect the unrecognized Tx300P-B machine to another USB port, if available, and check to see if it is recognized. If the Tx300P-B machine is not recognized by the newly connected USB port, use USB 2.0 repeater cables available on the market.

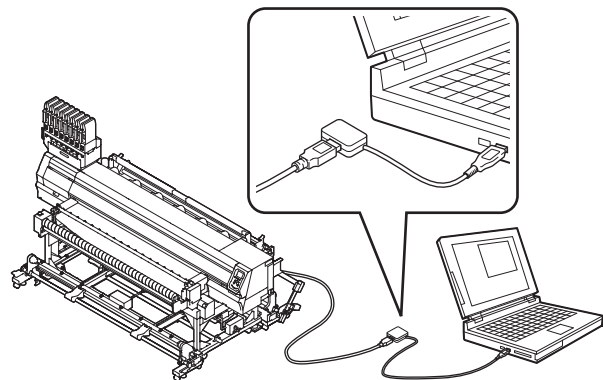

● Notes on peripheral devices in USB high speed mode

When a peripheral device (USB memory or USB HDD) to be operated in USB high speed mode is connected to the same personal computer that a Tx300P-B machine is connected to, the USB device may not be recognized.

When Tx300P-B is connected to the personal computer to which an external HDD is connected via USB, the speed of data output to Tx300P-B may drop. That can cause the head unit to stop temporarily at the right or left end during printing.

● Removing USB memory

If a USB memory module is inserted in the personal computer to which a Tx300P-B machine is connected, click “Stop” in the “Safely Remove Hardware” window by following the instructions given there first and then remove the module.

Leaving a USB memory module inserted can cause [ERROR 10 COMMAND ERROR].

Copy the data onto the hard disk before outputting it for printing.

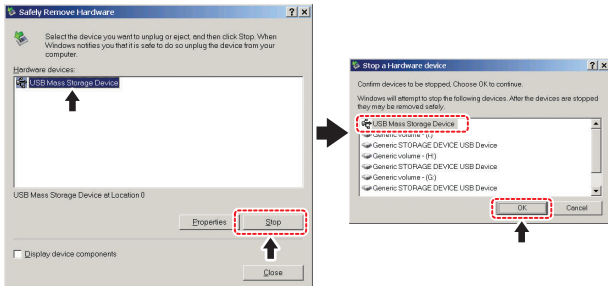

Connecting the LAN cable

When connecting LAN cable, be sure to follow the note below:

- Important!** • Surely insert LAN cable until clicking noise sounds.
- Do not plug in or unplug any cable during data transferring.

Printing Via a Network

If printing via a network, you need to configure your network with the following environment.

If you configure it with an inappropriate environment, it could cause printing to stop.

- Use LAN cables that are category 6 or higher.
- Use a switching hub and PC that support 1000BASE-T.

- Important!** • Set the PC sending the print data and the printer to the same network.
- You cannot connect via a router.

● If connecting directly to the printer

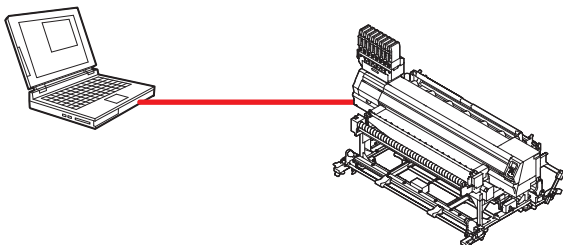

● If connecting via a switching hub

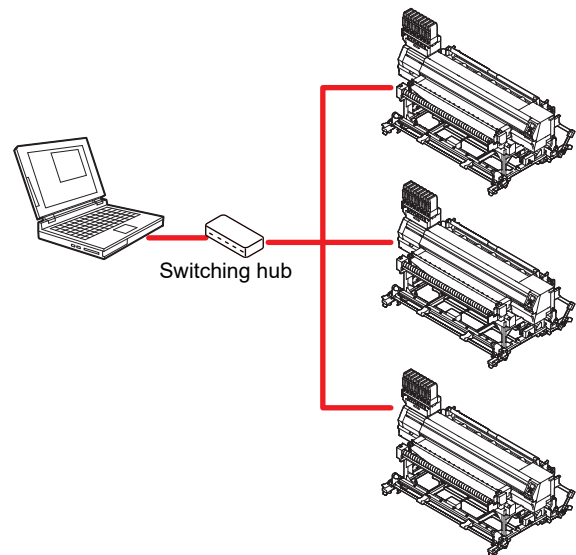

If the PC or device connected to the printer is not 1000BASE-T, you cannot perform printing. After connecting, check the following.

(1) Check the printer screen display.

- On the local screen or the media detection screen, press the [Enter] key several times to display the information screen.
- Check that “100Mbps” is displayed for the LAN status item.

- Important!** • If “100Mbps”, “10Mbps”, or “No connect” is displayed, you cannot print using the LAN.
- If “100Mbps” or “10Mbps” is displayed, you can use event mail (Chapter3 “Setting event mail function”).

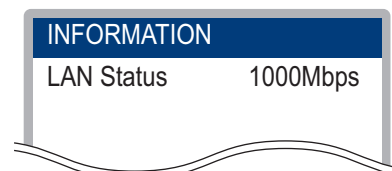

(2) Check the green light of the LAN connector.

- After turning on the machine, the lamp for the LAN connector will light up as follows.

Color	State	Condition
Green	Lighting	Connected with 1000BASE-T
	OFF	Connected without 1000BASE-T
Yellow	Lighting	Link-up
	Blinking	Receiving data
	OFF	Link-down

- Important!** • If the yellow light only lights up, or is blinking, the status is not 1000Mbps. Check the specifications of the PC, device, and cables.

Connecting the power cable

- 1 Insert the power cable into an inlet of the machine.

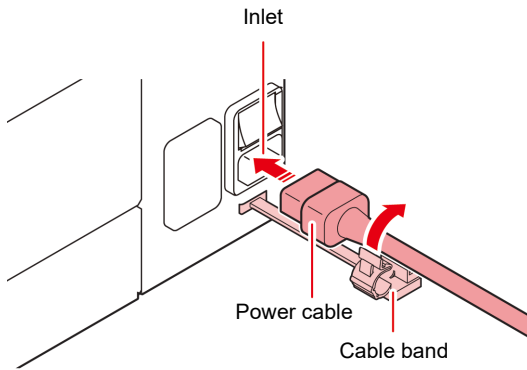

- 2 Secure a cable band.
 - Secure the cable with the cable band attached to this machine.

- 3 Insert the power plug into a plug socket.

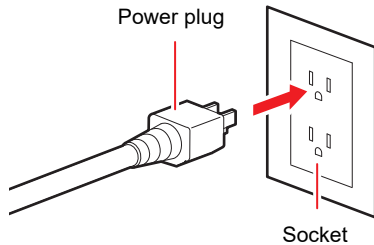

- Do not use any power cables other than the attached power cable.



- Be sure to connect the power cable to the outlet near this machine, and make sure that the power cable can be easily removed.
- Connect the power cable to the grounded outlet. Otherwise, it may result in fire or an electric shock.

Setting Ink

- 1 Take out the 2L ink pack.
 - Take out the 2L ink pack and the IC chip from a small cardboard box.

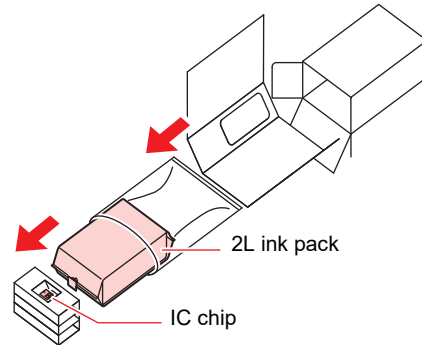

- 2 Mount the IC chip.

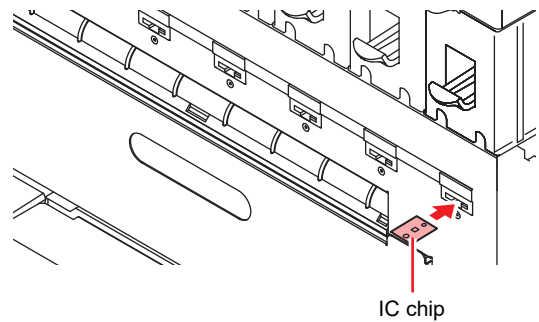

- Be careful of the IC chip direction. If it is set in the wrong direction, ink is not supplied properly.

Insert the chip facing the metal side to the left.

Do not touch the metal part while inserting. (The IC chip may be damaged by static electricity.)

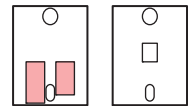

- 3 Put the 2L ink pack into the 2L eco-case.

- (1) Open the 2L eco-case as shown on the right.

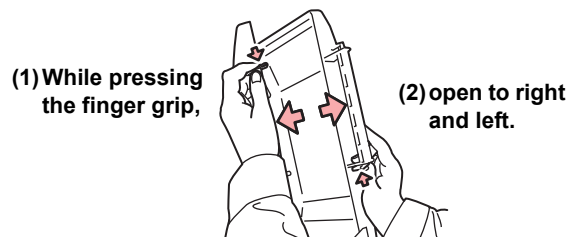

- (2) Tear off the seal on the connector of the 2L ink pack.

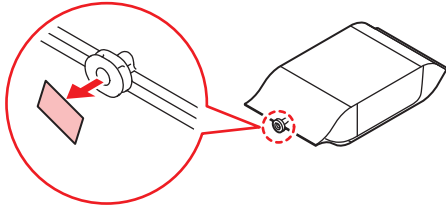

- Be careful of the IC chip direction. If it is set in the wrong direction, ink is not supplied properly.



- (3) Put the 2L ink pack facing the connector down, and close the 2L eco-case.

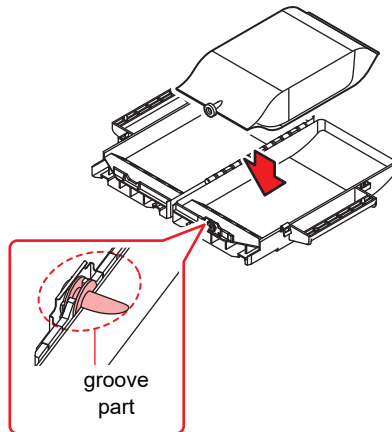

- When putting the 2L ink pack, shape the pack referring to the label in the 2L eco-case. If unshaped, you may not use up the ink.
- Before closing the 2L eco-case, make sure the connector of the ink pack is placed on the groove part of the 2L eco-case. If it is not placed on the groove, it may not supply ink.

4

Attach the 2L eco-case to the base.

- Ink is supplied to the printer connecting to the 2L eco-case.
- After 1 or 2 minutes, EMPTY lamp on the connected printer goes out.

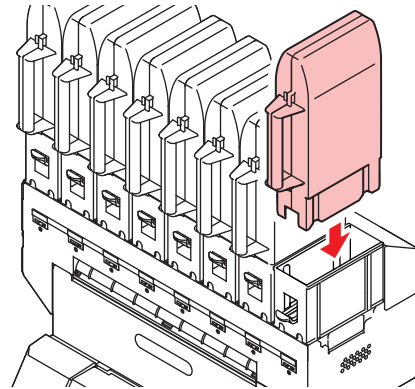

- Push the 2L eco-case all the way in. If not, it may not supply ink.

1

Replacing the 2L Ink Pack

Perform as follows when [INK END] or [INK NEAR END] is displayed on the display.



- When exchanging 2L ink pack, be sure to wear the included safety glasses and gloves. Ink may splatter and get in your eyes accidentally.



- Although approximately 10 cc of ink remains in the ink pack after use, the pack is filled so that the actual amount used is two liters.

● When [INK END] is displayed

1 Push the lever of the base down, and remove the 2L eco-case.

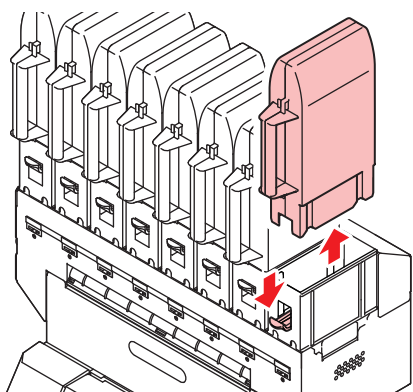

- When replacing the 2L ink pack, replace the male connector absorbent (attachment) periodically to prevent the stain in the base.
- Replace the absorbent every five to ten times of the 2L ink pack replacement.
- When replacing the absorbent, be sure to wear the included safety glasses and gloves.

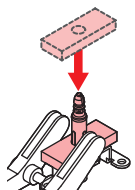

2 Remove the IC chip.

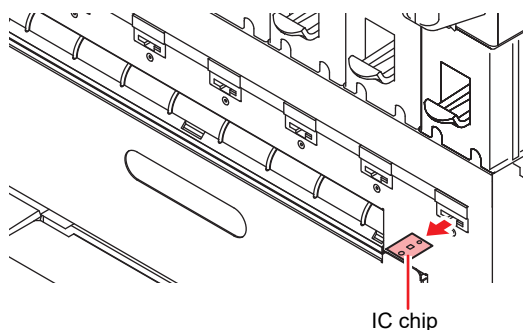

3 Open the 2L eco-case, then replace the 2L ink pack.

- Keep the IC chip removed in the step 2 with used 2L ink packs.
(Not to mix with an IC chip of a new ink pack)

4

Mount the IC chip supplied with the replacement 2L ink pack.



- Be careful not to touch the metal part of the IC chip. There is the danger of damaging IC chip because of static electricity being generated.

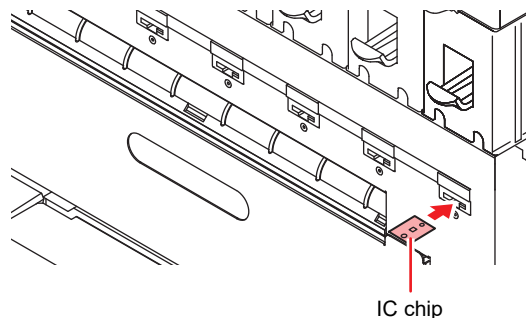

- Request an industrial waste disposal company for disposal of used ink packs.
- If removing an ink pack before it ends, follow the procedures below.
Otherwise, you cannot accurately grasp the remaining amount of ink.

- (1) Remove an ink pack from an eco-case.
- (2) Wipe ink adhering to inside of the connector part of the 2L ink pack with a cotton swab etc.

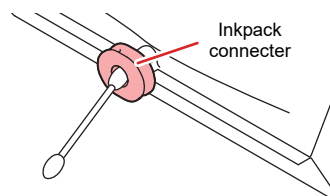

- (3) Remove the IC chip, and keep it with the ink pack.
- (4) If you use the ink pack again, set the pack, and mount the IC chip kept with the pack.

● When [INK NEAR END] is displayed

There is a little of ink left. It is recommended to replace the ink pack soon since ink may become empty in printing while printing is continuously enabled.



- During [INK NEAR END] is displayed, Auto cleaning does not operate. (P.3-10)

For Ink cartridge lamps

The condition of the ink cartridges set in the machine is confirmable with lamps located under the ink cartridges.

Ink cartridge lamps

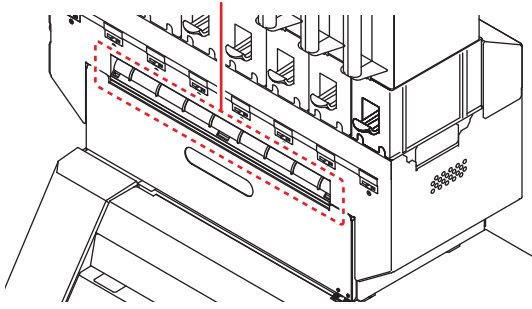

Condition of Lamp	Description
Lit to blue	No error (ink is being supplied)
OFF	No error
Lit or blinks to yellow	One of the following errors occurs. <ul style="list-style-type: none"> • Ink near-end • Expiration of a term of ink validity (one month)
Blinks to red	Expiration of a term of ink validity (two months)
Lit to red	One of the following errors occurs. <ul style="list-style-type: none"> • Ink end • No ink IC chip inserted • Other ink errors (☞ P.5-7)

About ink expiration date

The ink pack has its expiration date. When this expiration date is exceeded, a message is displayed in LOCAL and for the guidance message. (☞ P.5-4, P.5-7)

You can use the cartridge in two months after the expiration date indicated on it, however, you cannot use it when three months have passed from the expiration date. As LED will blink quickly to inform you of it, replace the ink pack.

Ex.) When the expiration date is April
 May : Usable
 June : Usable (LED lits to yellow)
 July : Unusable (LED blinks to red)

About Name

In this manual, the 2L ink pack, 2L eco-case and ink IC chip are collectively described under the name of "ink cartridge".

Caution in handling of ink packs



- Use genuine ink packs for this machine. This machine functions by recognizing the genuine ink packs. In case of troubles caused by modified ink packs or the like, it shall be out of the warranty even within the warranty period.
- If the ink pack is moved from a cold place to a warm place, leave it in the room temperature for three hours or more before using it.
- Be sure to thoroughly consume the ink in the ink pack, once it is opened, within three months. If an extended period of time has passed away after opening the cartridge tank, printing quality would be poor.
- Make sure to store ink packs in a cool and dark place.
- Store ink packs and waste ink tank in a place that is out of the reach of children.
- Request an industrial waste processor for processing of empty ink packs.
- **Precautions for new installation and replacement of new spout rubber**
 - Moisten the surface of the spout rubber with maintenance solution sufficiently before inserting. Inserting the rubber into the eco-case without moistening may damage the rubber.

Important!

•In that case, use a maintenance solution that is suitable for the ink type.

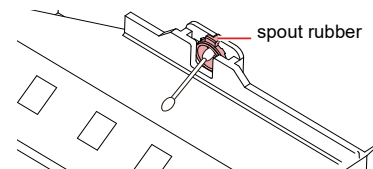
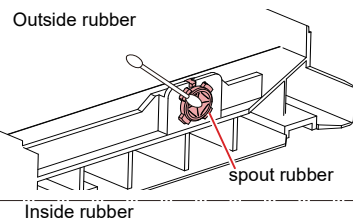

- **Precautions for using a partially used ink pack**
 - Wipe the ink off the inside of the ink pack connectors with cotton swab. Inserting the ink pack while the ink remains inside the connector part may cause ink leaking when the ink pack is used again.



•Do not insert the cotton swab too deeply. Ink may leak out of the ink pack and become unstoppable.

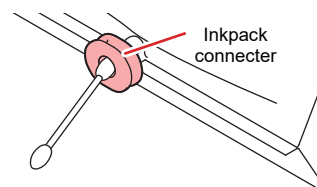



- **Precautions for setting the eco-case in the main unit**
 - Confirm that the eco-case is fully inserted. Check whether there is a gap between the MBIS Base and the eco-case. If there is a gap, insert the eco-case again.

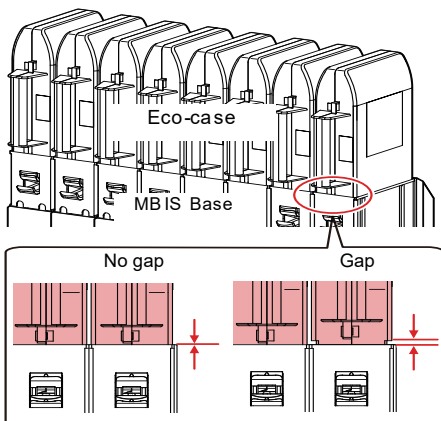

- **Method of agitating the ink pack in the eco-case**
 - When agitating the ink pack after removing. (Recommended method)
 - Wipe off the ink from the connector part of the ink pack and the inside of the spout rubber before resetting.
 - Cover the connector part of the ink pack with a paper towel (Wiping Rags, etc.) before agitating.
 - When agitating the ink pack together with the eco-case
 - Spout rubber with a paper towel (Wiping Rags, etc.) before agitating.

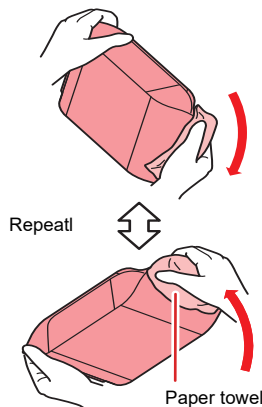

- Do not shake ink packs violently. This may result in ink leakage from the ink packs.
- Never refill the ink packs with ink. This may result in troubles. MIMAKI will not bear any responsibility for any damage caused by the use of the ink packs refilled with ink.



- Do not disassemble the ink packs.

Media

Usable media sizes and notes for handling are described.

Usable sizes of media

Model		Tx300P-1800B
Maximum width		1,900 mm (74.8 in)
Minimum width		210 mm (8.3 in)
Maximum printing width		1,880 mm (74.0 in)
Roll media	Thickness	1.0 mm or less (0.039 in or less)
	Roll outside diameter	Φ250 mm or less (Φ9.8 in or less)
	Roll weight	40 kg (88.2 lb) or less (2 to 3 inch rolls) 34 kg (75.0 lb) or less (1 to 1.5 inch rolls)
	Roll inside diameter	1 to 1.5 inch, 2 to 3 inch
	Side printed	Regardless of faces in and out
	Roll end treatment	The roll end is gently fixed to the core with weak-adhesive tape or weak glue for easy removal.

Caution in handling of medias

Pay attention to the followings for handling of medias.



- When using a media other than the following, be sure to perform test printing to confirm the plot result and then determine whether it can be used or not.



- Use media recommended by MIMAKI to ensure reliable, high-quality printing.
- When setting the fabric used, be sure to adjust the head height. Otherwise, the fabric and/or the head can be damaged.
- If preventing treatment for fray on right and left edges and tenter are thick against the fabric thickness, adjust the head height depending on the thickness of the right and left edges of the fabric.
- If using fabric with thick right and left edges, as take-up slippage may easily occur because right and left edges of the roll rise at take-up. If take-up slippage occurred, fabric tends to skew and it may cause troubles such as contact with the head nozzle surface.
- Do not use a fabric with high expansion and contraction due to ink adhesion or resilient fabric. If such a fabric is used, it may cause the trouble of contact with the nozzle surface or the misaligned printing.
- When using a fabric with curling, be sure to remove the curling before using. Strong curling may effect on the quality of printing or may hit the head nozzle surface and may cause discharging defect.
- Store fabric in a bag. Wiping off dust, waste paper and flocks accumulated on a fabric will adversely affect the fabric due to static electricity.
- When you use fabric media that will easily generate static for printing, use the attached neutralization fabric. In addition, raise the humidity of the usage environment by using a humidifier etc.

Limited media

With the following media, correction from the plotter is difficult.

When using any of the following media, perform test printing to determine whether it can be used or not.

- High stretch fabric (Stretch materials, vertically extendable knit, etc.)
- Materials which become largely extendable when getting wet by printing.
- Materials with large width variations.
- Materials which present partial wrinkles or slacks when being spread on a flat surface or materials which are totally curved.
- Materials with large take-up shift at the ends of media when rolled.
- Roll media with a paper tube whose strength is insufficient and which bends when attached to a feeding unit.

Important!

- Even when using media other than described above, be sure to print by optional test data. After checking the printing result, judge whether it can be used or not.

Fabric conditions which enable to print

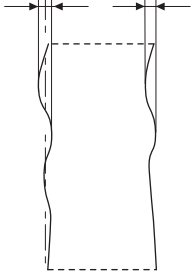
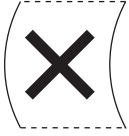
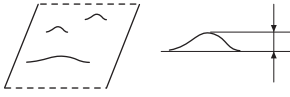
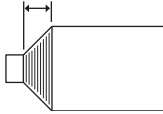
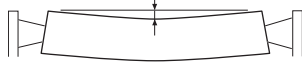
Items	Condition	Remarks
Width variation	less than $\pm 5\text{mm}$ / one side edge	
Curve when expanded	One-direction curve not allowed	
Slack height when expanded on a flat surface	2mm or less	
Displacement of roll edge	$\pm 15\text{mm}$, Cloth (width of 500mm and less) is $\pm 2\text{mm}$.	
Inner diameter of roll	1 to 1.5-inches, 2 to 3-inches	
Fabric core strength	Roll bend of 5mm or less when set.	
Fixation with fabric core	Fix with the tape three point or more or weak adhesion.	
Roll outer diameter	$\phi 250\text{ mm}$ or less	
Roll weight	1 to 1.5-inch, 34kg or less 2 to 3-inch, 40kg or less	
Print side	Not specified	
Fabric wrinkle	Not allowed	

Menu mode

This machine has 4 modes. Each menu mode is described below.

NOT-READY mode

This is the mode in which the media has not been detected yet.

LOCAL mode

Local mode is the mode for the drawing preparation state.

All the keys are effective.

The machine can receive data from the computer. However, it does not perform printing.

Screen display in Local mode

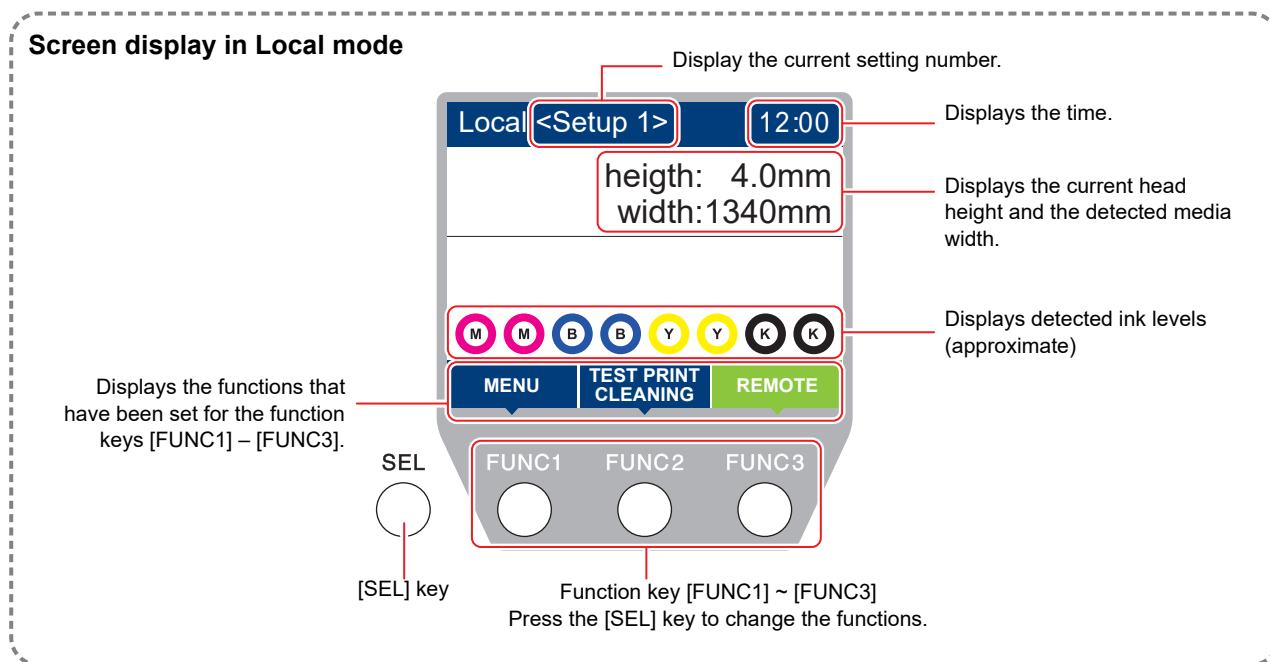

This mode permits the following operations:

- Pressing the JOG keys to set up a drawing origin and drawing area.
- Pressing the [ENTER] key to check the remaining amount of ink, the description of the cartridge error, the model name, the firmware version, and so on.

MENU mode

To set MENU mode, press the [FUNC1] key when this machine is in LOCAL mode.

In this mode, each function can be set.

REMOTE mode

This machine prints the data it receives.

Chapter 2

Basic Operations



This chapter

describes procedures and setting methods for ink and media preparation, and printing.

Workflow	2-2	Removing the smoother roller and replacing frames	2-23
Turning the Power ON/OFF	2-3	Test Printing	2-24
Turning the Power ON	2-3	Test Printing	2-24
Turning the Power OFF	2-3	Set the media feeding	2-26
Setting a Media	2-4	Flow of media feeding correction	2-26
Setting Feeding and Take-up unit	2-4	Head Cleaning	2-27
Adjusting the Head Height	2-5	About head cleaning	2-27
Printing Width	2-6	Perform head cleaning depending on the test printing result	2-27
Mounting the fabric roller	2-6	Setting of Media Correction	2-27
Using the tension bar to set the roll media ..	2-7	Setting of Media Correction	2-27
Setting roll media without using tension bar	2-12	If the Positions of Dots Shift... ..	2-28
Using the peeling to set the media	2-14	Printing Data	2-28
Setting media without using peeling	2-14	Starting a Printing Operation	2-28
Feeding/ Take-up device	2-17	Stopping a Printing Operation	2-29
Changing the printing origin	2-20	Deleting Received Data (Data Clear)	2-29
Pressure roller weight adjustment	2-20	Behavior after printing has been completed	2-29
Peeling sensor positioning adjustment	2-21	To reduce waste of media	2-29
Eradicating Media Sagging with the Curved Bar	2-22		

Workflow

1 Turning the Power ON/OFF

Referring to “Turning the Power ON/OFF” (☞ P.2-3).

2 Setting a Media

Referring to “Setting a Media” (☞ P.2-4).

3 Test Printing

Referring to “Test Printing” (☞ P.2-24).

4 Head Cleaning

Referring to “Head Cleaning” (☞ P.2-27).

5 Printing Data

Referring to “Printing Data” (☞ P.2-28).

Turning the Power ON/OFF

Turning the Power ON

This machine is provided with the following two power switches:

Main power switch:

It is located on the side of this machine. Keep this switch ON all the time.

[END/POWER] key:

Normally, use this key to turn the power ON/OFF. The nozzle clogging prevention function periodically operates even with the [END/POWER] key turned OFF when the main power switch is turned ON.

1 Turn the main power switch ON.

- Set the main power switch located on the side of this machine to the "I" side.

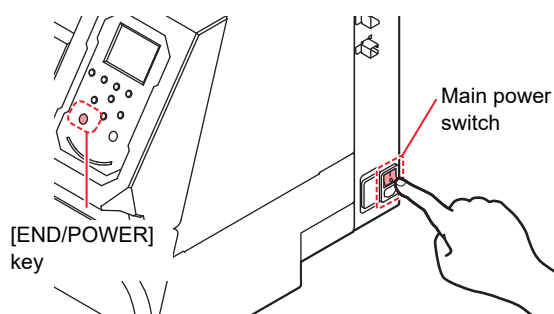

- The firmware version is displayed when the power is turned ON, and then the machine performs its initial operation.

2 Turn the power on, by pressing the [END/POWER] key.

- The machine enters LOCAL.

3 Turn ON the power of the connected PC.

Important!

- Turn the power ON after the front cover and maintenance cover are closed.
- The head nozzle may result in nozzle clogging if the main power switch is left OFF for a long time.

Turning the Power OFF

When having ended the operation of the machine, turn the power OFF by pressing the power switch located on the front side.

Check the following items when turning the power OFF.

- If the machine is receiving data from the PC or if there is any data that has not been output yet
- If the head has returned to the capping station
- If any error has occurred
(☞ P.5-8 "Error messages")

1 Turn OFF the power of the connected PC.

2 Turn the power off, by giving the [END/POWER] key a long press.

- Do not turn OFF the main power switch located on the side of the machine.
- To use this machine again, press the [END/POWER] key.

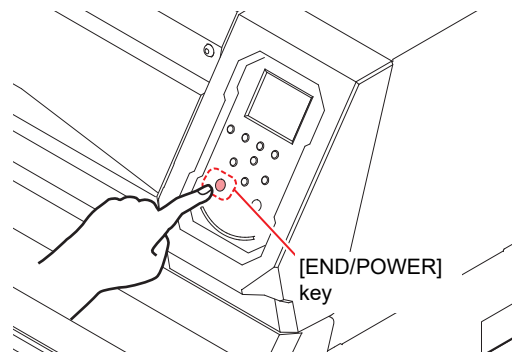

Cautions about Turning the Power OFF

● Do not turn the main power switch OFF.

When the main power switch is ON, the power periodically turns ON and the nozzle clogging prevention function (flushing function) operates. When the main power switch has been turned OFF, the auto maintenance functions, such as flushing, do not operate, and this may cause nozzle clogging.

● Keep the front cover and the maintenance cover closed.

If the cover is opened, the auto maintenance function such as the flushing function does not work.

● Raise the pressure roller on the rear of the printer.

The pressure roller will get stuck on the belt if left lowered, which will result in defective conveyance.

● Turn the power OFF after having checked the position of the head.

If the power is turned OFF in a state where the head has not returned to the capping station, the ink head dries, which may cause nozzle clogging. In this case, turn the power ON again and check that the head has returned to the capping station, and then turn the power OFF.

● Do not turn the power OFF during printing.

The head may not return to the capping station.

● After having turned the power switch OFF by pressing [END/POWER] key, turn the main power switch OFF.

When turning the main power switch off for moving the machine or for solving the error or the like, press the [END/POWER] key a long time on the front of the machine, check the display is turned off on the operation panel, and then turn the main power switch off.

Setting a Media

This machine can be used with a roll media and leaf media.

For usable medias, refer to P.1-14 "Usable sizes of media".





- Take care not to drop the media on your foot when setting the media. It may cause an injury due to the media.
- When setting a roll media, work by two or more people. Otherwise, you may hurt your back by the weight of the roll media.
- Adjust the head height prior to setting the media. If the head height is adjusted after the media is set, this may cause a media jamming, deterioration of the print quality or head damage.

Setting Feeding and Take-up unit



For the "Feeding and Take-up unit" settings, set the following items:

- Use feeding unit and take-up unit/ Do not use feeding unit or take-up unit.
- Use/Do not use feeding tension bar.
- Use or not use of the peeling.
- Operation when the ON/OFF switch for feeding/ take-up unit is pressed.

In this machine, by selecting how to use the feeding tension bar in the feeding/take-up unit setting, you can print by any of the following two methods.

Feeding tension bar	How to set the media
Use	Set the media refer to  P.2-7.
Do not use	Set the media refer to  P.2-13.

In addition, by selecting the manner to use the peeling function, you can print by any of the following two methods.

Peeling	How to set the media
Use	Set the media refer to  P.2-14.
Do not use	Set the media refer to  P.2-14.

1 Press **FUNC1 (MENU)**   (twice)  **ENTER** in LOCAL.

- MACHINE SETUP MENU will be displayed.

2 Press   to select "FEEDING/TAKE-UP UNIT", and press the **ENTER** key.

3 Press the **ENTER** key.

- "FEEDING UNIT" will be selected.

4 Press   to select a set value, and press the **ENTER** key.

- Set Value: ON/ OFF
- When you select [OFF], proceed to the Step 7.

5 Press  , and press the **ENTER** key.

- "FEEDING TENSION BAR" will be selected.

6 Press   to select a set value, and press the **ENTER** key.

- Set Value: ON/ OFF

7 Press  , and press the **ENTER** key.

- "TAKE-UP UNIT" will be selected.

8 Press   to select a set value, and press the **ENTER** key.

- Set Value: ON/ OFF

9 Press  , and press the **ENTER** key.

- "PEELING UNIT" will be selected.

10 Press   to select a set value, and press the **ENTER** key.

- Set Value: ON/ OFF

11 Press  , and press the **ENTER** key.

- "Feeding/ Take-up SW" will be selected.

12 Press   to select a set value, and press the **ENTER** key.

- Set Value: Continuance/ Temporary

Continuance:

Switching ON / OFF the winding operation when pressing the switch each time. (Take-up unit in operation does not stop until press again ON / OFF switch.)

Temporary:

Do the winding operation only while holding down the switch. (When release the switch, winding operation is stopped.)

Important!

- If you are using the direct-connection unit, the winding operation will be carried out with the "TEMPORARY" setting even if you select "CONTINUANCE".

13 Press the **END/POWER** key several times to end the setting.

Important!

- Set up the feeding tension bar on the feeding/take-up unit before setting up the media. The tension bar cannot be set after the width of the media has been set.

- You can change the ON/OFF settings of Feeding/ Take-up unit after detecting the media width.

When turning OFF from ON

Feeding/take-up unit does not operate.

When turning ON from OFF

If torque limiter is attached, only take-up operation without using tension bar is performed.

If direct-connection unit is attached, take-up operation is not performed.

- If you want to change the feeding/ take-up method while setting media, remove the set media and carry out the operations from step 1 again.

Adjusting the Head Height

Set the head gap (height from the media to the nozzle plane of the heads).

When the carriage is to move above the belt for printing or maintenance, it moves while keeping the head gap at the preset value.

The upper limit of the head gap varies with media thickness.

Available setting values: [2.0 mm to 7.0 mm] (in units of 0.05 mm)

1 Press **FUNC1** (MENU) → **▼** (twice) → **ENTER** key in LOCAL.

- MACHINE SETUP MENU will be displayed.

2 Press **▲** **▼** to select "HEAD HEIGHT", and press the **ENTER** key.

- Move the carriage to the belt.

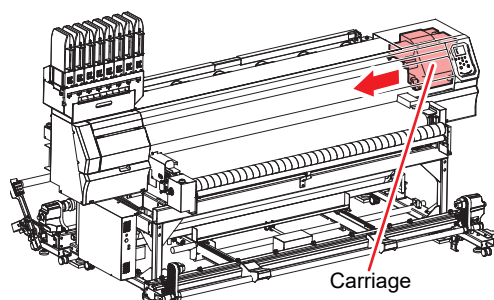

3 Loosen the height-adjusting screw in front, and press the **ENTER** key.

- Loosen the screws, rotating each by one turn of a standard screwdriver.

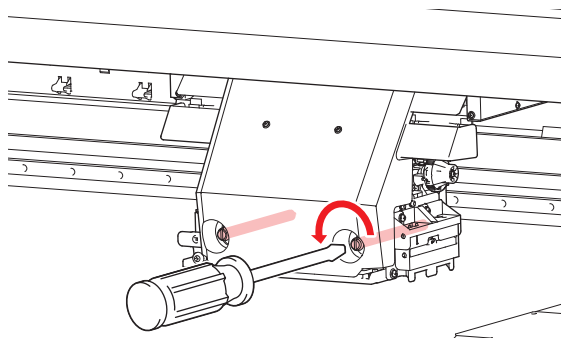

4 Adjust the height-adjusting handle according to the media.

- Rotate **②** while pressing **①**.
- Look at the display and adjust to an appropriate value.

Height-adjusting handle

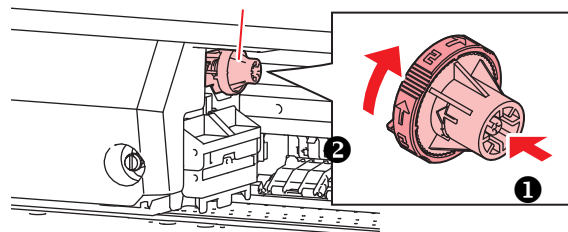

5 Fix the carriage.

- Fasten the screw securely.

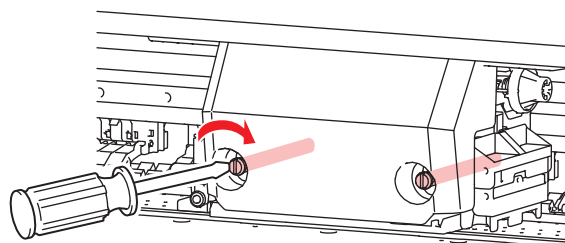

6 Press the **ENTER** key.

- The carriage automatically returns to the station.

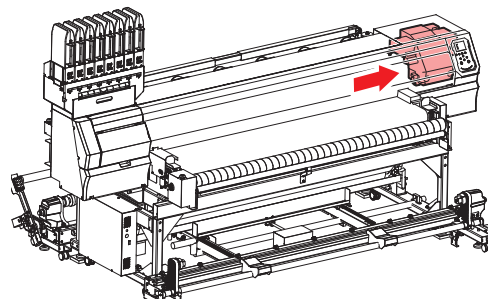

7 Press the **END/POWER** key several times to end the setting.

Printing Width

Printing Width: 1,880mm

Overprint: 1,900mm

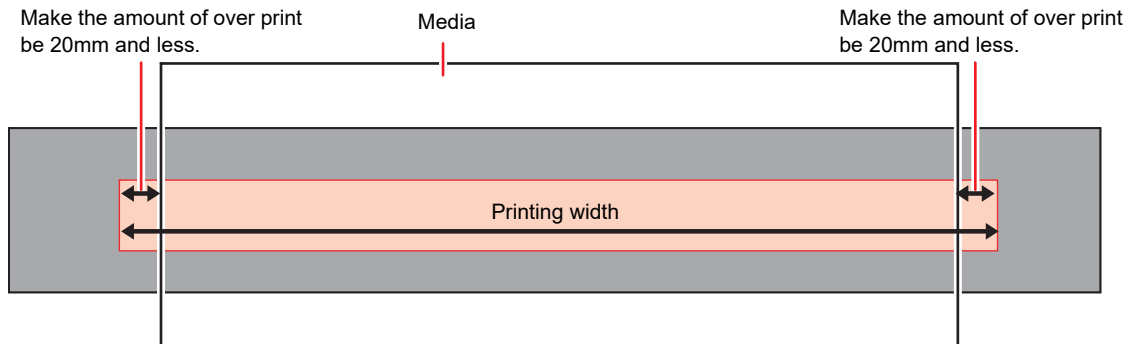

Mounting the fabric roller

When printing on a loose fabric, the ink remained on the back of the fabric may attach to the peeling roller, and the ink may stain the fabric media.

With the fabric roller mounted, the stain of the fabric media can be avoided by the roller removing the attached ink to the peeling roller.

Important!

- Fabric is not wrapped around the fabric roller before shipping. Prepare the well-absorbed fabric with the following size.
- Material: Cotton sheeting, cotton broadcloth or the like
- Size: 195cm x 70cm

1

Remove the fabric roller.

- The fabric rollers are located beneath the peeling roller on the front of the unit, and up against the belt on the rear of the unit.

Front

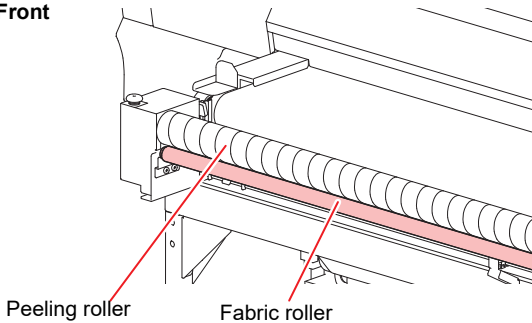

Rear

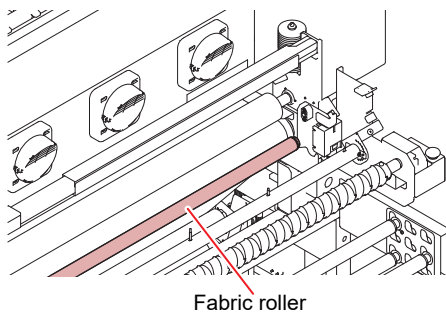

2

Wrap a fabric around the fabric roller.

- As shown on the bellow, fit a fabric with the roller.

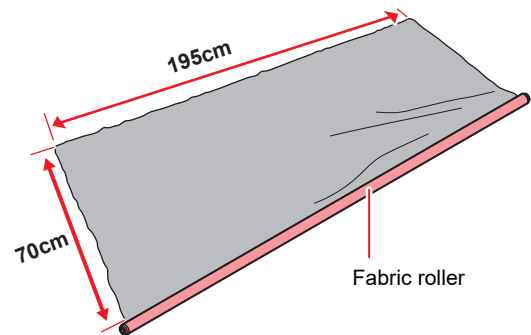

- (1) Secure the fabric and the roller with an adhesive tape.

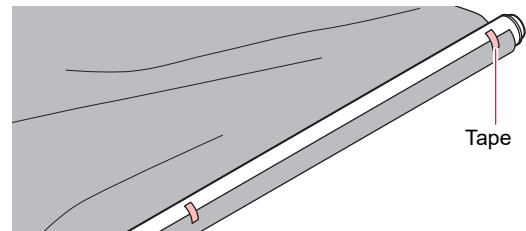

- (2) Wrap the fabric around the roller, and secure with an adhesive tape.

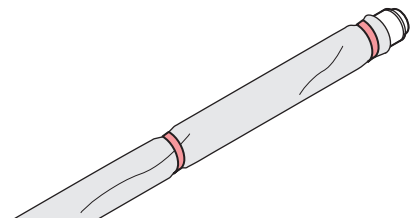

3 Mount the fabric roller with the fabric wrapped.

- Attach the fabric roller in the slot below the bracket.
 - Fit the shaft holder into the slot on both sides of the fabric roller.
- Adjust the bearing position on both ends of the fabric roller.
Loosen the screw of the bearing so that the fabric roller contacts the peeling roller.

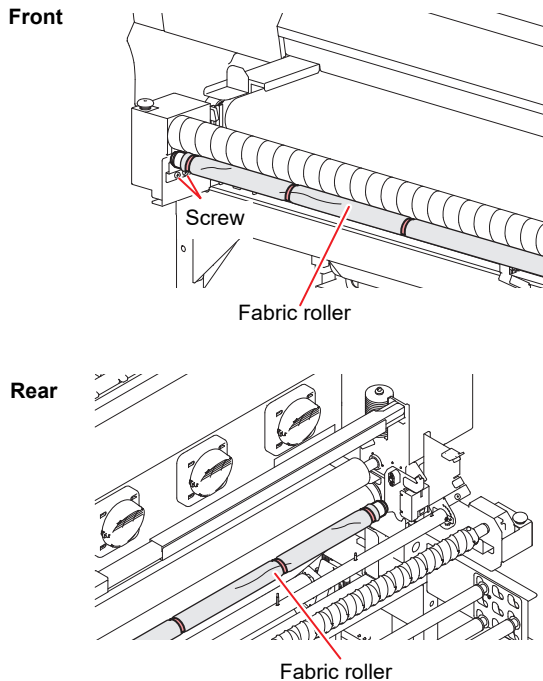

4 Turn the peeling roller manually, and check it turns smoothly.

- If the peeling roller does not turn smoothly, check the mounted position of the fabric roller.

Using the tension bar to set the roll media

The route for setting the fabric media is as shown in the following diagram.

Prior to setting the media, if you understand the routing of the media, you can perform the setting of the media smoothly.

Important!

- Check to make sure that the area that comes into contact with the media route is not stained.
- Before setting media by using tension bar, check that direct-connection unit is attached to feeding device. If torque limiter is attached, replace it with direct-connection unit by referring to P.2-12.

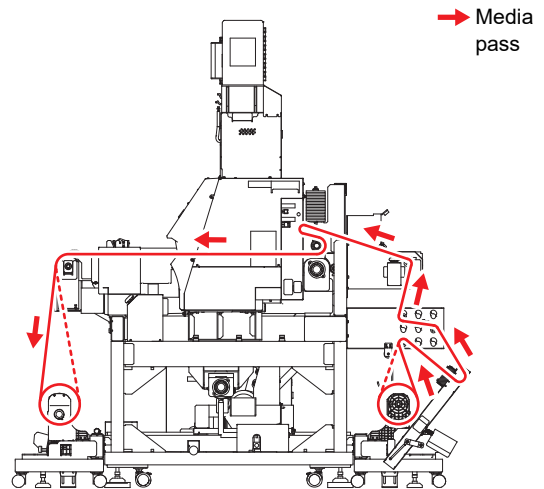

1 Close the front cover, and press the **FUNC2 (MEDIA)** key.

- The screen for "FEEDING TENSION-BAR" is displayed.

2 Select how to use tension bar according to the media setting method.

- In this case, select "ON".
(DC= direct-connection unit, TL= torque limiter
-- = unit OFF)
- Press [**▲**]/[**▼**] to select "ON" and press the [ENTER] key.

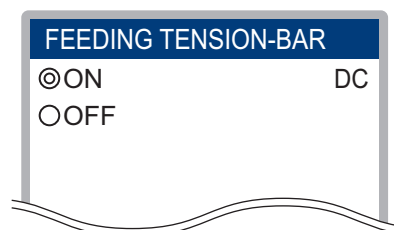

Important!

- This page is not indicated when the pre-setting of "FEEDING UNIT" is "OFF".

3 Fix feeding tension bar into its locked positions.

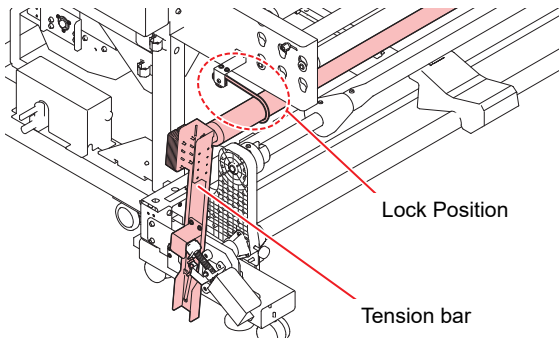

4 Attach folding bar according to the media to be set.

- To stabilize the tension on the feeding side, attach folding bar in an appropriate position to suit the media to be set.
- The position in the figure below is our recommended attachment position. Even when folding bar is attached in this position, if the media becomes loose or has vertical creases, adjust the tension to suit the media you use by referring to P.2-12.

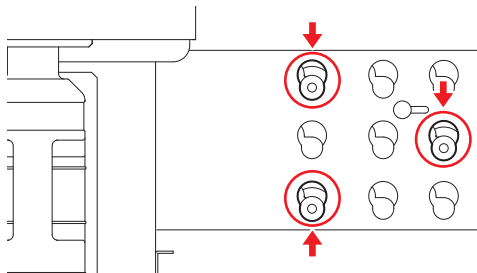

- (1) Loosen the pinch screws on the outside (left and right) of the folding bar mounting plate.
 - The folding bar press becomes movable freely.
- (2) While holding the loosened pinch screws, move the folding bar press towards you.
 - Move until it hits the stopper.

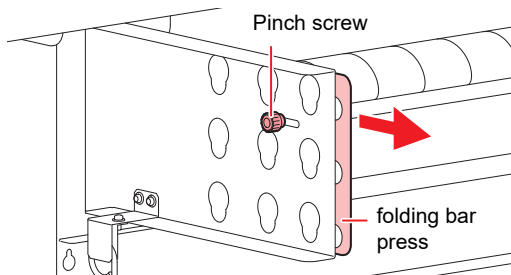

- (3) Insert and move folding bar downward.
 - Mount folding bar into the lower part of the potbelly-type hole.
 - Check the mounted position of folding bar. If inserted in a wrong position, folding bar cannot be fixed.

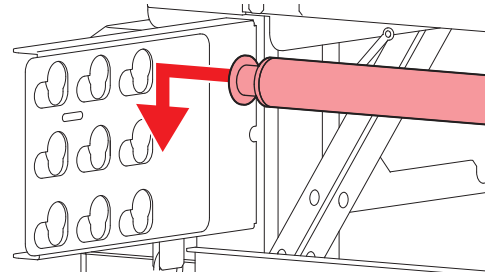

- (4) Move the folding bar press toward the machine and fix it.
 - Do the same for both the left and right folding bar mounting boards.

5 Put the roll bar into the media.

- Tighten the screws to attach the roll holder of a size that matches the paper pipe.

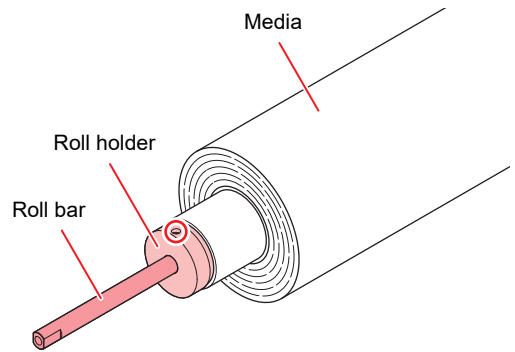

Important!

- Put the roll holder all the way seated in. If putting is insufficient, the paper pipe may be collapsed.
- There are 2 types of roll holder. Use the suitable one to meet the media paper pipe to use. (See the below figure)

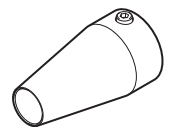

Roll holder S (for 1~1.5-inch)

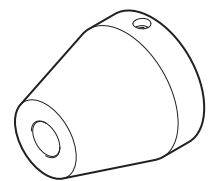

Roll holder L (for 2~3-inch)

6 Set the bar holder at the lock position.

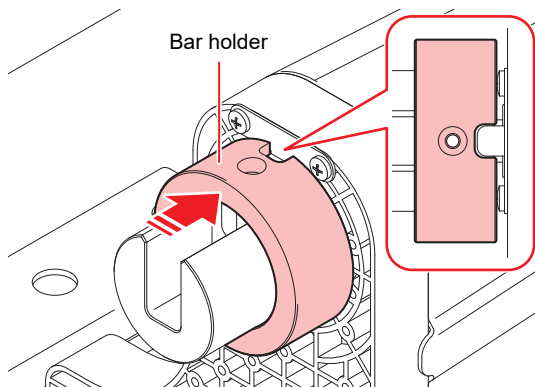

- Important!** • Put the bar holder all the way seated and check if it does not rotate.

7 Set the media to the bar holder.

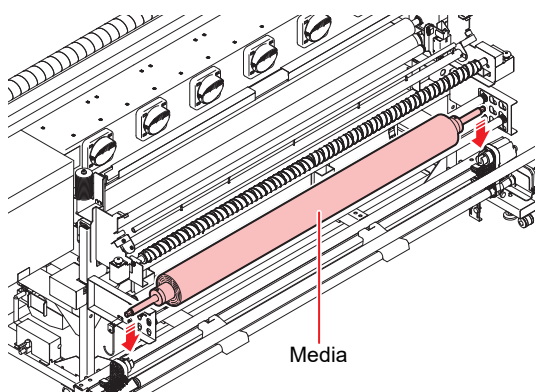

- Important!** • When setting the roll media, be careful not to drop the media on your feet. A heavy media may cause injury.
• When setting the slip sheet, make sure to work with 2 or more persons. Otherwise you may damage a waist with its heaviness.

8 Sliding the bar holder, tighten the screw.

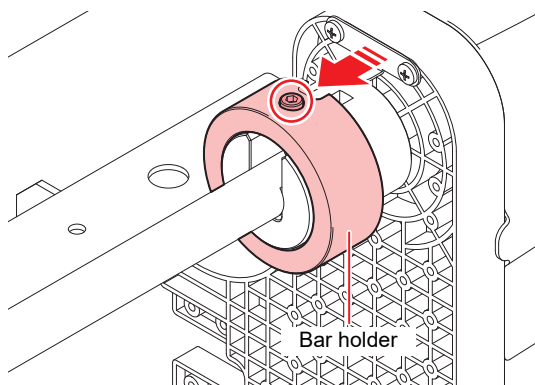

9 Rotating the media by hand, check that the rotation is possible without problems.

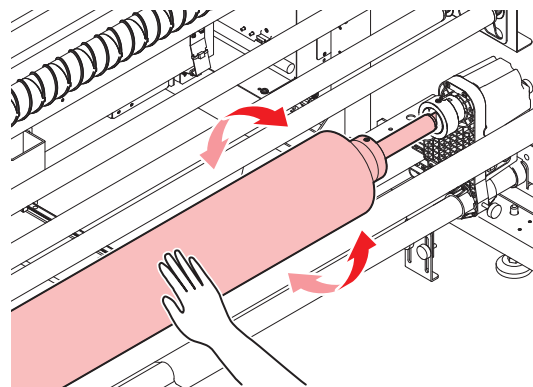

10 Lower feeding tension bar.

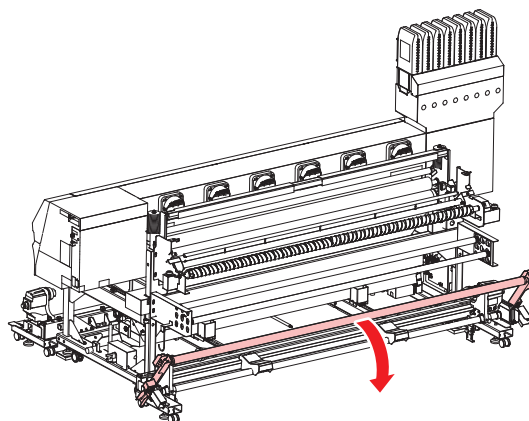

11 Set a media in the machine.

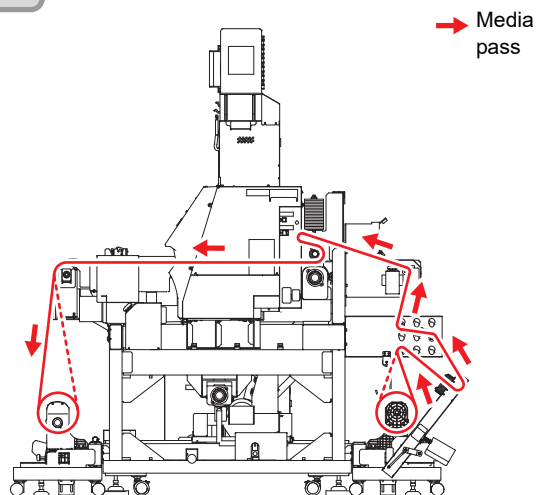

(1) Set the media in place while considering the media route.

- Feed the media through while using the tension bar and folding bar to make sure an appropriate level of tension is applied to the media.

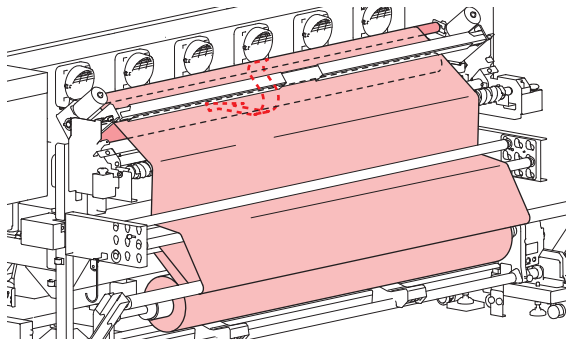

- Pass the media over the smoother roller and the curved bar and under the pressure roller's handle.

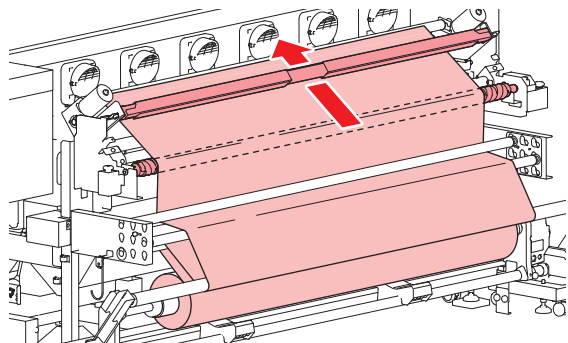

- (2)** Move the handle's lock sliders (left and right) to the center holding by hand and lower the pressure roller slowly.
- The media will be supported.



- As the pressure roller is heavy, please be careful.

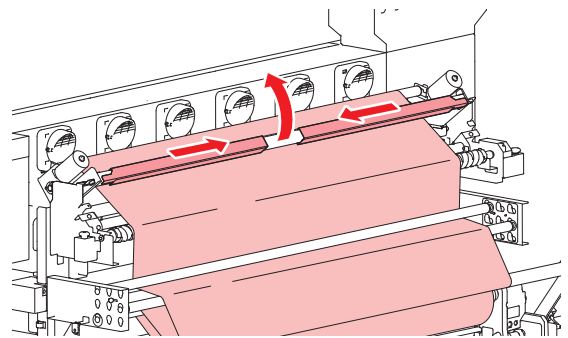

- When not using the smoother roller, refer to P.2-23. When not using the curved bar, refer to P.2-22.

12 Press the **ENTER** key.

- Move the feeding tension bar, and adjustments will be carried out when the media is detected on the feeding side.
- After completing the media detection at the feeding side, the detection of the media diameter is done consecutively.

13 Select ON/OFF of the peeling function.

- If the setting of the machine for the "TAKE-UP UNIT" is "OFF", this setting is not indicated.
- Press [▲][▼] keys to select ON/OFF and press the [ENTER] key.



- P.2-14 "Using the peeling to set the media"
- P.2-14 "Setting media without using peeling"

14 Press either of the JOG key (▼) when a message stating "Set the media in the take-up unit" is displayed on the screen.

- The feeding belt will move and the media will be fed to the front of the unit.
- Rotate the peeling roller manually to feed the media.

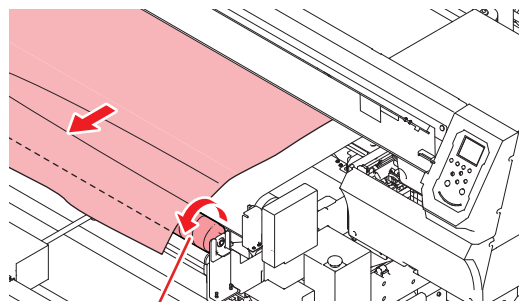

Peeling roller

15 Stop the media from being fed with the use of the JOG key when it reaches the take-up device.



- The JOG key can back-feed the media in increments of 300mm, although there is a risk of the media becoming wrinkled, folded or soiled, etc. with belt washing water. It is therefore better to avoid using the back-feed if possible.
- If this is unavoidable and back-feeding is performed, make sure the media on the take-up side is suitably loose and then operate the keys, etc., while taking up the media on the feeding side and paying close attention to the condition of the media.
- Note that we cannot accept responsibility for any damages caused by printer malfunctions, media damage or deteriorated printing quality, etc., if back-feeding is performed.

16 Set an empty paper core in the take-up device and fix the take-up legs in place on the floor.

- Fix the take-up legs onto the floor after setting the paper core in place.

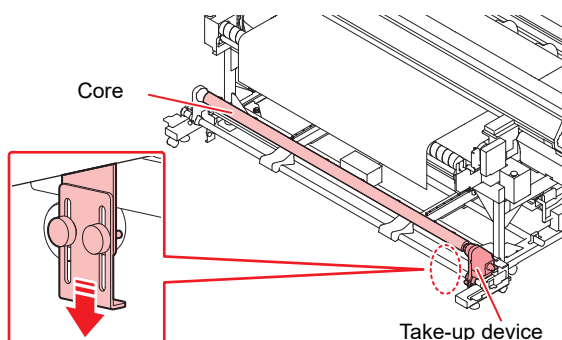

17 Fix the media in place in the take-up device.

- (1) Fix the center of the media with adhesive tape.
 - If necessary, feed the media with the JOG key.
- (2) Fix the media in place on the left and right-hand sides in the same way.
 - Pull the roll media so that it is even on both left and right sides, check to make sure that there is no sagging or wrinkles, and then fix it in place with adhesive tape.

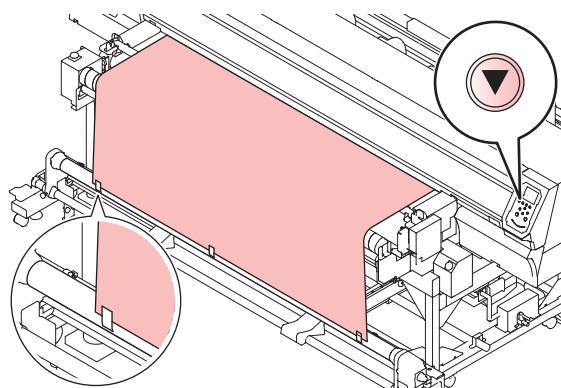

Important!

- Fix the media in place with tape in five locations when setting wide media. The more places that are fixed, the more even the media will become.
- In the event of the position of the set fabric and paper core becoming misaligned, loosen the screws on the roll holders and adjust the paper core until it is in the correct position.
- Lower your eyes until the roll becomes visible on the feeding side and check to make sure that the left side and right side of the fabric is not misaligned with the left and right sides of the roll on the feeding side.

18 With switches of the take-up device, roll up the media about once.

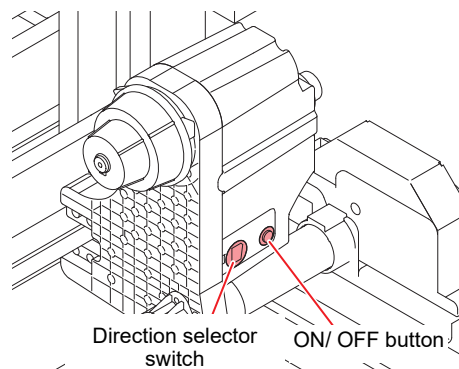

- (1) Set the take-up direction using the direction selector switch on the left, turn the ON/OFF button on the right to ON, and then take up the media.
- (2) When the media stretched tight, turn the right ON/OFF button to OFF to stop.
 - Roll the media around the paper core one time or more.
 - If the amount of media pulled out in advance is not sufficient for rolling the media around the paper one time or more, press [▼] again to feed the media and roll the media around using take-up device.

19 Press the **ENTER** key.

Important!

- When the media has been set in place, print random data to confirm that the media tension is applicable. The tension of the set media is not applicable if white or black lines appear in the printed image. Amend the position of the folding bar and adjust the weight of the feeder/take-up tension bar, and then check to make sure they are in the correct position.

How to adjust the folding bar

To perform printing on media with appropriate tension, it is necessary to adjust the mount position of the folding bar and the number of bars.

● If the tension of the media is low

Increase the winding angle.

The tension applied to the media becomes higher.

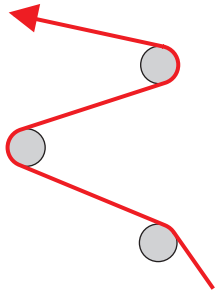

● If the tension of the media is high

Decrease the winding angle.

The tension applied to the media becomes lower.

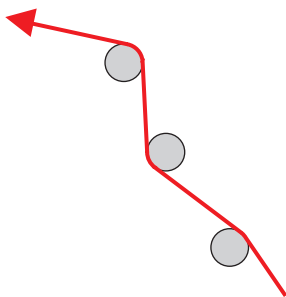

When using the media which is hard to expand and contract



- When using the media which is hard to expand and contract, it is recommended not to use the smoother roller. Set the media after removing the smoother roller. (☞ P.2-23)
It is possible to set the media in a route avoiding the smoother roller.

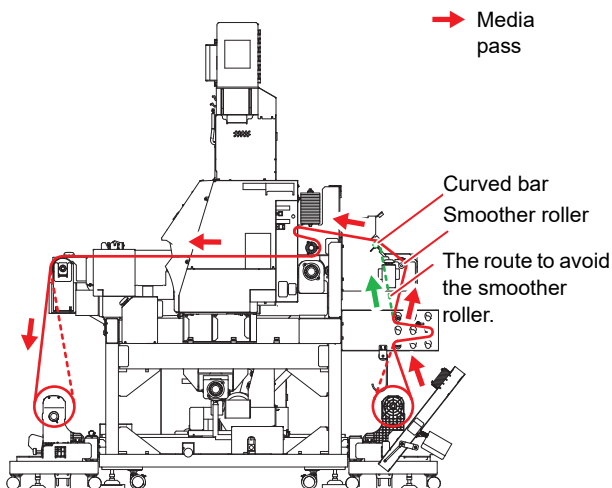

Setting roll media without using tension bar

When setting media, read the following notes carefully.



- To set roll media without using tension bar, replace direct-connection unit attached to feeding device with torque limiter that comes with the product.
- To print continuously without using tension bar, limit the media length to approximately 10 m. If you want to continuously print more than 10 m, use tension bar to set media.

Replacing the direct-connection unit

To wind the media without using tension bar, you must replace direct-connection unit with torque limiter.

1 Remove the direct-connection unit.

- Remove the thumbscrew, and then remove the direct-connection unit.

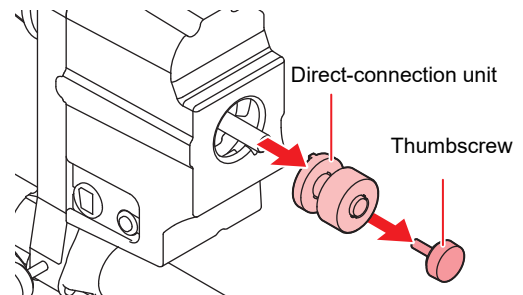

2 Attach the Torque limiter.

- (1) Insert so that the projection of the Torque limiter match the groove of the feeding/ take-up device.

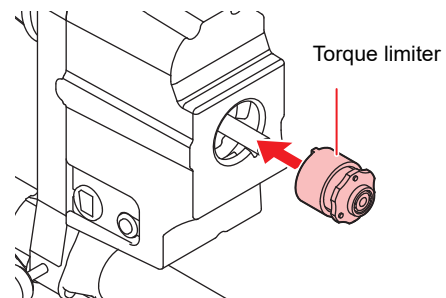

- (2) As shown in the illustration, attach it so that the tip of the shaft of the feeding/ take-up device matches the surface of the Torque limiter.



- As shown in the figure, attach it so that the tip of the shaft of the take-up device matches the surface of the torque limiter. If the tip of the shaft and the surface of the torque limiter does not match, the take-up of the media will not run well.

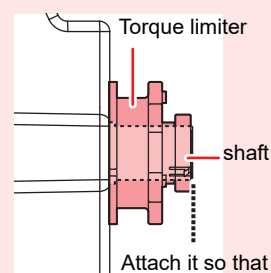

Attach it so that matches the surface.

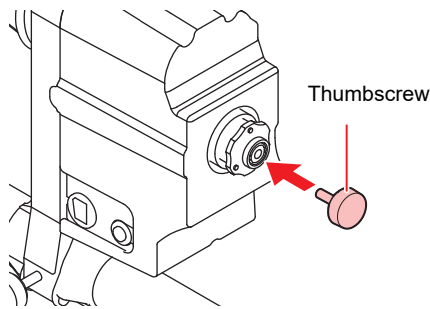
(3) Use the thumb screw to fix the Torque limiter

- Refer to the above when replacing the torque limiter with direct-connection unit.
- Insert so that the projection of the motor direct-connection unit match the groove of the feeding/take-up device when attaching the motor direct-connection unit.

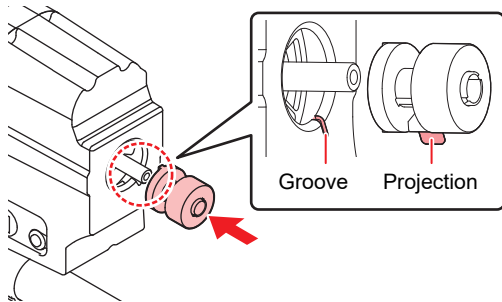

Setting roll media without using tension bar

The figure below shows an example of routing when setting cloth media without using tension bar. Prior to setting the media, if you understand the routing of the media, you can perform the setting of the media smoothly.

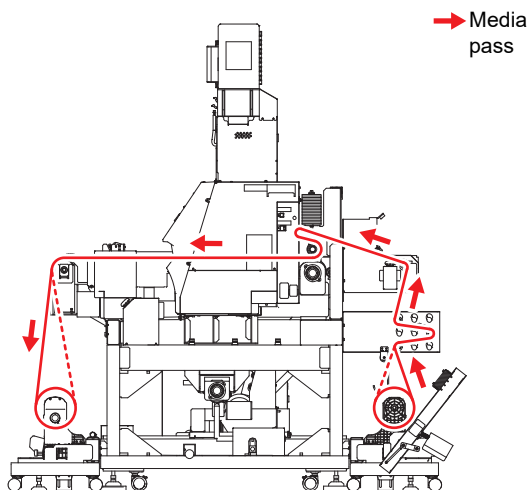

- To set roll media without using tension bar, adjust the media tension by using folding bar and torque limiter. (P.2-12, P.2-17)

1

Close the front cover, and press the **FUNC2** (MEDIA) key.

- The screen for "FEEDING TENSION-BAR" is displayed.

2

Select how to use tension bar according to the media setting method.

- In this case, select "OFF".
(DC= direct-connection unit, TL= torque limiter
-- = unit OFF)
- Press [**▲**][**▼**] to select "OFF" and press the [ENTER] key.

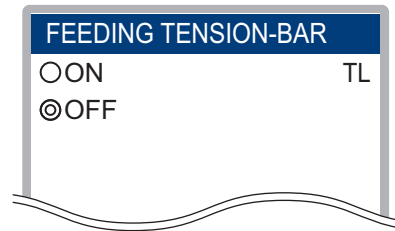

- This page is not indicated when the pre-setting of "FEEDING UNIT" is "OFF".

3

Set media on the feeding side.

- Perform the operations from steps 3 to 9 described in P.2-7 "Using the tension bar to set the roll media".

4

Feed the media to the take-up side and prepare an empty paper core in take-up device.

- Perform the operations from steps 11 to 16 described in P.2-7 "Using the tension bar to set the roll media".

5

Fix the media to the paper core.

- Perform the operations from steps 17 to 19 described in P.2-7 "Using the tension bar to set the roll media".

Set the media edge guide

1

After setting the media, move the right/left media edge guides and push them slightly against the media edges.

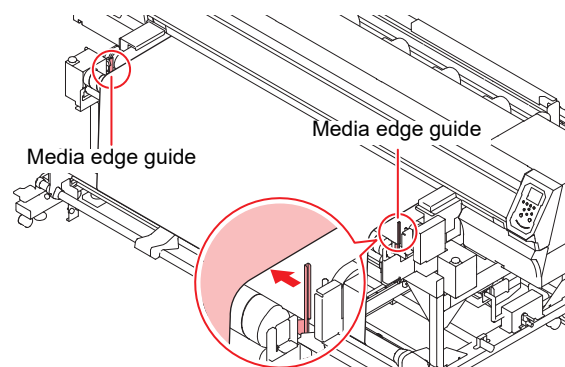

- Set the media with its edges standing by 5-10 mm.
- Be careful that the guide may contact the belt if tightening the hand screw of the media edge guide too much.

Using the peeling to set the media

Important!

- In case of using the take-up unit with the peeling function, please confirm that the take-up device has the direct-connection unit.
If there is the torque limiter, refer to the following for replacing with the direct-connection unit.
(☞ P.2-14 “Replacing the direct-connection unit”)
- If shut out the peeling sensor during a work of setting the media, it may happen that an error is displayed or the take-up device start working.
- The feeding error may be caused by using a media sticking to the rubber tape well. In that case, use with the rubber tape removed.

Set up the media to the take-up unit

1 Push the **FUNC2** (MEDIA) key and set up the media to the feeding unit.

- Details, please refer to follows.
(☞ P.2-7 “Using the tension bar to set the roll media” or ☞ P.2-13 “Setting roll media without using tension bar”)

2 Turn ON the peeling function.

- If the setting of the machine for the “TAKE-UP UNIT” is “OFF”, this setting is not indicated.
- Press **[▲][▼]** keys to select “ON” and press the **[ENTER]** key.



3 Fix the media in place in the take-up device.

- Details, please refer to the step 12~17 in P.2-7 “Using the tension bar to set the roll media”.

Setting media without using peeling

Important!

- If media sticking is strong, or when the paper core on the take-up side deflects due to the weight of the media, there is a possibility that winding by the torque limiter may not be possible. Therefore, it is recommended to wind up by the motor directly connected unit using the peeling function.
- When using the take-up unit instead of the peeling function, replace the direct-connection unit attached on the take-up device with the torque limiter.
- The feeding error may be caused by using a media sticking to the rubber tape well. In that case, use with the rubber tape removed.

Replacing the direct-connection unit

When take up the media without using the peeling function, it is necessary to replace with the torque limiter instead of the direct-connection unit.

1 Remove the direct-connection unit.

- Remove the thumbscrew, and then remove the direct-connection unit.

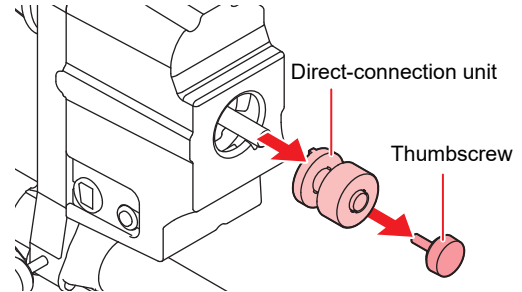

2 Attach the Torque limiter.

- (1) Insert so that the projection of the Torque limiter match the groove of the feeding/ take-up device.

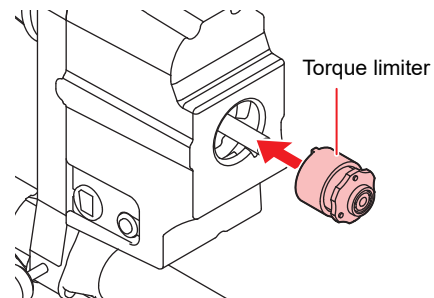

- (2) As shown in the illustration, attach it so that the tip of the shaft of the feeding/ take-up device matches the surface of the Torque limiter.

Important!

- As shown in the figure, attach it so that the tip of the shaft of the take-up device matches the surface of the torque limiter. If the tip of the shaft and the surface of the torque limiter does not match, the take-up of the media will not run well.

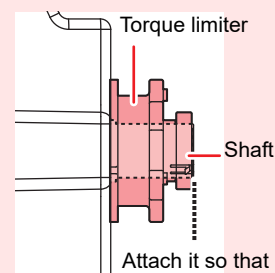

(3) Use the thumb screw to fix the Torque limiter

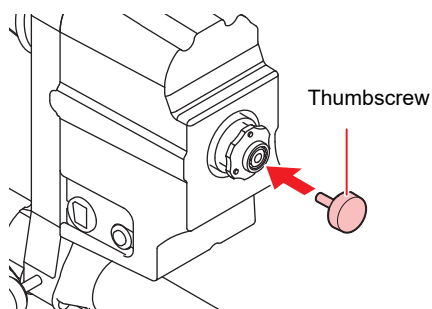

- Refer to the above when replacing the torque limiter with direct-connection unit.
- Insert so that the projection of the motor direct-connection unit match the groove of the feeding/take-up device when attaching the motor direct-connection unit.

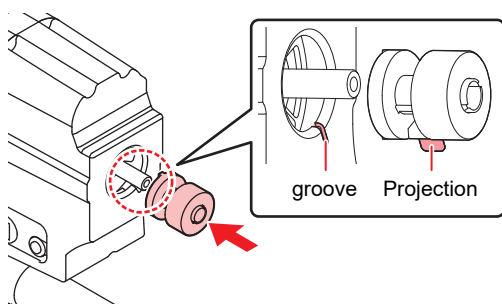

Set up the media to the take-up unit

1 Push the **[FUNC2] (MEDIA)** key and set up the media to the feeding unit.

- Details, please refer to follows.
 ☞ P.2-7 "Using the tension bar to set the roll media" or ☞ P.2-13 "Setting roll media without using tension bar"

2 Turn OFF the peeling function.

- If the setting of the machine for the "TAKE-UP UNIT" is "OFF", this setting is not indicated.
- Press **[▲][▼]** keys to select "OFF" and press the **[ENTER]** key.



3 Fix the media in place in the take-up device.

- Details, please refer to the step 12~17 in P.2-7 "Using the tension bar to set the roll media".

Entering the media remaining amount

When **[MEDIA RESIDUAL]** of the machine setup is "ON" (☞ P.3-16), the screen for entering media remaining amount is displayed after detecting the media width.

1 Display the screen for entering media remaining amount.

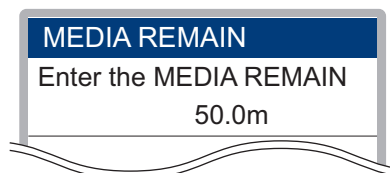

2 Press **[▲][▼]** to enter the media remaining amount.

3 Press the **[ENTER]** key.

About the media residual print

When **[MEDIA RESIDUAL]** of the machine setup is "ON" (☞ P.3-16), You can print a list of print the current date and media remaining.

1 In Local, Press **[▲][▼][◀][▶]**.

- It enters into the origin setting mode.

2 Press the **[FUNC3]** key.

- Appear the confirmation screen of media remaining print.

3 Press the **[ENTER]** key.

- Media residual print starts.

Setting of the media width setting

Set the media width in the following method.

1 Display the "MEDIA DETECT" screen.

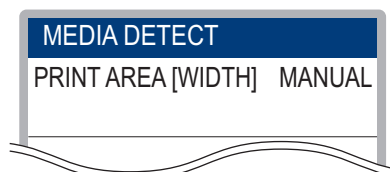

2 Select the print area setting method.

- When setting the print area, use either "Manual" to set the right and left edge of the media using the jog key, or "Media width input mode" to set the right edge of the media after inputting media width.
- When "Manual" is selected, proceed to Step 3. And when "Media width entering mode" is selected, proceed to below.

(1) Press **[▲][▼]**, and enter the media width.

(2) Press the [ENTER] key, and perform after step3.

3 Press **[←] [→]** to set a light point of the LED pointer to the right edge position of the media.

- Press **[←] [→]** to move the carriage, and align the built-in LED pointer with the right edge of the media.

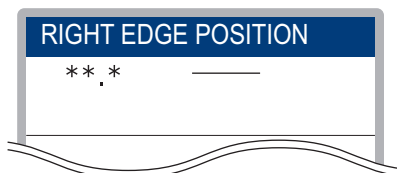

4 Press the **[ENTER]** key.

- Next, the screen to enter the left edge position of the media is displayed. When "Media width entering mode" is selected on step 2, this setting is end without display this screen.

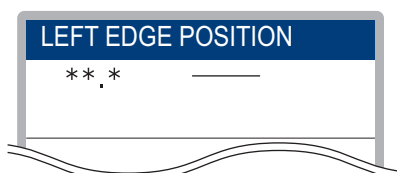

5 Press **[←] [→]** to set a light point of the LED pointer to the left edge position of the media.

- In the same manner as in step 3, align the light of the LED pointer to the left edge of the media.

6 Press the **[ENTER]** key.

Important!

- If you do not perform over printing, be careful not to set the position beyond the media range, as it may cause printing or outside the media.

Entering media thickness

If the thickness input setting in [MEDIA DETECT] in machine setup is turned "ON" (☞ P.3-16), set the media thickness as follows:

1 Display the screen for entering the media thickness.



2 Press **[↑] [↓]** to enter media thickness.

3 Press the **[ENTER]** key.

Resetting the Media

Reset the media if the PRINT AREA [WIDTH] setting has been changed or the media is to be replaced.

1 Press the **[SEL]** key in the local mode, and then press **[FUNC2]** (MEDIA).

2 Press the **[▲]** or **[▼]** key to select the method of resetting the media, and then press **[ENTER]**.

- Media resetting can be selected from two methods.
 - Width Only
Sets only PRINT AREA [WIDTH].
 - All
Resets all media sensor information.

3 Press the **[ENTER]** key.

Feeding/ Take-up device

With the switch of the feeding/ take-up device, select the take-up direction of the media or others.

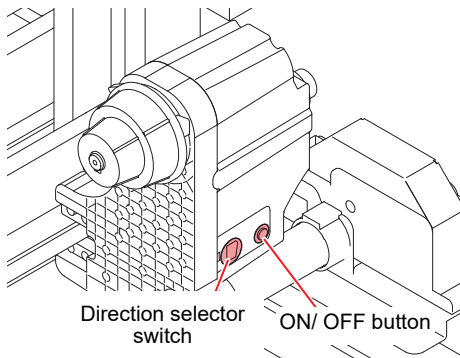

Feeding unit	Direction selector switch	UP (REVERSE)	<ul style="list-style-type: none"> To feed face-in media by using tension bar. Applying tension on face-out media using small take-up unit.
		DOWN (FORWARD)	<ul style="list-style-type: none"> To take up face-out media by using tension bar. Applying tension on face-in media using small take-up unit.
	ON/OFF button	Turns the winding motion on/off. (When you press the button and operate the feeding device, the device keeps taking up the media until you press the button again. *1)	

*1. You can also change the setting so that the feeding operation only lasts while the ON/OFF button is being pressed. For details, refer to "Setting Feeding and Take-up unit" (P.2-4) in machine setups.

Take-up unit	Direction selector switch	UP (REVERSE)	The take-up device winds the media with the printed side facing in.
		DOWN (FORWARD)	The take-up device winds the media with the printed side facing out.
	ON/OFF button	Turns the winding motion on/off. (When you press the button and operate the take-up device, the device keeps taking up the media until you press the button again. *1)	

*1. You can also change the setting so that the taking-up operation only lasts while the ON/OFF button is being pressed. For details, refer to "Setting Feeding and Take-up unit" (P.2-4) in machine setups.

Setting the torque limiter

The feeding and take-up device direct-connection unit is also included when you purchase the product. If you do not use the feeding tension bar and the peeling function, replace the direct-connection unit with the torque limiter. The feeding and take-up torque can be adjusted with the torque limiter.

(The torque limiter is set to "Medium" at delivery.)

If the tension is too strong to use a thin sheet of media, lower the take-up torque with the torque limiter.

Clockwise turn:

Increases torque (a heavy and thicker media such as tarpaulin or the like)

Counterclockwise turn:

Decreases torque (For light media)

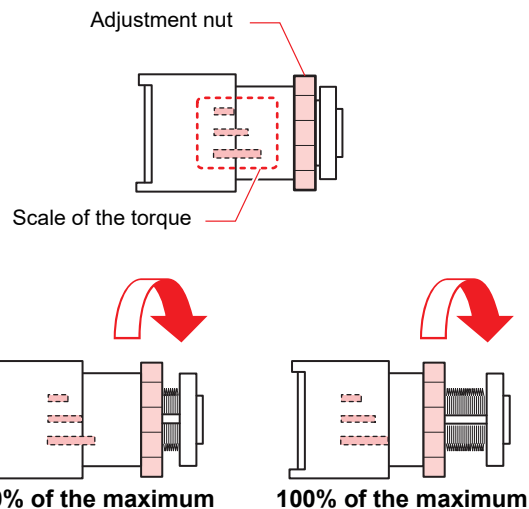

Important!

- **When the torque limiter is adjusted too weak;** The media can not be taken up firmly.
- **When the torque limiter is adjusted too strong;** The slack may occur depending on the media and cause influence on the image quality.

- When using the tension bar, adjust the torque limiter at about 75 to 100% of the maximum torque.

When adjusting the torque limiter, use the torque adjustment handle supplied.

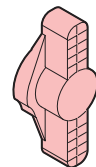

- There are the following two methods for taking up the media on printer:

- (1) Only use the take-up device to take up the media
- (2) Use the peeling function to take up the media.

Tension Bar Weight Adjustment

There are many different types of media available, including media made with different materials, such as natural materials and synthetic materials, and media made with different production methods, such as woven and knitted. The stretch and shrink characteristics also differ in accordance with the way in which they are preprocessed, even when made with the same materials and methods. It is therefore necessary to adjust the weight of the tension in order to print with a tension that matches up with the media.

● Yardstick for Weight Adjustment

Check to make sure that a suitable level of tension for the media in use is being applied by referring to the conditions listed below. If unsuitable tension is being applied, it is necessary to adjust the number of counterweights in use.

Weight	Media Surface	Condition During Printing
Not Enough	Sagging appears in localized areas, and the surface of the media is not flat.	
Suitable	The surface is maintained.	
Too Much	The surface of the media is wrinkled.	The tension bar cannot be raised, or the paper core slips.

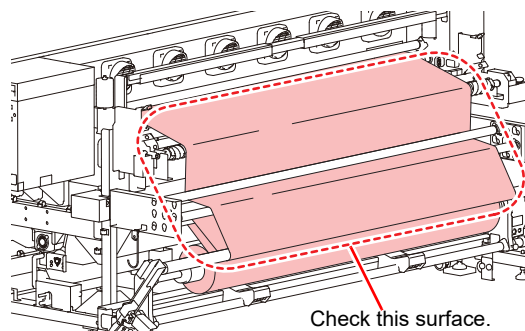

About counter weight

- Counter weight is not attached to this machine when you purchase the product.
- The maximum weight for weights to be attached to one place is 700 g
- Check the tension of the media and attach an appropriate number of weights.
- By changing where to attach counter weight is not attached to this machine when you purchase the product. The maximum weight for weights to be attached to one place is 700 g (large: 100 g x 2 sheets, small: 50 g x 10 sheets), you can change the weight of tension bar.
- If the same amount of weight is put on the upper side or the lower side, counter weight is heavier when that amount of weight is put on the upper side.
- Counter weight is put at four points in total: two points on the feeding side (left and right) and two points on the take-up side (left and right). Put weights in such a way that the weight at each of the four points becomes the same. If it is not the same, tension bar may bend and print quality may become worse.
- Not to lose the unused counter weight, put it in the storage box.

About weight adjustment spring

- A green spring is attached when you purchase the product. You can change the weight of tension bar by changing the spring type or removing the spring.
- The weight adjustment spring can be adjusted at two points on the feeding side (right and left). For the strength of the weight adjustment spring, set the same value at each of the two points. If the strength is not the same, the tension bar may bend and print quality may become worse.
- Wear gloves to replace or remove weight adjustment spring. The shaft to which the spring is attached is coated with grease. Do not wipe off grease coating the shaft.

How to adjust tension bar

- (1) Adjust the weight of tension bar by changing weight adjustment spring.
- (2) If tension bar is too light in weight, add counter weight. If tension bar is too heavy, remove a weight.
 - To increase the weight, we recommend changing it a little by little.
 - Not to lose the unused counter weight, put it in the storage box.



- The correlation diagram between counter weight and weight adjustment spring is shown as below. Use it as reference.

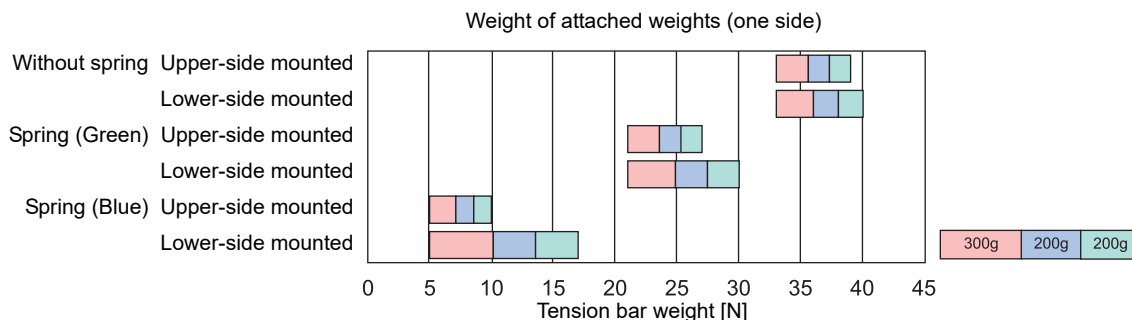

- Attach the counter weight and weight adjustment spring after adjusting the media feeding correction amount in P.2-26 "Set the media feeding".

Attach the weight adjustment spring

- 1** Loosen the screws to detach the weight adjustment shaft fixing plate.

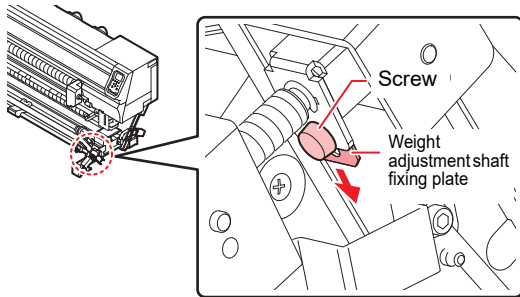

- 2** Pull out the weight adjustment shaft.
- Make sure that the holes on the weight adjustment shaft are directed horizontally, and then pull the shaft out.

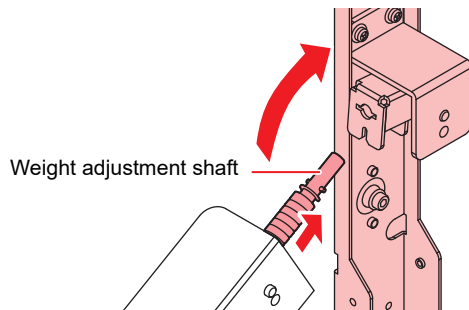

- 3** Remove the currently attached weight adjustment spring.

- Alternatively, replace it with another spring.

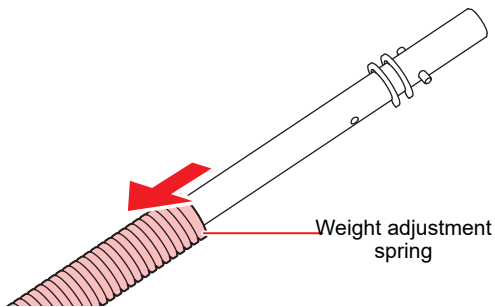

- 4** Attach the weight adjustment shaft.

- Be careful about the orientation of the guide for attaching the weight adjustment shaft when attaching the shaft.

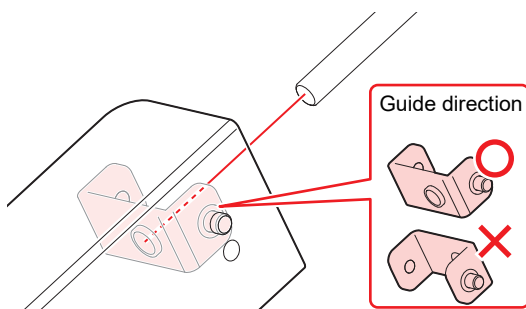

- 5** Insert the weight adjustment shaft with the holes on it directed horizontally, and insert the weight adjustment shaft fixing plate as far as it goes.

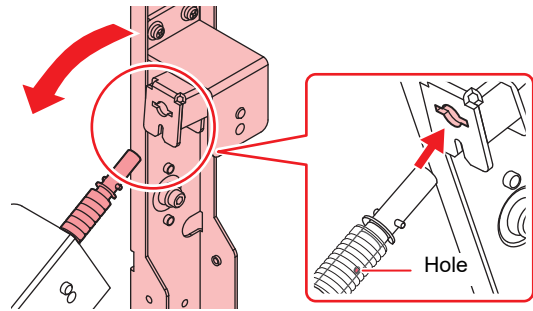

- 6** Tighten the screws.

Installing the counter weight for adjusting the tension-bar weight



- If the counter weight (50g x 28 sheets) of the right figure is attached, install a counter weight in the following manner.
- Check the tension of the media and attach an appropriate number of weights.

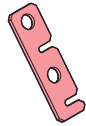

Install the proper number of the counter weight depending on the media type.
You can attach the counter weight up to 14 each for right and left.

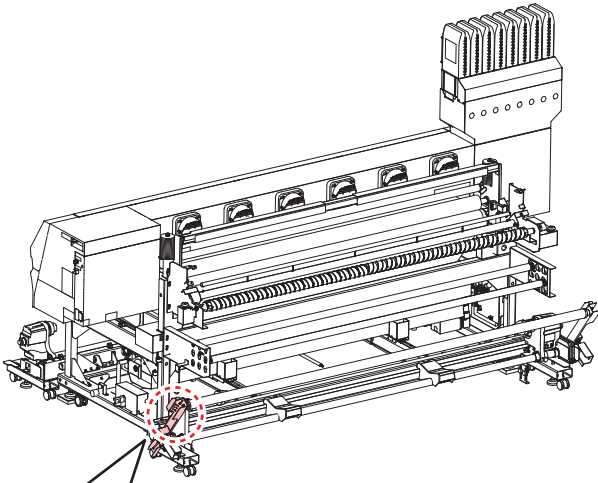

Do not remove the weight that was originally attached. Also, do not remove the screws retaining the weight.

Mounting screw
Loosen the screws when removing the counter weight.

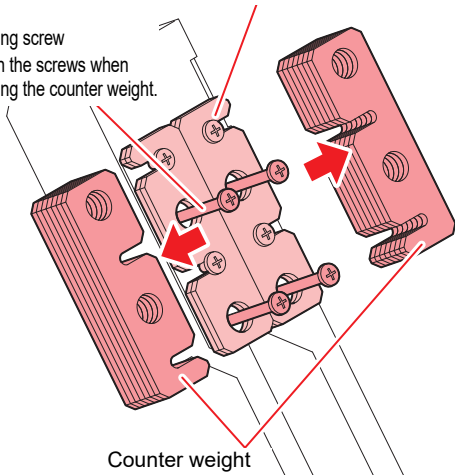

Counter weight



- If install / remove the counter weight of the bottom, please sufficiently loosen the mounting screws. If the screws are not loose enough, the counter weight will be caught by the originally attached screws, and it may not be removed.

Changing the printing origin

The position of the printing origin can be changed. Moving the LED pointer to the changing position and deciding the position.

- 1 In Local, Press .
 - It enters into the origin setting mode.

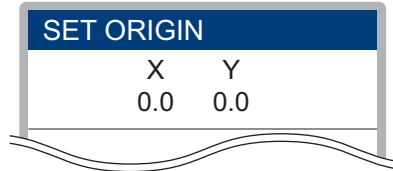

- 2 Press to set a light point of the LED pointer to the changing position.
 - Select the carriage and media, moving the point with [][][][].

- 3 After determining the origin, press the key.
 - The printing origin is changed.

Pressure roller weight adjustment

In case that the media strongly sticks and cannot peel off or the media floats with poor stuck, adjust the weight of the pressure roller.

● If the media stuck is strong

Attach the accompanying spring to the place in the red frame in the left figure. (right and left)

Pressure roller adjust spring is strong.	2 pcs
Pressure roller adjust spring is weak.	2 pcs

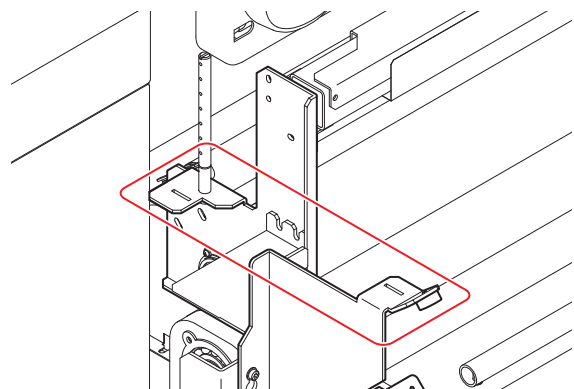

● If the media stuck is weak

Attach the accompanying weight to the place in the red frame in the left figure. (right and left)

Pressure roller ballast	40 pcs (20 pcs each)
-------------------------	----------------------



- After attaching the weight, attach the accompanying grommet by all means.

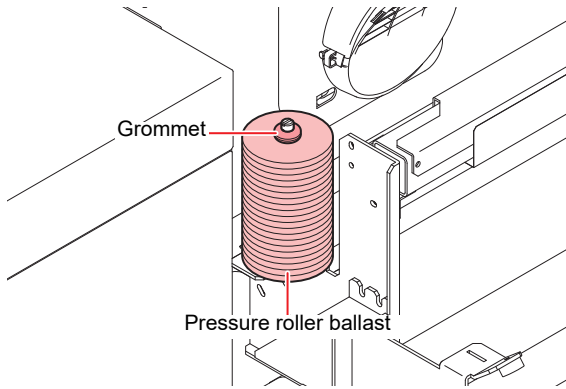

Peeling sensor positioning adjustment

The media may not be peeled normally depending on a kind of the media and the state of the adhesive. Check and adjust the position of the peeling sensor.

1 Check the position of the peeling sensor.

- Check the position of the light from the peeling sensor in the reflector at the right side of the device.

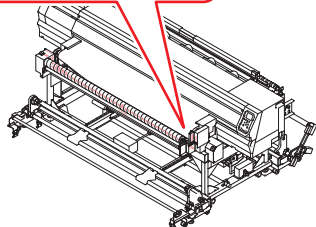
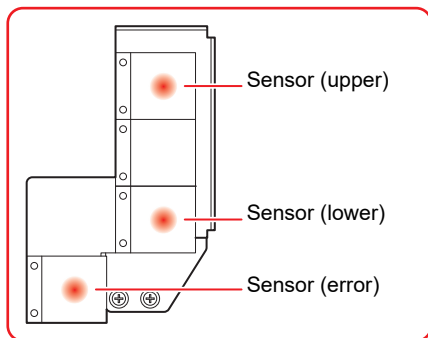

2 Adjust the position of the sensor.

- Referring to the figure, loosen two pinch screws in the peeling sensor part and adjust the sensor position.

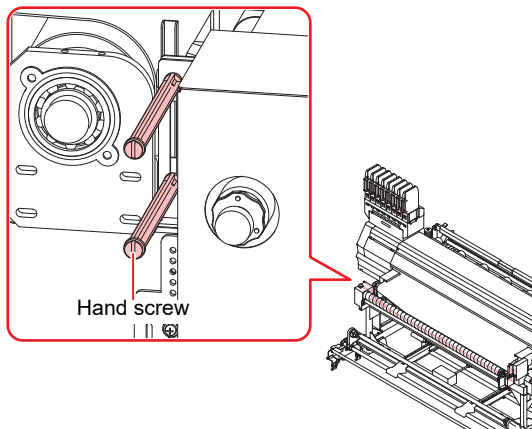

A rough position of the sensor

● If the media stuck is strong

As it is possible to detect a sensor error, adjust the sensor (lower) to the upper direction.

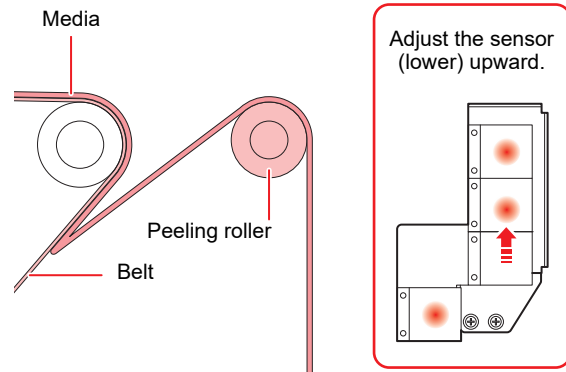

● If the media stuck is weak (In case the diameter of take-up roll is large)

Adjust the sensor (upper) to the lower direction.

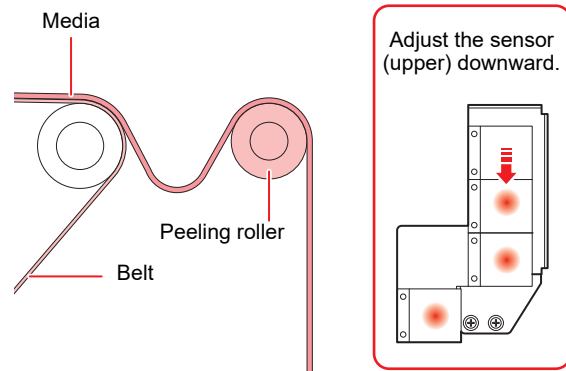

- To have a stable detection, adjust the sensor position so that the sensor light hits within approximately 5mm from the edge of each reflector.

Eradicating Media Sagging with the Curved Bar

The curved bar must be used without fail to eradicate sagging if extremely short media when the gummed parts on the left and right edges of the fabric are in the center of the fabric is used (fabric that sags heavily in the center when spread out on the floor).



Curved Bar Angle Adjustment

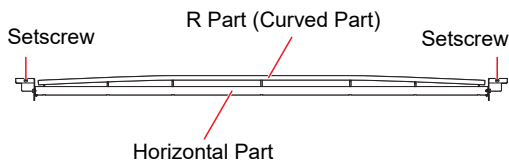

- It is necessary to adjust the location of the curved part (the angle of the curved bar) in alignment with the condition of the fabric.
- A yardstick once the fabric has been set in place with a small amount of sagging on the left and right sides of the fabric.
- Change the angle at which the curved bar will be used in alignment with the condition of the media.
Horizontal Part: Always used
R Part (Curved Part): Used on fabrics that sag in the middle.



- When using the curved bar, set the media in a center standard.

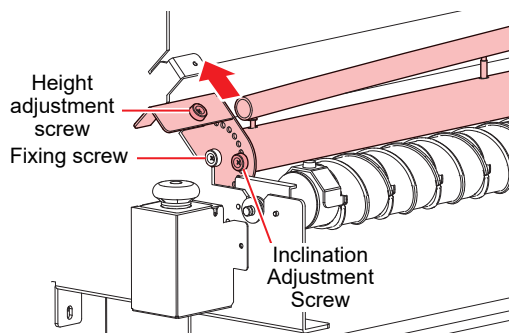

Height Adjustment Screw: Set the curved bar one stage higher if the sagging in the middle of the media is not eradicated.

Inclination Adjustment Screw: Adjusts the angle of the curved bar in alignment with the condition of the media.

1 Remove the inclination adjustment screw on the side of the curved bar and adjust the angle of the curved bar.

- (1) Remove the inclination adjustment screw and loosen the fixing screw.
- (2) Rotate the curved bar and adjust it the required amount.
- (3) Secure the curved bar in place with the inclination adjustment screw and the fixing screw.

2 Set the height adjustment screw one stage higher if the sagging in the middle of the media is not eradicated.

When not using the curved bar



- When using the curved bar, remove the slant adjust screws (right/left) and loosen the fixing screws (right/left). Afterwards, rotate the curved bar into a position where a curved section does not touch the media and then fix the screws.

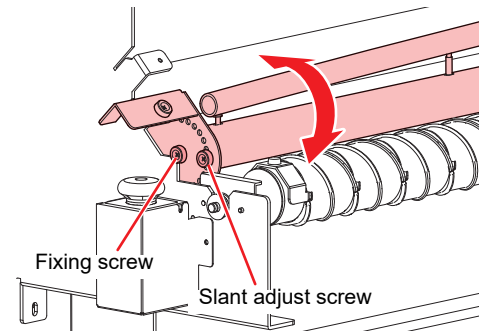

- Even when not using the curved bar, do not keep on having removed it. Otherwise, the media may interfere each other when the pressure roller was lowered.

Removing the smoother roller and replacing frames

The smoothing wrinkle roller prevents wrinkles from appearing when the fabric is attached to the feeding belt with the pressure roller.

The standard location for setting the fabric is the center. Make sure that even narrow fabric is set in the center of the feeding belt.

However, it is possible to adjust the center of the fabric in the following cases by replacing the smoothing wrinkle roller's spiral roller.

- When setting the fabric on the right-hand side to reducing printing time.
- When setting fabric with a width of 800mm or less to the left-hand or right-hand sides during normal usage to extend the life span of the adhesive.



- Do not put your hands, clothes or any other object near to the smoothing wrinkle roller when it is operating. Failure to observe this may result in them becoming caught and causing injury or broken bones.



- When using wide media, there is a risk of the edges of misaligned fabric or frays, etc., getting caught on the thumbscrews located on both sides of the smoothing wrinkle roller. Cut off the edges of fabric when setting media like this and set it accordingly.

1

Remove the setscrews of the smoothing wrinkle roller located on the left of the printer's rear surface, and then remove the smoothing wrinkle roller.

- Raise the smoothing wrinkle roller and then slide it to the left to remove it.

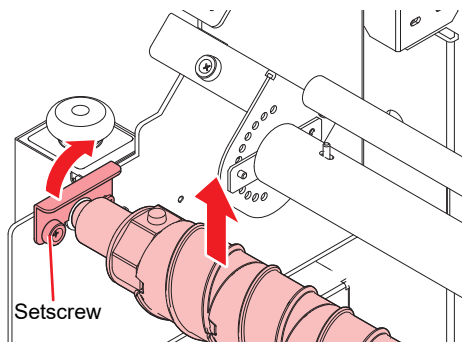

- Raise the shaft and remove it. If the smoothing wrinkle roller falls out of position, it may result in damage to the printer.

2

Loosen the hand screws on the left and right side of the smoothing wrinkle roller and then replace the pieces of the spiral roller.

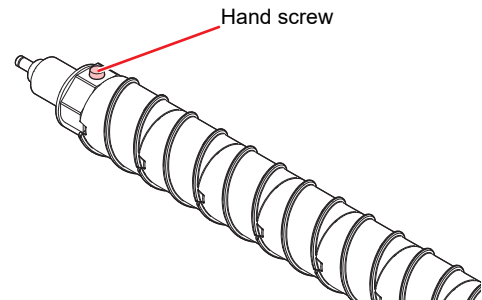

- See [Moving the Location of the Spiral Roller] (P.2-23) for details on replacing the pieces of the spiral roller.

3

Return the smoothing wrinkle roller to its original location.

Moving the Location of the Spiral Roller

It is possible to change the central location of the spiral roller as shown in the illustration below.

The smoothing wrinkle spiral roller can be split into two colors by using two different rotation directions.



1

Remove the hand screws and remove several pieces of the left-hand side of the spiral roller in accordance with the central location of the media.

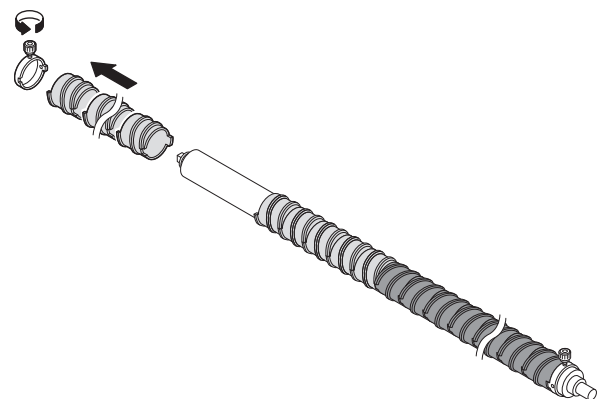

2

2 Push the pieces of the spiral roller to the left, secure them with the hand screw, and then remove the hand screw on the right.

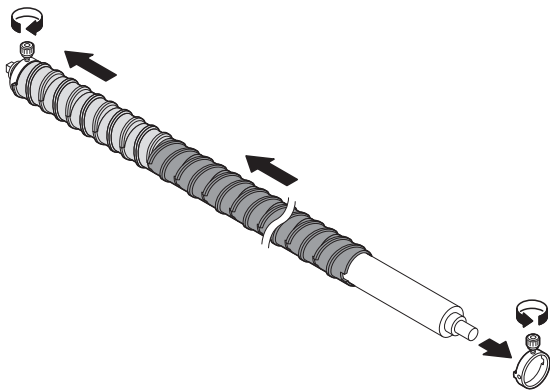

3 Add the pieces of the spiral roller removed during procedure 1 to the right-hand side.

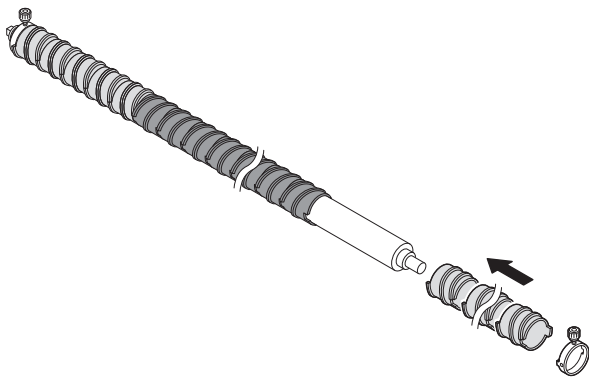

4 Secure the hand screw.

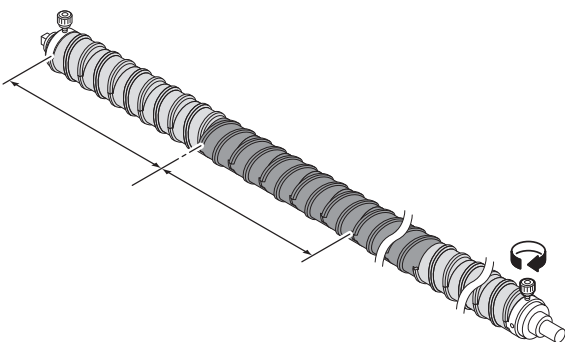

The above procedure changes the central position of the spiral roller.

Test Printing

Print a test pattern to check that there are no discharging defects such as nozzle clogging (slight touching of ink or nozzle missing).

Relationship between head row and test pattern

The relations between head row and test pattern print position are as follow.

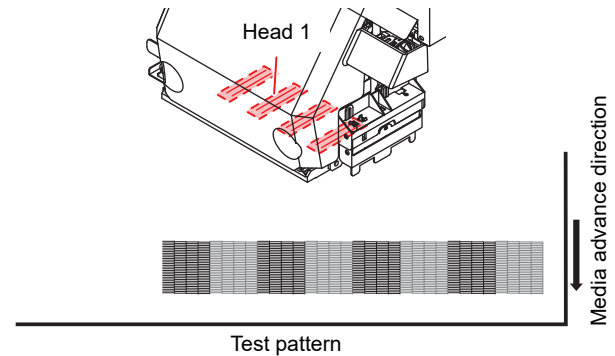

Note on test printing

- Important!** • When using leaf media, set a media of more than A3 size put horizontally. If a media with narrow width is set, printing will only be conducted to midway.
- When using a roll media, rewind the media by hand before printing so that it is not loose. When the roll media has not been rewound tightly, it may cause image quality to deteriorate.

Test Printing

Print a test pattern to check that there are no discharging defects such as nozzle clogging (slight touching of ink or nozzle missing).

In addition, you can select the orientation of the test pattern to print from two types in order to perform test printing repeatedly. Select one depending on your use.

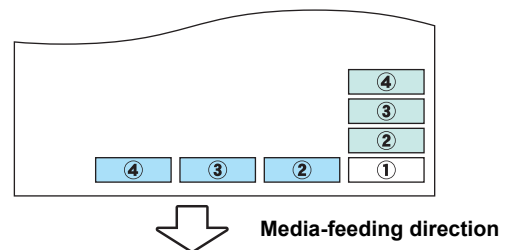

- : When the test pattern orientation is "FEED DIR."
- : When the test pattern orientation is "SCAN DIR."

Check before test printing

- If a media has been set (👉 P.2-4)
- If the origin position has been set
- If the head gap has been adjusted (👉 P.2-5)
- If the necessary settings have been configured for nozzle recovery (👉 P.4-14)

1 Press the **FUNC2** (TEST PRINT/CLEANING), and then press the **ENTER** key in LOCAL.

- The test pattern orientation screen will be displayed.

2 Press **▲▼** to select the test pattern orientation (SCAN DIR./ FEED DIR.).

- The orientation selected here will be reflected on when you will print next time.
- When performing test printing after having changed the orientation from "SCAN DIR" to "FEED DIR", the line is fed to the position of the first test printing.

3 Press the **ENTER** key.

- The NOZZLE RECOVERY setting screen will be displayed.

Important!

- If no recovery nozzles are registered in "Nozzle Recovery" in the maintenance menu (☞ P.4-14), or if the test print setting is not set to "ON" (☞ P.4-16), the test print begins. Proceed to step 6.

4 Press **▲▼** to select **NOZZLE RECOVERY** function ON/OFF.

- The orientation selected here will be reflected on when you will print next time.

ON : Print the pattern of nozzles with recovered nozzles by other nozzles, which have been registered by the nozzle recovery of the maintenance menu.

OFF : Print the pattern without Nozzle Recovery.

5 Press the **ENTER** key.

- Test printing starts.
- When the printing has been completed, the screen returns to LOCAL.

6 Check the printed test pattern.

- When the result is normal, end the operation.
- When the result is abnormal, perform head cleaning. (☞ P.2-27)

Normal pattern

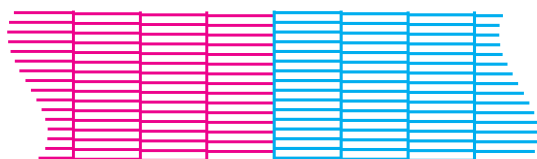

Abnormal pattern

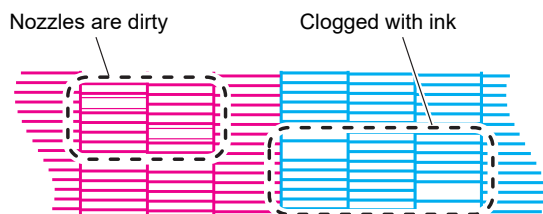

Set the media feeding

Correct the feeding rate of media.

If the correction value is not appropriate, stripes may appear on the printed image, thus resulting in a poor printing.



- When you have changed the media type, check the pattern and perform adjustment depending on the status.
- When printing with a take-up device, set the media first and then perform media correction.

Flow of media feeding correction

Perform media feeding correction as below:

1

Check that the feed correction setting value is “0”.

Referring to “Setting of Media Correction”
(☞ P.2-27).

2

Set the peeling roller to the maximum torque.

Referring to “Setting the torque limiter”
(☞ P.2-17).

3

Print the correction pattern.

Referring to “Setting of Media Correction”
(☞ P.2-27).

4

Check the pattern and adjust the counter weight of feeding/take-up tension bar.

Referring to “Tension Bar Weight Adjustment”
(☞ P.2-18).

5

If correction by counter weight adjustment is not enough, adjust the torque.

Referring to “Setting the torque limiter”
(☞ P.2-17).

6

If correction by counter weight/torque adjustment is not enough, input the correction value in the feed correction setting.

Referring to “Setting of Media Correction”
(☞ P.2-27).

Head Cleaning

About head cleaning

Check the printed test pattern result and perform cleaning depending on the status.

Select one from the three types below:

NORMAL : When any line is missing

SOFT : When only head wiping is needed (when lines are bent)

HARD : When poor image quality cannot be improved even by NORMAL or SOFT cleaning

Perform head cleaning depending on the test printing result

There are three types of head cleaning. Use one by checking the test pattern.

1 Press the **FUNC2** (TEST PRINT/CLEANING) key in LOCAL.

- CLEANING MENU will be displayed.

2 Press **▲** **▼** to select the cleaning type.

- **NORMAL** : Select this if any line is missing.
- **SOFT** : When only head wiping is desirable. (in case of bent lines)
- **HARD** : Select this if inferior printing cannot be improved even by [NORMAL] or [SOFT] cleaning.

3 Press the **ENTER** key.

4 Perform test printing again, and check the result.

- Repeat the cleaning and the test printing until the printing result becomes in normal.



When the image quality is not improved after the head cleaning.

- Clean the wiper and ink cap. (P.4-6)
- Wash the head nozzle. (P.4-7)

Setting of Media Correction

Correct the media feed amount to match the type of media you are using.

If the correction value is not appropriate, stripes may appear on the printed image, thus resulting in a poor printing.

Important!

- On completion of [MEDIA COMP.] during use of a roll media, the media returns to the printing origin. Then the roll media in the rear of this machine will slacken. Before printing, take up the slack in the roll media by hand; a loose roll media can result in an inferior image quality.
- When printing with a take-up device, set the media first and then perform media correction.

Setting of Media Correction

A pattern for media correction is printed and a media-feeding rate is corrected.



- Two bands are printed in the correction pattern.
- Make adjustment so that an even color density is obtained in the boundary between the two bands.

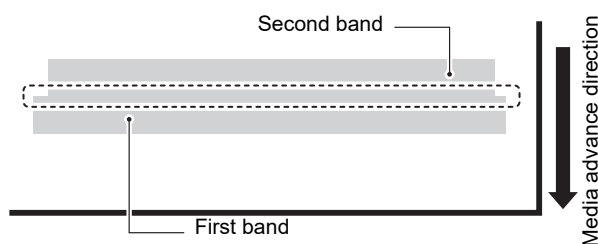

1 Set a media. (P.2-4)

2 Press the **SEL** key, and then press the **FUNC2** (ADJUST) in LOCAL.

- ADJUST MENU will be displayed.

3 Press the **ENTER** key twice to print the correction pattern

4 Check the correction pattern and enter a correction value.

- A screen for entering the correction value will be displayed.
- **Enter a correction value in “+”:**
The boundary between the two bands is widened.
- **Enter a correction value in “-”:**
The boundary between the two bands is narrowed.
- When you change the correction value by “30”, the width of the boundary changes by about 0.1 mm.

If the Positions of Dots Shift...

When the condition for printing (media thickness/ink type/etc.) has been changed, perform the following operation to correct the ink drop position for bidirectional (Bi) printing and obtain the proper printing result.

- Important!** When using leaf media, set a media of more than A3 size put horizontally. If a media with narrow width is set, printing will only be conducted to midway.

Example of a Printed Pattern

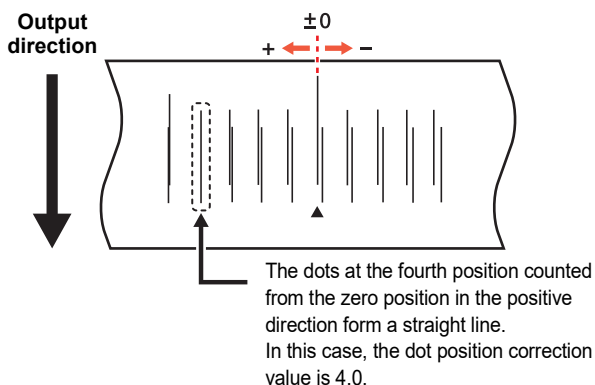

- Press the **SEL** key, and then press the **FUNC1 (ADJUST)** in LOCAL.
 - ADJUST MENU will be displayed.
- Press **▼**, and then press the **ENTER** key.
 - "DROP.POScorrect" will be selected.
- Press the **ENTER** key.
 - Printing of the Drop position correct printed pattern will start.
 - Multiple test patterns are printed. (The printed patterns are called Pattern 1, Pattern 2, Pattern 3... in the order of printing.)
- Press **▲▼** to enter a correction value of Pattern 1, and then press the **ENTER** key.
 - Corrected feeding rate: -40 to 40
 - Check the test patterns. The position where an outward feeding line and a return feeding line become one straight line is the correction value.
 - When the correction value is not between -40 and 40, adjust the height of the printing heads and then perform the operations in Step 2 and later.
- In the same way as in Step 4, enter a correction value of Pattern 2 and later, and then press the **ENTER** key.
- Press the **END/POWER** key several times to end the setting.

Printing Data

Starting a Printing Operation

- Important!** When using a roll media, rewind the media by hand before printing so that it is not loose. When the roll media has not been rewound tightly, it may cause the image quality to deteriorate.

1 Setting a Media (P.2-4)

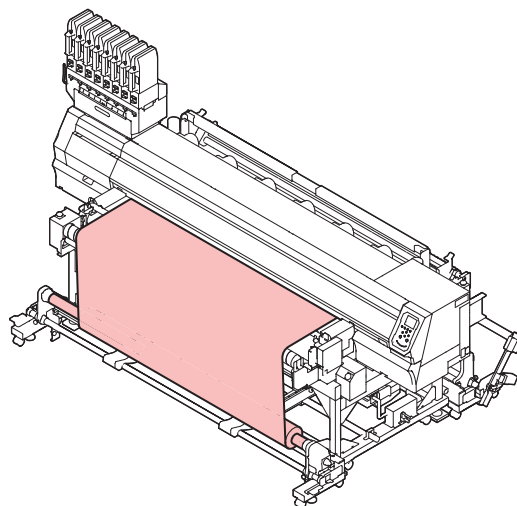

- Press **FUNC3 (REMOTE)** in LOCAL.
 - The screen changes to REMOTE, and data can be received from the PC.
- Transmit data to be printed from the PC.
 - The status indicator lamp blinks and the printing conditions are displayed.
 - For the method of data transmission, see the instruction manual for the output software.

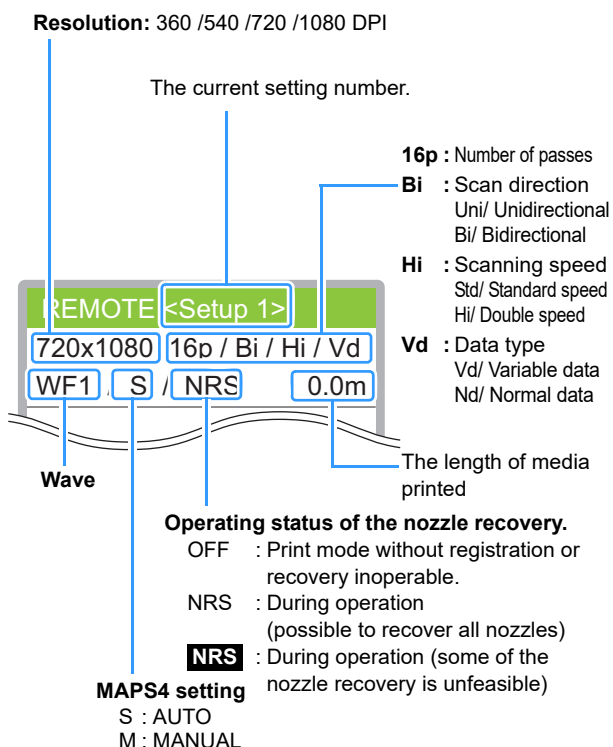

4 Start printing.

- The printing speed may change, depending on the width of the set media or the position of the print origin even when the same data is printed. This is because of a difference in resolution.

Stopping a Printing Operation

Perform the following operation when stopping a printing operation halfway.

1 Press the **FUNC3 (LOCAL) during printing.**

- The printing operation stops.
- Interrupt data sending at the PC side during the data is sent from the PC.
- Printing restarts from the interrupted data by repressing the [REMOTE] key.

Deleting Received Data (Data Clear)

When you want to stop printing, delete the already received data.

1 Press the **SEL key, and then press the **FUNC3** (DATA CLEAR) in LOCAL.****2 Press the **ENTER** key.**

- The received data is erased then it returns to the Local.

Behavior after printing has been completed**Drying Feed**

If set "DRYING FEED" in the MACHINE SETUP to other than "OFF", after completing the print, it will start the feed operation in order for the print surface to be dried by the external heater.

- Perform the feeding operation until the back edge of printing passes the heater.
- When you press the [END] key, the operation is terminated.
- When the machine has been received next data continuously, it will operate after the last data is received.

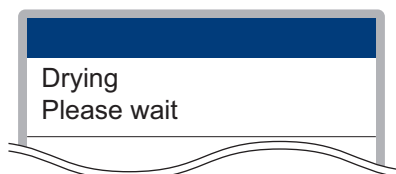
Screen display during drying feeding**To reduce waste of media**

When using the feeding/take-up device, expecting to print in an anterior edge of the media, printing is possible without waste by performing the following procedure.

Reduce waste of media anterior edge**1 Set the machine "OFF" in "TAKE-UP UNIT" of "FEEDING/TAKE-UP UNIT"**

- Details, please refer to P.2-4 "Setting Feeding and Take-up unit".

2 Start printing.

- Print to the position where the media anterior edge is wound around the paper pipe at the take-up side.

3 Press **FUNC3 (LOCAL) to stop printing.****4 Set the machine "ON" in "TAKE-UP UNIT" of "FEEDING/TAKE-UP UNIT"**

- If using the peeling function, turn "PEELING" "ON" and attach the direct-connection unit.

5 Pressing **FUNC3 (REMOTE) to re-start printing.**

Chapter 3

Setup



This chapter

describes the various setting of this machine.

About SETUP MENU	3-2	Setting the Display of Media Residual	3-16
SETUP MENU table	3-3	Setting the PG Drop Adjust.....	3-16
Register the optimal print conditions to match the use	3-4	Setting the Media Detection.....	3-16
Setting of Media Correction.....	3-5	Setting the Drying Feed.....	3-17
If the Positions of Dots Shift.....	3-6	Setting a LANGUAGE.....	3-17
Setting of Logical Seek	3-7	Setting Time.....	3-17
Setting of Overprint	3-7	Setting Unit (Temperature/ Length)	3-18
Setting of Drying Time.....	3-8	Setting a KEY BUZZER.....	3-18
Setting of Feed Speed	3-8	Setting the VIEW FEED.....	3-18
Setting of MAPS4.....	3-9	Setting the SPACE FEED MODE	3-18
Setting Auto Cleaning	3-10	Set the network.....	3-19
Setting Interval wiping	3-11	Setting event mail function.....	3-19
Setting External heater.....	3-11	Initializing the Settings.....	3-23
Setting for Improving Image Quality by Changing Media-feeding Rate (BELT COMP.).....	3-11	About NOZZLE CHECK MENU	3-24
Setting Belt Wash.....	3-11	INFORMATION MENU table	3-24
Setting Maintenance Notification Time (COUNTER LIMIT).....	3-12	Printing Check Flow.....	3-25
About MACHINE SETUP MENU	3-13	Printing Operations at “Nozzle Missing” Judgment and Error Occurrence	3-25
MACHINE SETUP MENU table	3-14	Setting the Printing Check	3-26
Setting a AUTO Power-off.....	3-15	Setting the NOZZLE RECOVERY	3-26
Setting Top Blower.....	3-15	Setting the Judgement Condition.....	3-26
		About INFORMATION MENU	3-27
		INFORMATION MENU table	3-27
		Displaying the Information	3-28

About SETUP MENU

On SETUP MENU, you can set the print conditions to match the media you usually use.

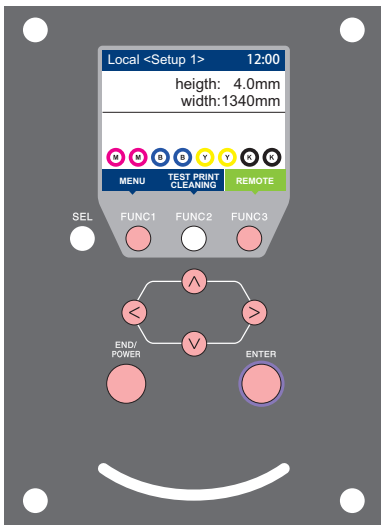

- FUNC1** : Press this to select SETUP MENU, or to switch to the previous screen.
- FUNC3** : Press this to switch to the next screen.
- ▲ ▼** : Use these to select a setting item.
- ENTER** : Press this to confirm a setting, etc..

◆ SETUP MENUs at-a-glance

Local <Setup 1> 12:00
height: 4.0mm
width:1340mm

MENU

- SETUP >
- MAINTENANCE >
- MACHINE SETUP >
- NOZZLE CHECK >
- INFORMATION >

SETUP

- SETUP 1 >
- SETUP 2 >
- SETUP 3 >
- SETUP 4 >
- Temporary >

Select "SETUP 1 to 4" or "Temporary", and then press the **ENTER** key.

SETUP 1 1/3

- FEED COMP. >
- DROP.POScorrect >
- LOGICAL SEEK HOST >
- Overprint HOST >
- DRYING TIME >

SETUP 1 1/3

- FEED COMP. >
- DROP.POScorrect >
- LOGICAL SEEK HOST >
- Overprint HOST >
- DRYING TIME >

SETUP 1 1/3

- FEED COMP. >
- DROP.POScorrect >
- LOGICAL SEEK HOST >
- Overprint HOST >
- DRYING TIME >

SETUP 1 1/3

- FEED COMP. >
- DROP.POScorrect >
- LOGICAL SEEK HOST >
- Overprint HOST >
- DRYING TIME >

SETUP 1 1/3

- FEED COMP. >
- DROP.POScorrect >
- LOGICAL SEEK HOST >
- Overprint HOST >
- DRYING TIME >

SETUP 1 2/3

- FEED SPEED HOST >
- AUTO CLEANING >
- INTERVAL WIPING OFF >
- EXTERNAL HEATER OFF >
- MAPS4 >

SETUP 1 2/3

- FEED SPEED HOST >
- AUTO CLEANING >
- INTERVAL WIPING OFF >
- EXTERNAL HEATER OFF >
- MAPS4 >

SETUP 1 2/3

- FEED SPEED HOST >
- AUTO CLEANING >
- INTERVAL WIPING OFF >
- EXTERNAL HEATER OFF >
- MAPS4 >

SETUP 1 2/3

- FEED SPEED HOST >
- AUTO CLEANING >
- INTERVAL WIPING OFF >
- EXTERNAL HEATER OFF >
- MAPS4 >

SETUP 1 3/3

- BELT COMP. ON >
- BELT WASH >
- COUNTER LIMIT >
- SETUP RESET >
- SAVE >

SETUP 1 3/3

- BELT COMP. ON >
- BELT WASH >
- COUNTER LIMIT >
- SETUP RESET >
- SAVE >

SETUP 1 3/3

- BELT COMP. ON >
- BELT WASH >
- COUNTER LIMIT >
- SETUP RESET >
- SAVE >

SETUP 1 3/3

- BELT COMP. ON >
- BELT WASH >
- COUNTER LIMIT >
- SETUP RESET >
- SAVE >

SETUP MENU table



- For each setting item below, you can set it so that the machine may operate according to the value specified when you printed from your RIP software in the connected host PC.
- **Set Item:** LOGICAL SEEK/ Overprint/ DRYING TIME/ MARGIN (LEFT and RIGHT)/ FEED SPEED
- When you operate the machine according to the contents specified with the RIP software, set each item to "Host" when registering this machine type. When you set it other than "Host", the machine operates according to the machine setup.
- For the specifying method with the RIP software, refer to the operation manual of the RIP software.

Function name		Set value	When no instruction from RIP exists* ¹	Outline	
FEED COMP. (P.3-5)		-9999 to 0 to 9999	_____	Used to print a pattern for correcting a media-feeding rate and correct it.	
DROP.POScorrect (P.3-6)		-40.0 to 0 to 40.0	_____	Used to adjust the dot position in go and return printing.	
LOGICAL SEEK (P.3-7)		HOST/ON / OFF	OFF	Sets the scan movable area during printing.	
Overprint (P.3-7)		HOST/ 1 to 9	1	Sets the number of layers in which ink is to be applied.	
DRYING TIME (P.3-7)	SCAN	HOST/ 0.0 to 9.9 sec	0 sec	Sets the time to wait for ink drying.	
	PRINT END	HOST/ 0 to 120 min	0 min		
FEED SPEED (P.3-8)		HOST/ 10 to 100%	100%	Changes the media feeding speed in printing.	
AUTO CLEANING (P.3-10)	DEFAULT, FILE, LENGTH, TIME		_____	Sets the automatic cleaning operation for the head performed before printing or during printing.	
	DEFAULT		The value differs depending on the type of ink to be used and the operating environment.		
	FILE INTERVAL	1 to 1000	_____		
	TYPE	NORMAL/ SOFT/ HARD	_____		
	LENGTH INTERVAL	0.1 to 100.0m	_____		
	TYPE	NORMAL/ SOFT/ HARD	_____		
	TIME INTERVAL	10 to 480 min	_____		
TYPE	NORMAL/ SOFT/ HARD	_____			
Cleaning Check		ON/ OFF	_____	Set to run or not a nozzle check after auto cleaning.	
EXEC.TIMING		END OF FILE/PRINTING	_____	Sets the timing for cleaning operation performed when "LENGTH" or "TIME" is selected.	
INTERVAL WIPING (P.3-11)		3 to 255 min, OFF	_____	Sets the wiping operation performed after printing is completed.	
EXTERNAL HEATER (P.3-11)		ON/OFF	_____	Used to set external heater to ON/OFF.	
MAPS4 (P.3-9)	AUTO			Perform setting to reduce stripes between passes.	
	MANUAL	SPEED	50 to 100%		
		Smoothing Lv.	0 to 25 to 100%		
BELT COMP. (P.3-11)		ON/OFF	_____	Improves print quality by reducing unevenness.	
BELT WASH (P.3-11)	BELT WASH		ON/OFF	_____	Set to automatically perform/not perform a belt wash.
	BELT FEED SPEED * ²		NORMAL/LOW	_____	Set the feeding speed for a feeding by the jog operation except printing or a confirmation feeding.
COUNTER LIMIT (P.3-12)	Adhesive		OFF, 1 to 30000m	_____	Resets the adhesive and absorb roller replacement notification time settings.
	Absorb Roller		OFF, 1 to 30000m	_____	
RESET SETTING (P.3-5)		The configuration in the settings 1-4 can be reset individually.			
SAVE (P.3-5)		Allows content set in Temporary to be saved to SETUP 1 to 4.			

*1. This is the setting value to be used for printing when setting value is not specified at the RIP software (host) side, or, you give priority to the setting value at the machine side.

*2. When doing an overprint or the feeding belt is badly dirty due to a bleed-through, set it in "LOW". If performing a jog feeding in "NORMAL", the feeding belt may not be washed enough.

Register the optimal print conditions to match the use

In this machine, you will be able to register print conditions, SETUP 1 to 4 individually to match the media in advance.

For example, after print on different types of media, return to the media always use. In such case you can set the optimum printing conditions by simply selecting the registered SETUP 1 to 4.



- Print conditions that can be pre-registered with the machine are the four types, "SETUP 1" to "SETUP 4".
- If you print with the print condition which do not often use, you will be able to set the print conditions by selecting "Temporary". If turn on the power again, settings in "Temporary" will return to the original state when it was purchased. Also if turn on the power again in "Temporary" state, it will be the state in selecting "SETUP 1".

Register the print conditions to SETUP 1 to 4

- 1 Press **FUNC1** (MENU) → **ENTER** in LOCAL.
- 2 Press **▲▼** to select SETUP 1 to 4, and press the **ENTER** key.
 - The item selected indicates ● and others show ○.
 - SETUP MENU will be displayed.
- 3 Press **▲▼** to select and set each item in the setup menu list.
 - Please see the reference page in the setup menu list for detailed configuration procedure.

How to use [Temporary]

[Temporary] is not only to set the print condition to be used only once, but also can be used for partial change of the registered SETUP "1 to 4", or for reflecting the print conditions set by the [Temporary] to SETUP 1 to 4.

● Register the print conditions in [Temporary]

Registration of the print conditions to [Temporary] can be done as the same method as to SETUP 1 to 4.

- 1 Press **FUNC1** (MENU) → **ENTER** in LOCAL.
- 2 Press **▲▼** to select "Temporary", and press the **ENTER** key.
 - SETUP MENU will be displayed.
- 3 Press **▲▼** to select and set each item in the setup menu list.
 - Please see the reference page in the setup menu list for detailed configuration procedure.

● Copy the contents of SETUP 1 to 4 to [Temporary]

You can use it with changing the part of registration contents of SETUP 1 to 4.

Select "copy" from the registration screen of [Temporary], and specify the copy source (SETUP 1 to 4).

- 1 Press **FUNC1** (MENU) → **ENTER** in LOCAL.
- 2 Press **▲▼** to select "Temporary", and press the **ENTER** key.
 - SETUP MENU will be displayed.
- 3 Press **FUNC1** (<<).
- 4 Press **▲▼** to select "SETUP RESET", and press the **ENTER** key.
- 5 Press **▲▼** to select "COPY", and press the **ENTER** key.
 - Selection screen of the copy source will be displayed.
- 6 Press **▲▼** to SELECT the copy source (SETUP 1 to 4) and press the **ENTER** key.
 - Confirmation screen of the copy will be displayed.
- 7 Press the **ENTER** key.
 - Settings selected in step 6 is copied to Temporary.
- 8 Press **▲▼** to select the setting item to be changed, and press the **ENTER** key.
 - Please see the reference page in the setup menu list for detailed configuration procedure.

● Reflect The Content Set In [Temporary] To Setup 1 To 4

- 1 Press **FUNC1 (MENU)** → **ENTER** in LOCAL.
- 2 Press **▲▼** to select “Temporary”, and press the **ENTER** key.
 - SETUP MENU will be displayed.
- 3 Press **▲▼** to select and set each item in the setup menu list.
 - Please see the reference page in the setup menu list for detailed configuration procedure.
- 4 Display the last page of Temporary and select “SAVE SETTING”, and press the **ENTER** key.
 - Selection screen of the save location will be displayed.
- 5 Press **▲▼** to select the location selected (SETUP 1 to 4), and press the **ENTER** key.
 - Save confirmation screen will be displayed.
- 6 Press the **ENTER** key.
 - Settings of Temporary will be saved to the location selected in step 5.
- 7 Press the **END/POWER** key several times to end the setting.

Reset the registered contents

Reset the contents registered to SETUP 1 to 4.

- 1 Press **FUNC1 (MENU)** → **ENTER** in LOCAL.
- 2 Press **▲▼** to select SETUP 1 to 4 to be reset and press the **ENTER** key.
 - SETUP MENU will be displayed.
- 3 Press **FUNC1 (<<)**.
- 4 Press **▲▼** to select “RESET SETTING”, and press the **ENTER** key.
 - Confirmation screen of reset settings will be displayed.
- 5 Press the **END/POWER** key several times to end the setting.

Setting of Media Correction

Correct the media feed amount to match the type of media you are using.

If the correction value is not appropriate, stripes may appear on the printed image, thus resulting in a poor printing.



- On completion of [MEDIA COMP.] during use of a roll media, the media returns to the printing origin. Then the roll media in the rear of this machine will slacken. Before printing, take up the slack in the roll media by hand; a loose roll media can result in an inferior image quality.
- When printing with a take-up device, set the media first and then perform media correction.

A pattern for media correction is printed and a media-feeding rate is corrected.



- Two bands are printed in the correction pattern.
- Make adjustment so that an even color density is obtained in the boundary between the two bands.

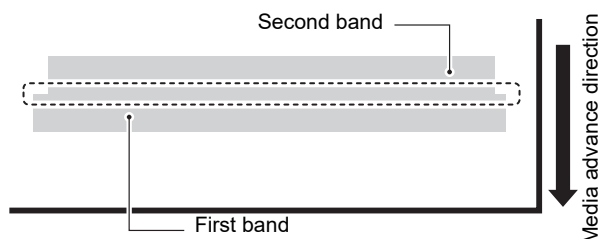

- 1 Set a media. (☞ P.2-4)
- 2 Press **FUNC1 (MENU)** → **ENTER** in LOCAL.
- 3 Press **▲▼** to select SETUP 1 to 4, and press the **ENTER** key.
 - SETUP MENU will be displayed.
- 4 Press **▲▼** to select “FEED COMP”, and press the **ENTER** key.
- 5 Press the **ENTER** key twice to print a correction pattern.
- 6 Check the correction pattern and enter a correction value.
 - A screen for entering the correction value will be displayed.
 - Enter a correction value in “+”:
The boundary between the two bands is widened.
 - Enter a correction value in “-”:
The boundary between the two bands is narrowed.
 - When you change the correction value by “30”, the width of the boundary changes by about 0.1 mm.

7 Press the **ENTER** key.

- Print a correction pattern again and check it.
- When media correction is needed, perform the operation in Step 7 to make correction.

8 Press the **END/POWER** key several times to end the setting.**Correcting Media-feeding during Printing**

A media-feeding rate can be corrected even in the remote mode or when image data is printed.

1 Press **FUNC1** (ADJUST) → **ENTER** in the Remote.**2** Press **▲▼** to enter a corrected feeding rate.

- Corrected feeding rate: -9999 to 9999
- The value entered here is reflected in the corrected feeding rate soon.

3 Press the **ENTER** key twice .

- The changed value is registered.
- When you press the [ENTER] key instead of the [END] key, the value entered here will be valid temporarily. (When you perform media detection again or turn the power OFF, the correction value is cleared.)

If the Positions of Dots Shift...

When the condition for printing (media thickness/ink type/ etc.) has been changed, perform the following operation to correct the ink drop position for bidirectional (Bi) printing and obtain the proper printing result.

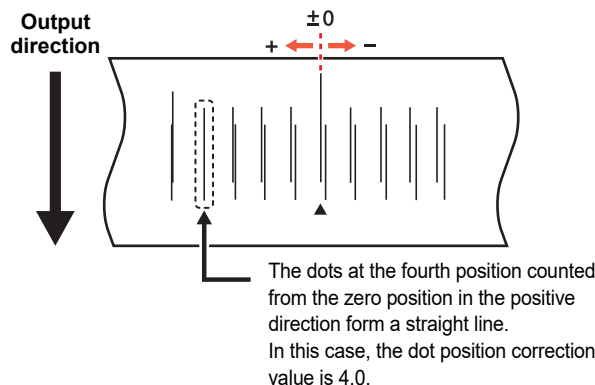
Example of a Printed Pattern**1** Set a media on the machine. (P.2-4)

- In order to print a pattern, a media that is 500 mm wide at least is necessary.

2 Press **FUNC1** (MENU) → **ENTER** in LOCAL.**3** Press **▲▼** to select **SETUP 1 to 4**, and press the **ENTER** key.

- SETUP MENU will be displayed.

4 Press **▲▼** to select “**DROP.POS correct**”, and press the **ENTER** key.**5** Press the **ENTER** key.

- Start the pattern printing.
- Multiple test patterns are printed. (The printed patterns are called Pattern 1, Pattern 2, Pattern 3... in the order of printing.)

6 Press **▲▼** to enter a correction value of **Pattern 1**, and press the **ENTER** key.

- Corrected feeding rate: -40 to 40
- Check the test patterns. The position where an outward feeding line and a return feeding line become one straight line is the correction value.
- When the correction value is not between -40 and 40, adjust the height of the printing heads and then perform the operations in Step 2 and later.

7 In the same way as in Step 4, enter a correction value of **Pattern 2** and later, and press the **ENTER** key.**8** Press the **END/POWER** key several times to end the setting.

Setting of Logical Seek

The head's operation varies depending on the LOGICAL SEEK settings, as shown in the figure below.

Movement of heads when LOGICAL seek is OFF

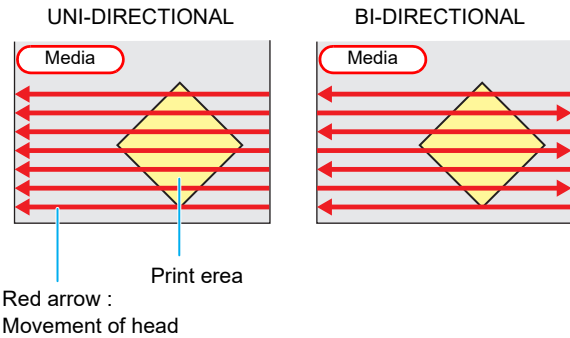

Movement of heads when LOGICAL seek is ON

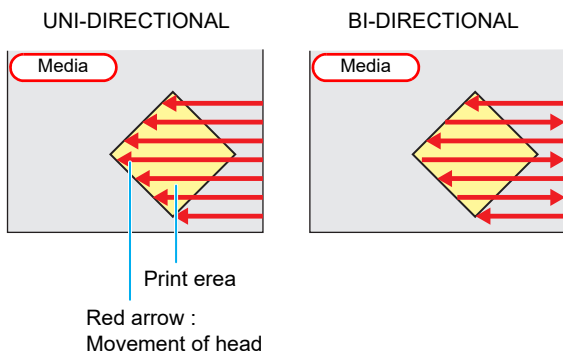

1 Press **(FUNC1) (MENU)** → **(ENTER)** in LOCAL.

2 Press **(▲) (▼)** to select **SETUP 1 to 4**, and press the **(ENTER)** key.
• SETUP MENU will be displayed.

3 Press **(▲) (▼)** to select **“LOGICAL SEEK”**, and press the **(ENTER)** key.

4 Press **(▲) (▼)** to select a set value, and press the **(ENTER)** key.
• Set value: HOST / ON / OFF

5 Press the **(END/POWER)** key several times to end the setting.

Setting of Overprint

Sets the number of layers in which ink is to be applied.

1 Press **(FUNC1) (MENU)** → **(ENTER)** in LOCAL.

2 Press **(▲) (▼)** to select **SETUP 1 to 4**, and press the **(ENTER)** key.
• SETUP MENU will be displayed.

3 Press **(▲) (▼)** to select **“Overprint”**, and press the **(ENTER)** key.

4 Press **(▲) (▼)** to set number of Overprint, and press the **(ENTER)** key.
• Setting value: Host/ 1 to 9 times

5 Press the **(END/POWER)** key several times to end the setting.

Setting of Drying Time

In the drying time setting, the following items for ink drying time are set.

- **SCAN** : Ink drying time for each scanning is set. (During bidirectional printing, the machine stops for a certain period of time specified for each of the outward and return scanning.)
- **PRINT END** : Ink drying time after printing has been complete is set.

- Important!**
- When you give priority to the setting at the RasterLink side, make the setting value "Host".
 - "SCAN" set in this machine is displayed as "Pause Time per Scan" in the RasterLink.
 - You cannot specify the print end at the RasterLink side. When you set this machine to "Host", printing will be performed in "PRINT END= 0 min." status.

1 Press **FUNC1 (MENU)** → **ENTER** in LOCAL.

2 Press **▲▼** to select **SETUP 1 to 4**, and press the **ENTER** key.
• SETUP MENU will be displayed.

3 Press **FUNC3 (>>)** .

4 Press **▲▼** to select **"DRYING TIME"**, and press the **ENTER** key.

5 Press the **ENTER** key.

6 Press **▲▼◀▶** to set drying time, and press the **ENTER** key.

- Set the drying time for scanning and after printing is completed. To enable the drying time specified in your RIP, select "Host".
- **Scanning setting value:**
Host or 0.0 sec. to 9.9 sec.
- **Print end setting value:**
Host or 0 sec. to 120 minutes.
- **Item selecting:** by the **▲▼** keys
- **Time setting:** by the **◀▶** keys

7 Press the **END/POWER** key several times to end the setting.

Setting of Feed Speed

Changes the media feeding speed in printing.

1 Press **FUNC1 (MENU)** → **ENTER** in LOCAL.

2 Press **▲▼** to select **SETUP 1 to 4**, and press the **ENTER** key.
• SETUP MENU will be displayed.

3 Press **FUNC3 (>>)**.

4 Press **▲▼** to select **"FEED SPEED"**, and press the **ENTER** key.

5 Press the **ENTER** key.

6 Press **▲▼** to select a set value, and press the **ENTER** key.
• Set value: HOST / 10 to 100%

7 Press the **END/POWER** key several times to end the setting.

- Important!**
- Depending on a print condition, there is a setting value by which the speed is not changed.

Setting of MAPS4

The MAPS (Mimaki Advanced Pass System) function to disperse the pass boundary to make the feeding stripes less visible.



- MAPS4 provides two setting options: "AUTO" and "MANUAL". Select "AUTO" or "MANUAL" according to your usage.



- Changing the MAPS4 settings may change the color tone. Check the effects before use.
- MAPS may not be effective depending on image to be printed. Use it after checking effect in advance.

● Conditions disabling MAPS function

The MAPS function may be disabled under the following conditions. In addition, the MAPS may not be effective, depending on the image to be printed.

Sb420 ink 4-colors ink set / Sb421 ink 4-colors ink set

Resolution	Pass	Scan speed
540 x 360	2 pass	High speed
720 x 720	4 pass	
720 x 1080	6 pass	
720 x 1440	8 pass	

Sb420 ink 6-colors ink set / Sb421 ink 6-colors ink set / Dd400 ink 8-colors ink set

Resolution	Pass	Scan speed
540 x 360	4 pass	High speed
720 x 720	8 pass	
720 x 1080	12 pass	
720 x 1440	16 pass	

Rc400 ink 8-colors ink set

Resolution	Pass	Scan speed
720 x 1080	12 pass	High speed
720 x 1440	16 pass	

Ac400 ink 8-colors ink set

Resolution	Pass	Scan speed
720 x 1440	16 pass	High speed

Rc500 ink 8-colors ink set

Resolution	Pass	Scan speed
720 x 1080	12 pass	High speed

Sb420 at the ink set of Sb420+TP420 4+4colors / Sb421 at the ink set of Sb421+TP420 4+4colors

Resolution	Pass	Scan speed
540 x 360	4 pass	High speed
720x 720	8 pass	
720x 1080	12 pass	
720x 1440	16 pass	

Setting MAPS4 Function (AUTO)

1 Press **(FUNC1) (MENU)** → **(ENTER)** in LOCAL.

2 Press **(▲) (▼)** to select **SETUP 1 to 4**, and press the **(ENTER)** key.

- SETUP MENU will be displayed.

3 Press **(FUNC3) (>>)**.

4 Press **(▲) (▼)** to select **"MAPS4"**, and press the **(ENTER)** key.

5 Press **(▲) (▼)** to select **"AUTO"**, and press the **(ENTER)** key.

- To select "MANUAL" for the setting, refer to P.3-9 "Setting MAPS4 Function (MANUAL)".

6 Press the **(END/POWER)** key several times to end the setting.

Setting MAPS4 Function (MANUAL)

1 Press **(FUNC1) (MENU)** → **(ENTER)** in LOCAL.

2 Press **(▲) (▼)** to select **SETUP 1 to 4**, and press the **(ENTER)** key.

- SETUP MENU will be displayed.

3 Press **(FUNC3) (>>)**.

4 Press **(▲) (▼)** to select **"MAPS4"**, and press the **(ENTER)** key.

5 Press **(▲) (▼)** to select **"MANUAL"**, and press the **(ENTER)** key.

- To select "AUTO" for the setting, refer to P.3-9 "Setting MAPS4 Function (AUTO)".

6 Press **(▲) (▼)** to select the **"SPEED" (50 to 100%)**, and press the **(ENTER)** key.

- Select a speed for printing. By using standard quality printing as reference, set in the direction of minus (-) to decrease the print speed, and set in the direction of plus (+) to increase the print speed.

Important! • If the speed is changed, **NOZZLE RECOVERY** (☞ P.3-26) may not become effective. Check in advance before use.

7 Press **(▲) (▼)** to select the **"Smoothing Lv."**, and press the **(ENTER)** key.

8 Press **(▲) (▼)** to change the smoothing level, and press the **(ENTER)** key.

- Set Value: 0 to 100% (set in units of 5%)
- The MAPS4 effect become strong as the set value increase, and become weak as the set value decrease.

9 Press the **(END/POWER)** key several times to end the setting.

Setting Auto Cleaning

You can set the machine so that it counts the number of printed files or the length or time after printing has been completed, and performs cleaning automatically if required. You can select the auto cleaning setting from four types below:

- **DEFAULT** : The cleaning operation units and intervals differ depending on the type of ink to be used or the operating environment. Refer to the table below for more information.
- **PAGE** : Set the cleaning intervals by the number of printed files.
- **LENGTH** : Set the cleaning intervals by the printed length.
- **TIME** : Set the cleaning intervals by the printed time.

● Conditions for Cleaning in "DEFAULT" Mode

The conditions for cleaning differ depending on the type of ink to be used and the operating environment as indicated in the table below.

Ink type	Operation Units	Operating Environment			Operation Timing	Cleaning Type
		Up to 30°C	30 to 35°C	35°C or higher		
Sb420	LENGTH	—	30m	10m	PRINTING	Normal
Sb421	LENGTH	—	30m	10m	PRINTING	Normal
Dd400	LENGTH	—	—	30m	PRINTING	Normal
TP400	TIME	480min	120min	60min	END OF FILE	Normal
Rc400	LENGTH	—	50m	30m	PRINTING	Soft
Ac400	LENGTH	—	50m	30m	PRINTING	Normal
Rc500	LENGTH	—	50m	30m	PRINTING	Soft
Sb420+ TP400	TIME	480min	120min	60min	END OF FILE	Normal
Sb421+ TP400	TIME	480min	120min	60min	END OF FILE	Normal

Important!

- The "—" mark in the table indicates that the auto-cleaning operation is not carried out.
- If you select "DEFAULT", the cleaning type is automatically set to "NORMAL". Even if you select a configuration other than "DEFAULT", the cleaning operation is carried out automatically once the interval set with the conditions specified in the table above is exceeded.

The functions listed below are also available.

- **Cleaning Check function**
Automatic nozzle check after auto cleaning can be set.
- **Select Cleaning Operation Timing function**
The cleaning operation timing can be set when "LENGTH" or "TIME" is selected as the unit for cleaning.

The machine can perform a stable printing operation with its heads always kept clean.

1 Press **(FUNC1) (MENU)** ➔ **(ENTER)** in LOCAL.

2 Press **(▲) (▼)** to select **SETUP 1 to 4**, and press the **(ENTER)** key.

- SETUP MENU will be displayed.

3 Press **(FUNC3) (>>)**.

4 Press **(▲) (▼)** to select **"AUTO CLEANING"**, and press the **(ENTER)** key.

5 Press the **(ENTER)** key, and press **(▲) (▼)** to select the type of auto cleaning.

- There are "DEFAULT", "PAGE", "LENGTH" and "TIME" for auto cleaning.

DEFAULT : When the set cleaning timing has been reached, the machine performs head cleaning automatically.

FILE : When the set number of prints has been completed, the machine performs head cleaning automatically.

LENGTH : When the set length has passed, the machine performs head cleaning automatically.

TIME : When the set time has passed, the machine performs head cleaning automatically.

- If you have selected "DEFAULT", proceed to Step 8.

6 Press **(ENTER)**, and press **(▲) (▼)** to select the cleaning interval.

- Depending on the auto cleaning type selected in the Step 3, the setting value differs.

For FILE : 1 to 1000 file

For LENGTH : 0.1 to 100.0m (in 0.1m increment)

For TIME : 10 to 480min (in 10min increment)

7 Press the **(ENTER)** key, and press **(▲) (▼)** to select the cleaning type.

- **Set Value:** NORMAL/ SOFT/HARD

8 Press the **(ENTER)** key, and press **(▲) (▼)** to select "Cleaning Check".

9 Press the **(ENTER)** key, and press **(▲) (▼)** to select set value.

- **Set Value:** ON/ OFF
- If you have selected "FILE" at step 5, proceed to Step 12.

10 Press the **(ENTER)** key, and press **(▲) (▼)** to select "EXEC.TIMING".

11 Press the **(ENTER)** key, and press **(▲) (▼)** to select set value.

- There are "END OF FILE" and "PRINTING" for set values.

END OF FILE : Carries out the cleaning operations between files after the cleaning interval configured under "LENGTH" or "TIME" in Step 6 has passed.

PRINTING : Stops printing and starts the cleaning operation immediately after the cleaning interval configured under "LENGTH" or "TIME" in Step 6 has passed.

12 Press the **(ENTER)** key.

13 Press the **(END/POWER)** key several times to end the setting.

Important!

- Depending on the state of the heads, etc., the image quality deterioration may not be improved even with this function performed. In this case, contact our service office or the distributor in your region.

Setting Interval wiping

When the set time has passed, nozzle face of the head is cleaned automatically to remove ink droplets on the nozzle face.

In case that deflection, nozzle missing, or symptom which ink droplets fall down occurred, set the interval between each operation shorter.

- 1 Press **FUNC1** (MENU) → **ENTER** in LOCAL.
- 2 Press **▲** **▼** to select **SETUP 1 to 4**, and press the **ENTER** key.
 - SETUP MENU will be displayed.
- 3 Press **FUNC1** (<<) .
- 4 Press **▲** **▼** to select “**INTERVAL WIPING**”, and press the **ENTER** key.
- 5 Press **▲** **▼** to set intervals.
 - Set Value : 3 to 255 Minutes, OFF
 - When [OFF] is set, periodical wiping is not executed.
- 6 Press the **ENTER** key.
- 7 Press the **END/POWER** key several times to end the setting.

Setting External heater

Used to set external heater to ON/OFF.

- 1 Press **FUNC1** (MENU) → **ENTER** in LOCAL.
- 2 Press **▲** **▼** to select **SETUP 1 to 4**, and press the **ENTER** key.
 - SETUP MENU will be displayed.
- 3 Press **FUNC1** (<<) .
- 4 Press **▲** **▼** to select “**EXTERNAL HEATER**”, and press the **ENTER** key.
- 5 Press **▲** **▼** to select set value.
 - Set Value: ON/OFF
- 6 Press the **ENTER** key.
- 7 Press the **END/POWER** key several times to end the setting.

Setting for Improving Image Quality by Changing Media-feeding Rate (BELT COMP.)

Setting the BELT COMP. to ON allows for improved print quality.

Set belt comp. to ON at times when you are concerned about unevenness during printing or seam joint of the belt.

- Important!** • When you change setting of the belt correction, set the feeding correction. (☞ P.2-27)

- 1 Press **FUNC1** (MENU) → **ENTER** in LOCAL.
- 2 Press **▲** **▼** to select **SETUP 1 to 4**, and press the **ENTER** key.
 - SETUP MENU will be displayed.
- 3 Press **FUNC1** (<<) .
- 4 Press **▲** **▼** to select “**BELT COMP.**”, and press the **ENTER** key.
- 5 Press **▲** **▼** to select set value.
 - Set Value: ON/OFF
- 6 Press the **ENTER** key.
- 7 Press the **END/POWER** key several times to end the setting.

Setting Belt Wash

Using the belt wash feature makes it possible to remove ink stains which go through the media and appear on the feeding belt.

- Important!** • The belt wash function only activates during feeding belt operation.
 • The best wash function will not operate, even when set to ON, if the feeding belt is not in operation.

- 1 Press **FUNC1** (MENU) → **ENTER** in LOCAL.
 - 2 Press **▲** **▼** to select **SETUP 1 to 4**, and press the **ENTER** key.
 - SETUP MENU will be displayed.
 - 3 Press **FUNC1** (<<) .
 - 4 Press **▲** **▼** to select “**BELT WASH**”, and press the **ENTER** key.
 - 5 Press **▲** **▼** to select set value.
 - Set Value: ON/OFF
- Important!** • Because the absorb roller may be deformed, when setting in “OFF”, make sure to remove it in advance. (☞ P.4-23)

6 Press the **ENTER** key.

7 Press **▲▼** to select “BELT FEED SPEED”, and press the **ENTER** key.

- When the setting of “BELT WASH” is “OFF”, “BELT FEED SPEED” can not be indicated.

8 Press **▲▼** to select set value, and press the **ENTER** key.

- Set value: NORMAL, LOW



- When doing an overprint or the feeding belt is badly dirty due to a bleed-through, set it in “LOW”. If performing a jog feeding in “NORMAL”, the feeding belt may not be washed enough.

9 Press the **END/POWER** key several times to end the setting.

Setting Maintenance Notification Time (COUNTER LIMIT)

Maintenance notification times (for adhesive replacement and absorb roller cleaning) can be set based on print length (in meters).



- Setting maintenance notification times allows you to carry out work without being concerned with maintenance times since the machine will notify you before maintenance needs to be performed.
- No maintenance notification will occur if no setting is provided.

1 Press **FUNC1** (MENU) → **ENTER** in LOCAL.

2 Press **▲▼** to select SETUP 1 to 4, and press the **ENTER** key.

- SETUP MENU will be displayed.

3 Press **FUNC1** (<<) .

4 Press **▲▼** to select “COUNTER LIMIT”, and press the **ENTER** key.

5 Press **ENTER** and press **▲▼** to select “Adhesive” or “Absorb Roller”.

6 Press **ENTER** and press **▲▼** to set print length.

- Adhesive settings: OFF, 1 to 30000m (10m intervals)
- Absorb roller settings: OFF, 1 to 30000m (10m intervals)



- The unit of input can be changed as 10m → 100m → 1000m → 10000m by every pushing the **FUNC2** key.

7 Press the **ENTER** key.

8 Press the **END/POWER** key several times to end the setting.

About MACHINE SETUP MENU

Common settings are functions for using this machine easily.
The following items can be set in machine setups.

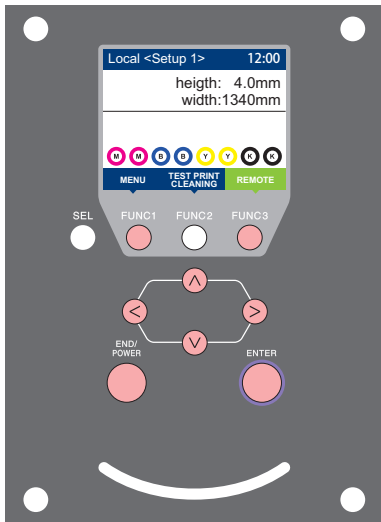

(FUNC1) : Press this to select MACHINE SETUP MENU, or to switch to the previous screen.

(FUNC3) : Press this to switch to the next screen.

(▲)(▼) : Use these to select a setting item.

(ENTER) : Press this to confirm a setting, etc..

◆ MACHINE SETUP MENUS at-a-glance

The following table summarizes the navigation sequence shown in the 'at-a-glance' section:

Screen	Item	Action
1	MACHINE SETUP	FUNC1
2	FEEDING/TAKE-UP UNIT	▲
3	Top blower	▼
4	MEDIA REMAIN	▲
5	HEAD HEIGHT	▼
6	FEEDING/TAKE-UP UNIT	▲
7	PG DROP ADJUST	▼
8	MEDIA DETECT	▲
9	DRYING FEED	▼
10	LANGUAGE	▲
11	TIME	▼
12	UNIT/TEMP.	▲
13	UNIT/LENGTH	▼
14	KEY BUZZER	▲
15	VIEW FEED	▼
16	SPACE FEED MODE	▲
17	NETWORK	▼
18	EVENT MAIL	▲
19	RESET	▼
20	NETWORK	▲

MACHINE SETUP MENU table

Function name		Set value	Default	Meaning
AUTO Power-off (☞ P.3-15)		NONE/ 10 ~ 600min	30min	When no operation has been performed for the set time, the power supply is automatically turned "OFF".
FEEDING/ TAKE-UP UNIT (☞ P.2-4)	FEEDING UNIT	ON/ OFF	ON	Set whether to use or not to use feeding unit.
	FEEDING TENSION BAR	ON/ OFF	OFF	Set whether to use or not to use feeding tension bar.
	TAKE-UP UNIT	ON/ OFF	ON	Set whether to use or not to use take-up unit.
	PEELING UNIT	ON/ OFF	OFF	Sets whether or not the peeling function is used.
	FEEDING/ TAKE-UP SW	Continuance/ Temporary	Continuance	Set how to operate when the ON/OFF switch for feeding/take-up device is pressed.
Top blower (☞ P.3-15)	ON	AUTO/ STORONG/ WEAK	AUTO	Set the operation of the top blower in print.
	OFF			
MEDIA REMAIN (☞ P.3-16)		ON/ OFF	OFF	You can control the remaining amount of media.
HEAD HEIGHT (☞ P.2-5)		2.0 to 7.0 mm		Set the head height.
PG DROP ADJUST (☞ P.3-16)				Adjust the outward and return ink drop positions during bidirectional printing.
MEDIA DETECT (☞ P.3-16)	INPUT THICKNESS	ON/ OFF	ON	Set whether to enter the thickness of the media to be used during media detection.
DRYING FEED (☞ P.3-17)		OFF/ 100 to 1000mm	OFF	Set the length of the media to feed after printing is complete.
LANGUAGE (☞ P.3-17)		日本語 / English / Español / Italiano / Português / 中文 / Korean / Türkçe	English	Displayed language is changed.
TIME (☞ P.3-17)				Time difference is corrected.
UNIT/ TEMP. (☞ P.3-18)		°C (Centigrade)/°F (Fahrenheit)	°C	A unit for displaying temperature is set.
UNIT/ LENGTH (☞ P.3-18)		mm / inch	mm	A unit for displaying length and area is set.
KEY BUZZER (☞ P.3-18)		ON / OFF	ON	A buzzer sound when keys are pressed is set.
VIEW FEED (☞ P.3-18)		ON / OFF	ON	Set whether media feeding is performed for checking the result of the test printing etc. or not.
SPACE FEED MODE (☞ P.3-18)		INTERMITTENT / CONTINUOUS	INTERMITTENT	Change the feed mode of the margin included in the image data.
NETWORK (☞ P.3-19)	Set the network.			
	Check IP Addr.	The IP address currently used by this machine is displayed.		
	Check MAC Addr.	The IP address currently used by this machine is displayed.		
	DHCP	ON / OFF		When it is ON, the IP address given by the DHCP server is used.
	AutoIP	ON / OFF		When it is ON, the IP address is determined by the AutoIP protocol. However, DHCP is ON, DHCP has priority.
	IP Address *1	Set the IP address used by this machine.		
	Default Gateway *1	Set the default gateway used by this machine.		
	DNS Address *1	Set the DNS server address used by this machine.		
	SubNet Mask *1	Set the digit number of the subnet mask used by this machine.		

Function name		Set value		Default	Meaning	
EVENT MAIL	Mail Delivery (P.3-19)	ON / OFF		OFF	Set whether you send/ do not send the e-mail when the set event occurs.	
	Select Event (P.3-20)	Print Start Event	ON / OFF	OFF	Set whether you send/ do not send the e-mail at the start of printing.	
		Print End Event	ON / OFF	OFF	Set whether you send/ do not send the e-mail at the end of printing.	
		Error Event	ON / OFF	OFF	Set whether you send/ do not send the e-mail when a error occurs.	
		Warning Event	ON / OFF	OFF	Set whether you send/ do not send the e-mail when a warning occurs.	
		Other Event	ON / OFF	OFF	Set whether you send/ do not send the e-mail when an event other than the above occurs.	
	Mail Address (P.3-20)	Set the e-mail address to which you send the event mail.		Alphanumeric characters and symbols (within 96 characters)		
	Message Subject (P.3-20)	Set the characters to write in the subject of the event mail.		Alphanumeric characters and symbols (within 8 characters)		
	Server Setup (P.3-21)	SMTP Address		Set the SMTP server.		
		SMTP Port No.		Set the SMTP port number.		
		SENDER ADDRESS		Set the e-mail address to be used as the sender mail address.		
		Authentication	POP before SMTP	Set the SMTP server authentication method (SMTP authentication).		
			SMTP Authentication			
			OFF			
		User Name *2		Set the user name used for the authentication.		
Pass Word *2		Set the password used for the authentication.				
POP3 Address *3		Set the POP server.				
APOP *3		Set ON/ OFF of APOP.				
Transmit Test (P.3-22)	Send the test e-mail.					
RESET (P.3-23)					All setting values are returned to the status default.	

*1. Settable when both of DHCP and AutoIP are [OFF]

*2. Settable only when Auth. is not OFF

*3. Settable only when Auth. is POP before SMTP

Setting a AUTO Power-off

When no operation has been performed for the set time, the power supply is automatically turned "OFF".

- 1 Press **FUNC1 (MENU)** (twice) → **ENTER** in LOCAL.
• MACHINE SETUP MENU will be displayed.
- 2 Press **▲ ▼** to select "AUTO POWER OFF", and press the **ENTER** key.
- 3 Press **▲ ▼** to select a set value, and press the **ENTER** key.
• Set Value: none, 10 to 600min
- 4 Press the **END/POWER** key several times to end the setting.

Setting Top Blower

Set the operation of the top blower in print.
Turn the top blower setting "ON", and you can set the strength for the blower.

- 1 Press **FUNC1 (MENU)** (twice) → **ENTER** in LOCAL.
• MACHINE SETUP MENU will be displayed.
- 2 Press **▲ ▼** to select "Top blower", and press the **ENTER** key.
- 3 Press **▲ ▼** to select "ON", and press the **ENTER** key.
ON : You can choose the air volume of the blower.
OFF : The top blower does not work while printing process. Proceed to step 6.
- 4 Press **▲ ▼** to select "STRENGTH", and press the **ENTER** key.

5 Press **▲▼** to select a set value (AUTO/ STRONG/ WEAK), and press the **ENTER** key.

- Set value: ON/ OFF

6 Press the **END/POWER** key several times to end the setting.

Setting the Display of Media Residual

Whether the screen displays the remaining amount of a media is set.

When the media remaining amount display is turned to "ON"	the remaining amount of a media is displayed in Remote. (However, when a leaf media is used, the length of the media to be printed is displayed.)
When the media remaining amount display is turned to "OFF"	the remaining amount of a media is not displayed in the Remote.



- The amount of a media that has been fed by the printing and jog keys is reflected in the remaining amount of a media.
- The length of a media (initial value of the remaining amount) is entered when a roll media is detected. (P.2-15)
- The setting configured here does not become effective unless media detection is performed after the setting has been complete.

1 Press **FUNC1** (MENU) **▶▼** (twice) **▶** **ENTER** in LOCAL.

- MACHINE SETUP MENU will be displayed.

2 Press **▲▼** to select "MEDIA REMAIN", and press the **ENTER** key.

3 Press **▲▼** to select ON/OFF.

4 Press the **ENTER** key.

5 Press the **END/POWER** key several times to end the setting.



- When set "ON" the media remaining display, you can print the list of current media remaining amount and the date. (P.2-15)

Setting the PG Drop Adjust

Adjust the outward and return ink drop positions during bidirectional printing.

PG Drop Adjust adjusts the ink drop positions at two points where the head height is not the same, so that high quality printing can be realized by automatically adjusting the ink drop positions even if the head height changes.

1 Press **FUNC1** (MENU) **▶▼** (twice) **▶** **ENTER** in LOCAL.

- MACHINE SETUP MENU will be displayed.

2 Press **FUNC3** (>>).

3 Press **▲▼** to select "PG DROP ADJUST", and press the **ENTER** key.

4 Loosen the carriage height adjustment screw and press the **ENTER** key.

- Loosen the screen by referring to P.2-5 "Adjusting the Head Height".

5 With the head height set as 3 mm, tighten the height adjustment screw.

6 Press the **ENTER** key twice.

- Ink drop position adjustment patterns 1 to 5 will be printed.

7 Correct the dot positions in patterns 1 to 5 by referring to P.3-6 "If the Positions of Dots Shift...".

8 By referring to steps 4 to 7, change the head height to 4 mm and then correct the dot positions in patterns 1 to 5.

9 Press the **END/POWER** key several times to end the setting.

Setting the Media Detection

Sets the Media Detect function.

Setting of Media Thickness	Set whether to enter the thickness of the media during media detection.
----------------------------	---

1 Press **FUNC1** (MENU) **▶▼** (twice) **▶** **ENTER** in LOCAL.

- MACHINE SETUP MENU will be displayed.

2 Press **FUNC3** (>>).

3 Press **▲▼** to select "INPUT THICKNESS", and press **ENTER**.

4 Press **▲▼** to select "ON/OFF", and press the **ENTER** key.

5 Press the **END/POWER** key several times to end the setting.

Important!

- To improve image quality for printing, we recommend selecting "ON" in step 4.

Setting the Drying Feed

After printing, set the media feed length for drying uniformly to the end of the media.



- According to the position of your external heater, please configure that the rear end of printing can pass through the heater.

1 Press **FUNC1** (MENU) → **▼** (twice) → **ENTER** in LOCAL.

- MACHINE SETUP MENU will be displayed.

2 Press **FUNC3** (>>).

3 Press **▲▼** to select "DRYING FEED", and press the **ENTER** key.

4 Press the **ENTER** key.

- "DRYING FEED" will be selected.

5 Press **▲▼** to input the feed length of media, and press the **ENTER** key.

6 Press the **END/POWER** key several times to end the setting.

Setting a LANGUAGE

You can change the displayed language.

1 Press **FUNC1** (MENU) → **▼** (twice) → **ENTER** in LOCAL.

- MACHINE SETUP MENU will be displayed.

2 Press **FUNC3** (>>).

3 Press **▲▼** to select "LANGUAGE", and press the **ENTER** key .

4 Press **▲▼** to select language, and press the **ENTER** key .

5 Press the **END/POWER** key several times to end the setting.

Setting Time

You can set time of your country (time difference).

1 Press **FUNC1** (MENU) → **▼** (twice) → **ENTER** in LOCAL.

- MACHINE SETUP MENU will be displayed.

2 Press **FUNC3** (>>).

3 Press **▲▼** to select "TIME", and press the **ENTER** key.

4 Press **▲▼◀▶** to enter time, and press the **ENTER** key.

- Year/Month/Day/Time selecting:
by the [◀][▶]
- Year/Month/Day/Time inputting:
by the [▲][▼]

5 Press the **END/POWER** key several times to end the setting.



- -20 hours to +4 hours can be set.

Setting Unit (Temperature/ Length)

Units used by this machine are set.

- 1 Press **FUNC1** (MENU) → **▼** (twice) → **ENTER** in LOCAL.
• MACHINE SETUP MENU will be displayed.
- 2 Press **FUNC3** (>>).
- 3 Press **▲▼** to select “UNIT/TEMP.” or “UNIT/LENGTH”, and press the **ENTER** key.
- 4 Press **▲▼** to select a set value, and press the **ENTER** key.
• Set value of temperature: °C / °F
• Set value of length: mm / inch
- 5 Press the **END/POWER** key several times to end the setting.

Setting a KEY BUZZER

You can turn off the buzzer sound when pressing the key.

- 1 Press **FUNC1** (MENU) → **▼** (twice) → **ENTER** in LOCAL.
• MACHINE SETUP MENU will be displayed.
- 2 Press **FUNC3** (>>) twice.
- 3 Press **▲▼** to select “KEY BUZZER”, and press the **ENTER** key.
- 4 Press **▲▼** to select a set value, and press the **ENTER** key.
• Set value: ON/ OFF
- 5 Press the **END/POWER** key several times to end the setting.



- When the key buzzer is set to “OFF”, the buzzer sound for errors, warnings, operation completion, etc. cannot be shut off.

Setting the VIEW FEED

Set whether media feeding is performed for checking the result of the test printing etc. or not.

- 1 Press **FUNC1** (MENU) → **▼** (twice) → **ENTER** in LOCAL.
• MACHINE SETUP MENU will be displayed.
- 2 Press **FUNC3** (>>) twice.
- 3 Press **▲▼** to select “VIEW FEED”, and press the **ENTER** key .
- 4 Press **▲▼** to select a set value, and press the **ENTER** key .
• Set value: ON/ OFF
- 5 Press the **END/POWER** key several times to end the setting.

Setting the SPACE FEED MODE

Change the feed mode of the margin included in the image data (the space of no data to be printed). If print data with much margin, set to “continuous”, then the print time can be shorten.

- 1 Press the **FUNC1** (MENU) → **▼** (twice) → **ENTER** key in LOCAL.
• MACHINE SETUP MENU will be displayed.
- 2 Press **FUNC3** (>>) twice.
- 3 Press **▲▼** to select “SPACE FEED MODE”, and press the **ENTER** key.
- 4 Press **▲▼** to select a set value, and press the **ENTER** key.
INTERMITTENT : Perform intermittent feed operation of the path division unit
CONTINUOUS : Feed the no data part at a time
- 5 Press the **END/POWER** key several times to end the setting.

Set the network

You can also perform network setting with “Network Configurator”, the tool to perform network setting of Mimaki’s product. To download the Network Configurator, check “Driver / Utility” on the download page at Mimaki Engineering (<http://mimaki.com/download/>).

- 1** Press **FUNC1** (MENU) **▶** **▼** (twice) **▶** **ENTER** in LOCAL.
 - MACHINE SETUP MENU will be displayed.
 - 2** Press **FUNC3** (>>) twice.
 - 3** Press **▲** **▼** to select “NETWORK”, and press the **ENTER** key.
 - 4** Press the **ENTER** key.
 - “CHECK IP ADDRESS” will be selected.
 - The IP address currently used by this machine is displayed.
 - When you have finished the check, press the [ENTER] key.
-  • After connecting with the network, it takes time until the IP address is determined. If the IP address has not been determined, “0.0.0.0” is displayed.
- 5** Press **▼**, and press the **ENTER** key.
 - “CHECK MAC ADDRESS” will be selected.
 - The MAC address currently used by this machine is displayed.
 - When you have finished the check, press the [ENTER] key.
 - 6** Press **▼**, and press the **ENTER** key.
 - “DHCP” will be selected.
 - 7** Press **▲** **▼** to select a set value, and press the **ENTER** key.
 - **Set value:** ON/ OFF
 - When it is ON, the IP address given by the DHCP server is used.
 - 8** Press **▼**, and press the **ENTER** key.
 - “AutoIP” will be selected.
 - 9** Press **▲** **▼** to select a set value, and press the **ENTER** key.
 - **Set value:** ON/ OFF
 - When it is ON, the IP address is determined by the AutoIP protocol. However, DHCP is ON, DHCP has priority.
 - 10** Press **▼**, and press **ENTER**.
 - “IP ADDRESS” will be selected.
 - 11** Press **▲** **▼** to select a set value, and press the **ENTER** key.
 - **Set value:** ON/ OFF
 - Both of DHCP and AutoIP is OFF, you can set IP Address. For other than above, proceed to the Step 14.

- 12** Press **FUNC3**.
 - The setting items DEFAULT GATEWAY, DNS ADDRESS and SUBNET MASK will be displayed.
 - Both of DHCP and AutoIP is OFF, you can set DEFAULT GATEWAY/ DNS ADDRESS/ SUBNET MASK. For other than above, proceed to the Step 14.
- 13** Press **▼** several times to select setting item, and press the **ENTER** key.
- 14** Press **▲** **▼** to select a set value, and press the **ENTER** key.
- 15** Press the **END/POWER** key several times to end the setting.



- To reflect network setting, once turn off the power supply and turn it on again.

Setting event mail function

Set the function to send e-mails to the set e-mail address when events such as cutting start/ end and stop due to an error.



You can also perform network setting with “Network Configurator”, the tool to perform network setting of Mimaki’s product. To download the Network Configurator, check “Driver / Utility” on the download page at Mimaki Engineering (<http://mimaki.com/download/>).

- Disclaimer
- The customer is responsible for the communication fee for Internet communication such as e-mail notification.
- The notification by the event mail function may not be delivered due to Internet environment, failure of the device/ the power supply, etc. Mimaki has absolutely no responsibility for any damages or loss resulting from non-delivery or delays.

- Important!**
- You can use event mail function by connecting LAN to this machine. Please prepare for LAN cable connection beforehand.
 - Not compatible with SSL communication.

Enable the event mail function

- 1** Press **FUNC1** (MENU) **▶** **▼** (twice) **▶** **ENTER** in LOCAL.
 - MACHINE SETUP MENU will be displayed.
- 2** Press **FUNC1** (<<).
- 3** Press **▲** **▼** to select “EVENT MAIL”, and press the **ENTER** key.
- 4** Press the **ENTER** key.
 - “MAIL DELIVERY” will be selected.

5 Press   to select "ON", and press the  key.



6 Press the  key several times to end the setting.





Set the event to send an event mail

1 Press  (MENU)   (twice)  in LOCAL.
• MACHINE SETUP MENU will be displayed.

2 Press  (<<).

3 Press   to select "EVENT MAIL", and press the  key.

4 Press , and press the  key.
• "SELECT EVENT" will be selected.

5 Press   to select the event, and press  (✓).
• After selecting the event, press [FUNC2] key and put a check in the check box.
An email will be sent when the event whose box has been checked occurs.
• To select multiple events, use [][] to put the cursor over the events you want, and put a check in their boxes by pressing [FUNC2].

Event name	Outline
PRINT START	Sets sending/not sending of an email when printing starts.
PRINT END	Sets sending/not sending of an email when printing ends.
ERROR	Sets sending/not sending of an email when printing is stopped due to occurrence of an error.
WARNING	Sets sending/not sending of an email when a warning occurs during printing.
etc.	Sets sending/not sending of an email when an event other than the above occurs.



6 Press the  key several times to end the setting.

Set the e-mail address

1 Press  (MENU)   (twice)  in LOCAL.
• MACHINE SETUP MENU will be displayed.

2 Press  (<<).

3 Press   to select "EVENT MAIL", and press the  key.

4 Press  twice, and press the  key.

• "MAIL ADDRESS" will be selected.

5 Press     to set mail address, and press the  key.

• Set the e-mail address to which you send the event mail.
• Set it with alphanumeric characters and symbols within 96 characters.



6 Press the  key several times to end the setting.





Set the subject

1 Press  (MENU)   (twice)  in LOCAL.
• MACHINE SETUP MENU will be displayed.

2 Press  (<<).

3 Press   to select "EVENT MAIL", and press the  key.

4 Press  3 times, and press the  key.
• "MESSAGE SUBJECT" will be selected.

5 Press     to set subject, and press the  key.
• Set the characters to write in the subject of the event mail.
• Set it with alphanumeric characters and symbols within 8 characters.

6 Press the  key several times to end the setting.

Set the server

- 1 Press **FUNC1** (MENU) **▶** **▼** (twice) **▶** **ENTER** in LOCAL.
 - MACHINE SETUP MENU will be displayed.
- 2 Press **FUNC1** (<<).
- 3 Press **▲** **▼** to select “EVENT MAIL”, and press the **ENTER** key.
- 4 Press **▼** 4 times, and press the **ENTER** key.
 - “SERVER SETUP” will be selected.
- 5 Press the **ENTER** key.
 - “SMTP ADDRESS” will be selected.
- 6 Press **▲** **▼** **◀** **▶** to set SMTP Address, and press the **ENTER** key.
 - Press jog key [**▲**][**▼**][**◀**][**▶**] to set SMTP address.
 - Input the SMTP address name.
- 7 Press **▼**, and press the **ENTER** key.
 - “SMTP PORT No.” will be selected.
- 8 Press **▲** **▼** to set SMTP Port No., and press the **ENTER** key.
 - Set the SMTP port number.
- 9 Press **▼**, and press the **ENTER** key.
 - “SENDER ADDRESS” will be selected.
- 10 Press **▲** **▼** **◀** **▶** to set SENDER ADDRESS, and press the **ENTER** key.
 - Press [**▲**][**▼**][**◀**][**▶**] and set the e-mail address to be used as the sender mail address.
 - Set it with alphanumeric characters and symbols within 64 characters.

 - Depending on your server, if you do not set the e-mail address not supporting the account, sending/ receiving e-mails may be unavailable.
- 11 Press **▼**, and press the **ENTER** key.
 - “AUTHENTICATION” will be selected.
- 12 Press **▲** **▼** to set authentication method, and press the **ENTER** key.
 - Set the authentication method of the SMTP server.
 - When you select [OFF], proceed to the Step 20.
- 13 Press **▼**, and press the **ENTER** key.
 - “USER NAME” will be selected.
- 14 Press **▲** **▼** **◀** **▶** to set User Name, and press the **ENTER** key.
 - Press [**▲**][**▼**][**◀**][**▶**] to set the user name to use for the authentication.
 - Set it with alphanumeric characters and symbols within 30 characters.
- 15 Press **▼**, and press the **ENTER** key.
 - “PASSWORD” will be selected.
- 16 Press **▲** **▼** **◀** **▶** to set Password, and press the **ENTER** key.
 - Press [**▲**][**▼**][**◀**][**▶**] to set the password to use for the authentication.
 - Set it with alphanumeric characters and symbols within 15 characters.



 - On the password setting screen, you can only check the value that you are currently inputting.

 - When you select [POP before SMTP] in the Step 11, set the items in the Step 16 to 19.
- 17 Press **▼**, and press the **ENTER** key.
 - “POP3 ADDRESS” will be selected.
- 18 Press **▲** **▼** **◀** **▶** to set POP3 Address, and press the **ENTER** key.
 - Press [**▲**][**▼**][**◀**][**▶**] to set POP server.
 - Input the POP server name.
- 19 Press **▼**, and press the **ENTER** key.
 - “APOPOP” will be selected.
- 20 Press **▲** **▼** to set ON/ OFF, and press the **ENTER** key.
- 21 Press the **END/POWER** key several times to end the setting.

Send a test e-mail

- 1** Press **FUNC1** (MENU) → **▼** (twice) → **ENTER** in LOCAL.
 - MACHINE SETUP MENU will be displayed.
- 2** Press **FUNC1** (<<).
- 3** Press **▲▼** to select “EVENT MAIL”, and press the **ENTER** key.
- 4** Press **FUNC3** (>>) → **ENTER** .
 - “TRANSMIT TEST” will be selected.

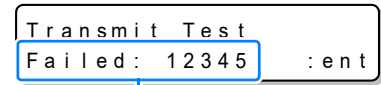
- 5** Press the **ENTER** key.
 - The sent result is displayed.
 - If sending test e-mail has failed, an error code is displayed.
Refer to the next page to solve the problem.



- 6** Press the **END/POWER** key several times to end the setting.



- The sent result of the test e-mail is the result of e-mail sending process performed by this machine to the e-mail server. It does not indicate that the e-mail was received at the address.
- If the spam e-mail filter etc. has been set in the terminal in which e-mails are received, even if “Sending has been completed” is displayed, the e-mail cannot be received in some cases.
- If sending test e-mail has failed, the error code below is displayed.
- If the error cannot be solved, try again after a while.
- For the server setting etc., contact with the network administrator or the provider.

Error Code	The expected casus	Remedy
10	Network connection error	<ul style="list-style-type: none"> • Check that the machine is connected with the network. • Check that the machine IP address is correct. • Check that the machine is in the environment where DNS is available.
20	No valid e-mail address.	<ul style="list-style-type: none"> • Enter the correct e-mail address.
11003 11004	The POP server cannot be found. Or cannot access DNS server.	<ul style="list-style-type: none"> • Check the POP server address. • Check that the machine is in the environment where DNS is available.
11021	Cannot connect with the POP server.	<ul style="list-style-type: none"> • Check the POP server setting. • Check the firewall setting.
12010	An error returns from the POP server.	<ul style="list-style-type: none"> • Check the POP server setting.
13000	The POP authentication has failed.	<ul style="list-style-type: none"> • Check the user name and the password. • Check the APOP setting. • Confirm the authentication method.
10013 10014	The SMTP server cannot be found. Or cannot access DNS server.	<ul style="list-style-type: none"> • Check the SMTP server address. • Check that the machine is in the environment where DNS is available.
10021	Cannot connect with the SMTP server.	<ul style="list-style-type: none"> • Check the SMTP server setting. • Check the SMTP port number. • Check the firewall setting.
10*** 11*** 20*** 21***	An error returns from the SMTP server. Or, there was no response.	<ul style="list-style-type: none"> • Check the SMTP server setting. • Cannot communicate with a server that requires mandatory SSL communication. • Check protocol filter settings.
12***	It is invalid sender address.	<ul style="list-style-type: none"> • Check that the e-mail address supporting the account entered in the user name/ the password is set in SENDER ADDRESS.
13***	The e-mail address cannot be found. Or, it is invalid sender address.	<ul style="list-style-type: none"> • Check the e-mail address. • Even if there is a mistake in the e-mail address, this error cannot be detected in some cases. • Check that the e-mail address supporting the account entered in the user name/ the password is set in SENDER ADDRESS.
22000 22008	SMTP authentication error	<ul style="list-style-type: none"> • Confirm the authentication method.
23*** 24*** 25***	The SMTP authentication has failed.	<ul style="list-style-type: none"> • Check the user name and the password.

“***” is the error code returned from the e-mail server.

Initializing the Settings

You can return the setting of “SETUP”, “MAINTENANCE” and “MACHINE SETUP” to the status before shipment.

- 1** Press **FUNC1 (MENU)** → **▼** (twice) → **ENTER** in **LOCAL**.
 - MACHINE SETUP MENU will be displayed.
- 2** Press **FUNC1 (<<)**.
- 3** Press **▲** **▼** to select “RESET”, and press the **ENTER** key.
- 4** Press the **ENTER** key.
 - The already configured settings are initialized.
- 5** Press the **END/POWER** key several times to end the setting.

About NOZZLE CHECK MENU

Set operations concerning the nozzle missing detection function.

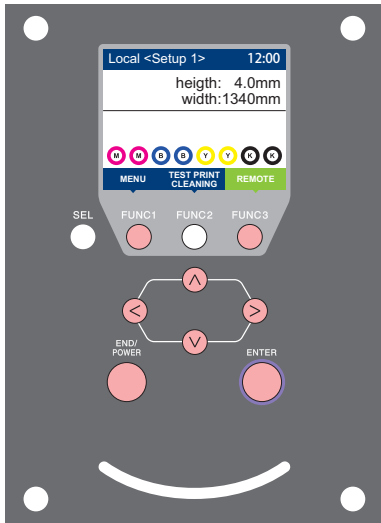

- FUNC1** : Press this to select INFORMATION MENU, or to switch to the previous screen.
- FUNC3** : Press this to switch to the next screen.
- ▲ ▼** : Use these to select a setting item.
- ENTER** : Press this to confirm a setting, etc..

◆ NOZZLE CHECK MENUs at-a-glance

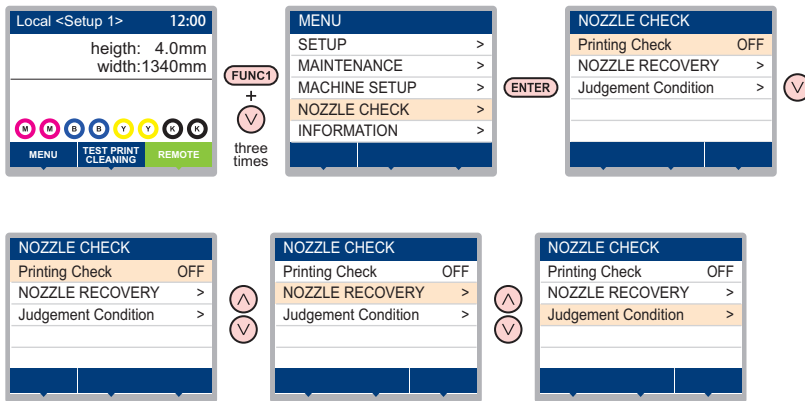

INFORMATION MENU table

Function name		Set value	Default	Meaning	
(ON)	Printing Check (☞ P.3-25)	ON/OFF	OFF	Set this when you want to conduct nozzle check at the beginning of online printing.	
	Check Interval	LENGTH	0.1 to 50.0m	30.0 m	Conducts nozzle check at each set length.
		FILE	1 to 100	30 file	Conducts nozzle check at each set number of files. *1
	Action	CLEANING	OFF/ SOFT/ NORMAL/ HARD	SOFT	Sets the type of cleaning performed during recovery work.
RETRY COUNT		0 to 3	0	Repeats the retry operation for the set number of times.	
NOZZLE RECOVERY (☞ P.3-26)		ON/OFF	OFF	Set this when you want to conduct automatic nozzle recovery.	
Judgement Condition (☞ P.3-26)		1 to 200	1	Sets how many missing nozzles are detected for "Nozzle Missing" judgment to be made according to each color. (Maximum 16 per 1 nozzle line)*2	

*1. When the set length is reached during printing, nozzle check is conducted at the start of the next printing.

*2. Depending on the print conditions, nozzle recovery is not applied in some cases.

Printing Check Flow

Nozzle check is conducted according to the following flow at the start of printing.



- Turn the “Printing Check” setting ON to be enabled.
- Only perform RETRY COUNT and Printing Check settings when the settings are enabled.

1 nozzle check → Judgment

Detects missing nozzles.

2 Recovery operation → nozzle check → Judgment

If more missing nozzles than “Judgement Condition” are detected after the nozzle check, cleaning is performed and nozzle check is conducted again.

3 Retry → Judgment

If more missing nozzles than “Judgement Condition” are detected after the recovery operation, the recovery operation is conducted again.

4 Printing Check → Judgment

Nozzle recovery is automatically conducted following nozzle check and recovery operation.

- Turn the “Printing Check” setting ON to be enabled.

5 Nozzle Missing judgment

If more missing nozzles than A are eventually detected, continued printing will be deemed impossible and printing will stop.

Printing Operations at “Nozzle Missing” Judgment and Error Occurrence

- When judged to be “Nozzle Missing” → Printing is stopped.
- When error occurs during nozzle check → Printing is stopped and “Printing Check” is automatically turned OFF. After recovering from the error, set “Printing Check” once again.

Setting the Printing Check

Select ON when you want to conduct nozzle check at the start of online printing.

- 1 Press **FUNC1** (MENU) \rightarrow \downarrow (3 times) \rightarrow **ENTER** in LOCAL.
 - NOZZLE CHECK MENU will be displayed.
- 2 Press the **ENTER** key.
 - “Printing Check” will be selected.
- 3 Press \uparrow \downarrow to select ON, and press the **ENTER** key.
 - The “Check Interval” setting screen will be displayed.
 - “Select OFF to not set nozzle check. Proceed to Step 11.
- 4 Press the **ENTER** key.
- 5 Press \uparrow \downarrow to select setting item, and press the **ENTER** key.
 - select the nozzle check interval from “LENGTH” or “FILE”.
 - LENGTH** : nozzle check is conducted when the printed length reaches the set length.
 - FILE** : nozzle check is conducted when the number of printed files reaches the set number.
- 6 Press \uparrow \downarrow to select setting value, and press the **ENTER** key.
 - The set value will differ according to the setting selected in Step 5.
 - LENGTH** : 0.1 to 50.0 m
 - FILE** : 1 to 100 files
- 7 Press the **ENTER** key twice.
 - The “Action” setting screen will be displayed.
- 8 Press the **ENTER** key.
 - “CLEANING TYPE” will be selected.
- 9 Press \uparrow \downarrow to select cleaning type, and press the **ENTER** key.
 - Setting value : OFF/SOFT/ NORMAL/ HARD
- 10 Press \uparrow \downarrow to select retry count, and press **ENTER** .
 - Setting value : 0 to 3
- 11 Press the **END/POWER** key several times to end the setting.

Setting the NOZZLE RECOVERY

set this if you want to conduct automatic nozzle recovery when nozzle missing is detected.

- 1 Press **FUNC1** (MENU) \rightarrow \downarrow (3 times) \rightarrow **ENTER** in LOCAL.
 - NOZZLE CHECK MENU will be displayed.
- 2 Press \downarrow , and press the **ENTER** key.
 - “NOZZLE RECOVERY” will be selected.
- 3 Press \uparrow \downarrow to select ON/OFF, and press **ENTER** .
- 4 Press the **END/POWER** key several times to end the setting.

Setting the Judgement Condition

Set the conditions for judging nozzle missing.

- 1 Press **FUNC1** (MENU) \rightarrow \downarrow (3 times) \rightarrow **ENTER** in LOCAL.
 - NOZZLE CHECK MENU will be displayed.
- 2 Press \downarrow twice, and press the **ENTER** key.
 - “Judgement Condition” will be selected.
- 3 Press \uparrow \downarrow to select color, and press the **ENTER** key.
 - 
 - The type of color changes depending on the ink set.
- 4 Press \uparrow \downarrow to set the number of nozzles for judgment, and press the **ENTER** key.
- 5 Press the **END/POWER** key several times to end the setting.

About INFORMATION MENU

The information of this machine can be confirmed.
The following items can be confirmed as machine information.

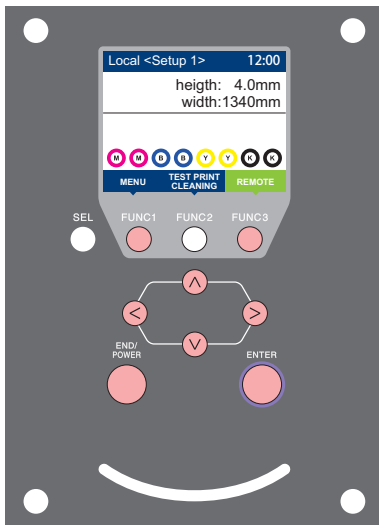

FUNC1 : Press this to select INFORMATION MENU, or to switch to the previous screen.

FUNC3 : Press this to switch to the next screen.

▲ ▼ : Use these to select a setting item.

ENTER : Press this to confirm a setting, etc..

◆ INFORMATION MENUs at-a-glance

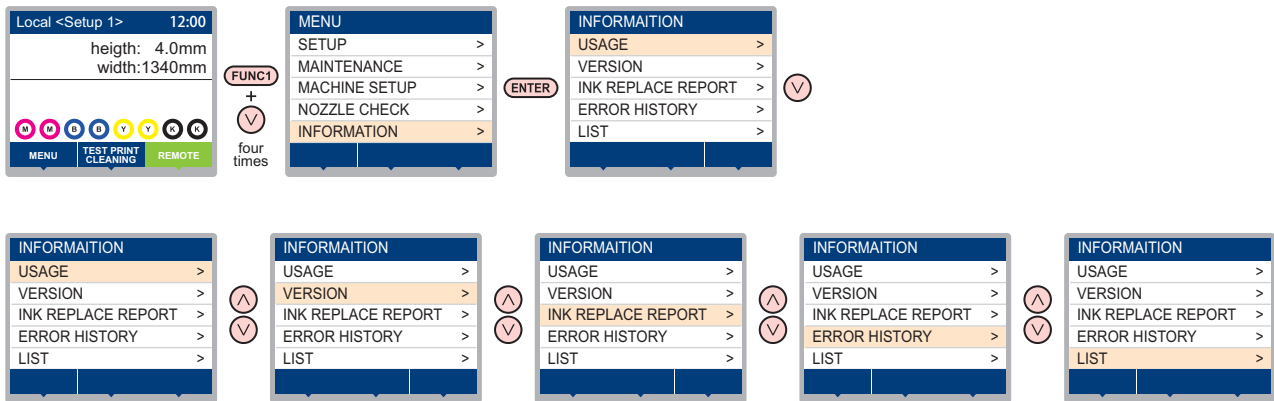

INFORMATION MENU table

Item	Description	
USAGE	WIPING	This displays how many wipings have been done.
	WASTE TANK	This displays how much waste ink has built up in the waste ink tank, as a rough percentage of the tank capacity.
	PRINT LENGTH	This displays the total length of the printing done to date.
	PRINT AREA	This displays the total area of the printing done to date.
	USE TIME	This displays the total time for which the printer has been used to date.
	Spout Rubber	This displays the total time for which Spout Rubber has been used.
	Adhesive	This displays adhesive usage length.
Absorb Roller	This displays absorb roller usage length.	
VERSION	This displays the version information of this machine.	
Ink REPL. Report	This prints ink history of this machine.	
ERROR HISTORY	This displays the history of errors and warnings to date. When you press [▲][▼], the date of occurrence (year/month/day/hour/minute) and the error/warning information are displayed alternately in the order of occurrence.	
LIST	This allows you to print the settings of this machine.	

Displaying the Information

- 1 Press **FUNC1 (MENU)** → **▼** (4 times) → **ENTER** in LOCAL.
 - INFORMATION MENU will be displayed.
- 2 Press **▲▼** to select a information.
 - Refer to the "INFORMATION MENU", and select the information to be displayed.
- 3 Press the **ENTER** key.
 - If you selected [LIST] in step 2, the machine's settings will be printed.
- 4 Press the **END/POWER** key several times to end the setting.



- When you reset the used count of the wiper, press [FUNC2] key while [RESET?] is displayed. When you press the [ENTER] key, the number of wipings is reset.
- By pressing the function key during display of "WIPING information", "WASTE TANK information", "Spout Rubber", "Adhesive" and "Absorb Roller" in USAGE, the used counts can be reset.
 - When resetting WIPING information** : Press [FUNC2]
 - When resetting WASTE TANK information** : Press [FUNC1]
 - When resetting Spout Rubber** : Press [FUNC3]
- To reset "Adhesive" and "Absorb Roller" in usage status, perform "COUNTER RESET" (☞ P.4-33).

Chapter 4

Maintenance



This chapter

describes the items required to use this machine more comfortably, which are the methods for the daily care, the maintenance of the ink cartridges etc.

Maintenance	4-2	Setting the Refreshing Intervals	4-16
Precautions for Maintenance	4-2	Setting the Tube Wash Intervals	4-17
About Cleaning Solution.....	4-2	Setting the Cleaning Intervals and Type	4-17
Cleaning the Exterior Surfaces	4-2	Suspend the nozzle cleaning.....	4-17
Cleaning the peeling roller	4-2	Fill up Ink	4-18
Cleaning the Belt Correction Unit	4-3	Replacing consumables	4-18
About MAINTENANCE MENU	4-4	Replacing the wiper	4-18
MAINTENANCE MENUs at-a-glance	4-5	Replacing the Spout Rubber	4-19
Maintaining the Capping Station	4-6	If a Waste Ink Tank Confirmation Message Ap- pears	4-21
Cleaning the Wiper and Cap	4-6	Replace the waste ink tank with another ...	4-21
Washing the Head Nozzle	4-7	Replacing the Water	4-22
Washing the Ink Discharge Passage	4-9	Wash Unit Maintenance	4-23
When the Machine Is Not Used for a Long Time 4-10		Cleaning the Belt Wash Unit	4-23
Cleaning the Ink Head and the Area around It 4- 13		Absorb Roller Cleaning	4-24
Nozzle Recovery Function	4-14	Reapplying Adhesive	4-26
Reset the set value	4-15	Peeling Off Adhesive	4-26
Check the condition for which nozzle recovery cannot be performed	4-15	Applying Adhesive	4-28
Enabling or disabling nozzle recovery during a test print	4-16	Cleaning the washing tray and brush	4-31
Automatic Maintenance Function	4-16	Feeding Belt Cleaning	4-32
		Peeling Sensor Cleaning	4-33
		Resetting the Counter	4-33

Maintenance

Maintain the machine regularly or as necessary so that its accuracy will be maintained and it can continue to be used for a long time.

Precautions for Maintenance

Pay attention to the following items when maintaining this machine.

	<ul style="list-style-type: none"> When using cleaning solution for maintenance, be sure to wear the supplied protective glasses.
	<ul style="list-style-type: none"> Never disassemble the machine. Disassembling it can result in electric shock hazards or damage to the machine. Before maintenance, be sure to turn off the power switch and unplug the power cable; otherwise, an unexpected accident may occur.
	<ul style="list-style-type: none"> Prevent moisture from entering the machine. Moisture inside the machine can cause electric shock hazards or damage to the machine.
	<ul style="list-style-type: none"> To ensure stable ink jetting, it is necessary for the machine to eject a small amount of ink (flushing) regularly when a printing (outputting) operation has not been performed for a long time. When the machine is not to be used for a long time, turn off only the power switch on the front side, leave the main power switch at the right side turned ON (in the position of I), and leave the power cable connected.
	<ul style="list-style-type: none"> Do not wipe the nozzle face of the heads, wiper, caps, etc. with water or alcohol. Doing so can cause nozzle clogging or machine failure. Do not use benzene, thinner, or any chemical agent containing an abrasive. Such materials can deteriorate or deform the surface of the cover. Do not apply a lubricant, etc. to any parts inside the machine. Doing so can cause printing failure. Be careful that the cleaning solution, ink, etc. not to stick to the cover because this may cause the surface of the cover to deteriorate or deform.

About Cleaning Solution

Use the cleaning liquid dedicated for the ink being used.

Type of Ink	Applicable maintenance washings
Sublimation dye ink: Sb420 Sublimation dye ink: Sb421 Disperse dye ink: Dd400 Acid-dye ink: Ac400 Reactive-dye ink: Rc400 Reactive-dye ink: Rc500	Cleaning Liquid 03 MAINTENANCE KIT (ML003-2-K1) [Sold separately]
Pigment ink for textile: TP400	C-MLO12-Z-K1-1-KW
Hybrid ink: Sb420 + Dd400 Hybrid ink: Sb421 + Dd400	

Cleaning the Exterior Surfaces

When the exterior surfaces of the machine are stained, dampen a soft cloth with water or a neutral detergent diluted with water, squeeze it, and wipe the surfaces with the cloth.

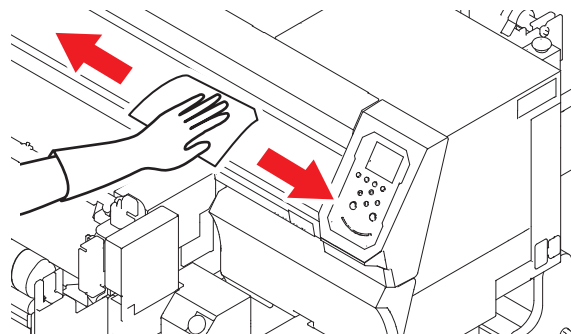

Cleaning the peeling roller

Remove ink stain etc. adhering to the peeling roller at the front side of the machine.

Moisten soft cloth with water or waterish mild detergent, squeeze tightly and then wipe it off.

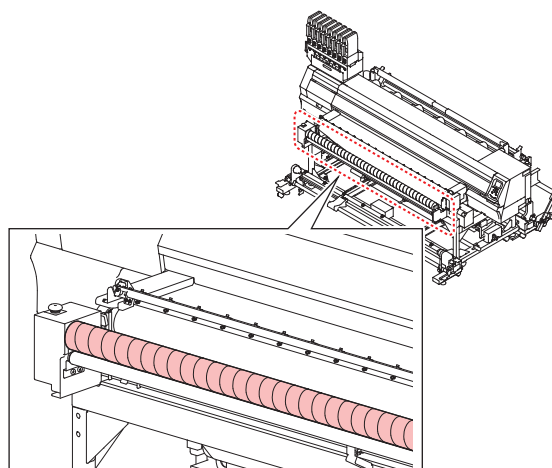

Cleaning the Belt Correction Unit

An adhesive painted on the feeding belt may attach to the grip rubber of belt correction unit.

When keeping an adhesive attaching on the grip rubber, it becomes the cause that the belt correction unit skids and the print quality decreases.

Clean the grip rubber of belt correction unit and the 20 mm width from the edge (all laps on the right side) of the feeding belt regularly. (one time per a week)

1 Clean the edge of the feeding belt.

- Wipe the 20 mm width from the edge of the feeding belt with an alcohol soaked waste cloth.

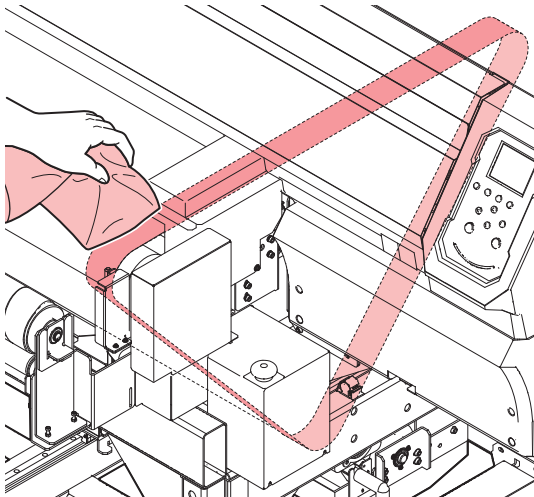

- Make sure to stop the machine when doing the cleaning. (to avoid being rolled up)

2 Press to feed the belt.

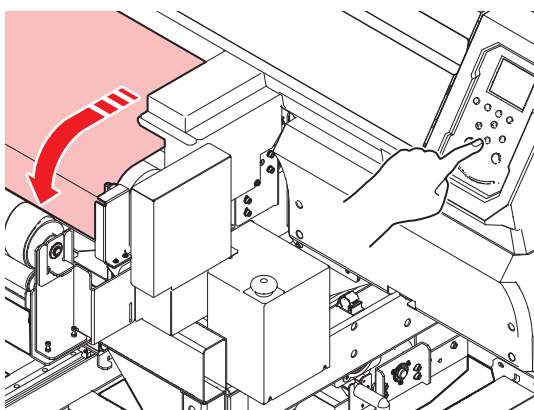

3 Repeat the step 1 and 2 to clean all around.

4 Remove the cover of belt correction unit.



- To avoid being rolled up, make sure to turn off the power when working.

5 Clean the grip rubber.

- Wipe the grip rubber part at the top and bottom of the feeding belt with an alcohol soaked cotton swab.

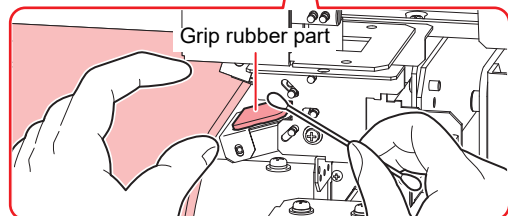
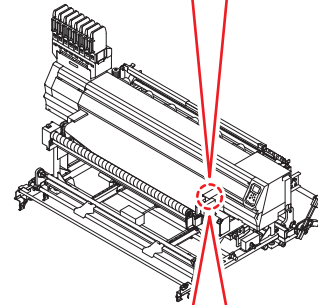
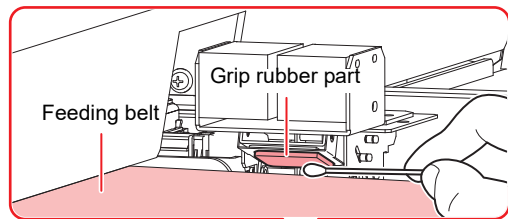

6 Attach the cover of belt correction unit.



- To avoid being rolled up, make sure to turn off the power when working.

About MAINTENANCE MENU

This provides various settings for doing maintenance on the machine.
The following items can be set in Maintenance settings.

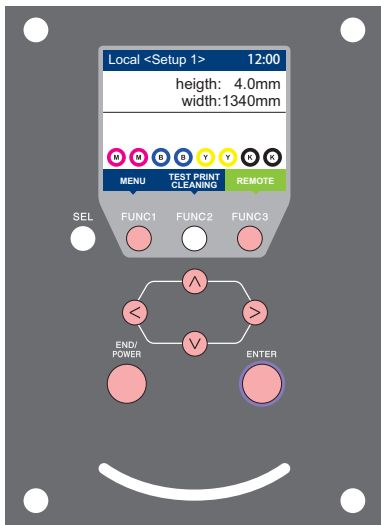

- FUNC1** : Press this to select MAINTENANCE MENU, or to switch to the previous screen.
- FUNC2** : Press this to use the maintenance function.
- FUNC3** : Press this to switch to the next screen.
- ▲ ▼** : Use these to select a setting item.
- ENTER** : Press this to confirm a setting, etc..

◆ MAINTENANCE MENUs at-a-glance

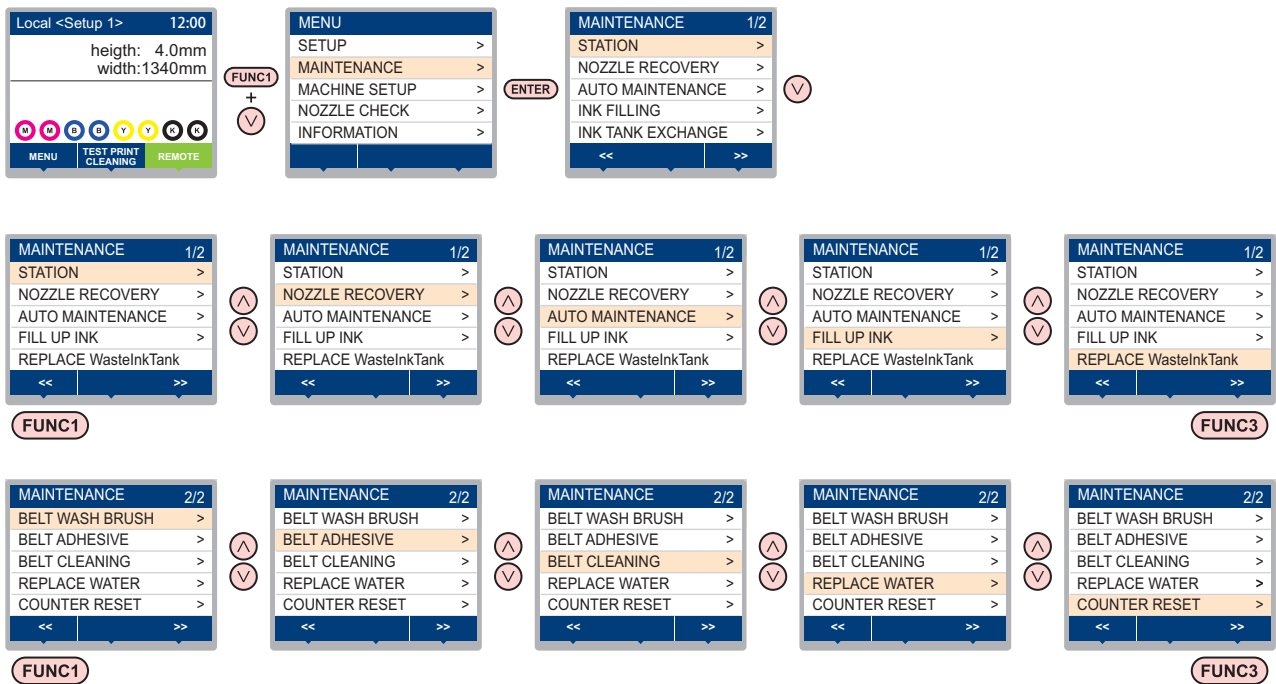

◆ Screen transition when **FUNC2** is pressed

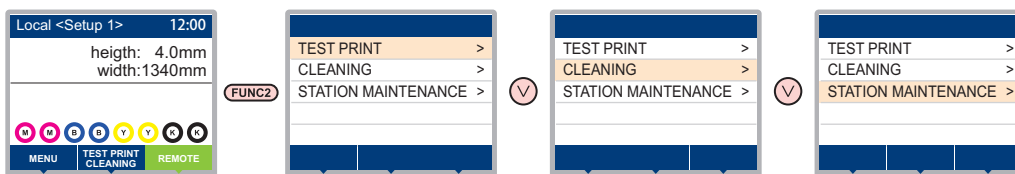

MAINTENANCE MENUs at-a-glance

Item		Set value	Meaning
STATION MAINTENANCE	For carrying out maintenance on the carriage and station periphery.		
	CARRIAGE OUT (☞ P.4-6)	_____	Moves the carriage out, for carrying out cleaning of the cap periphery, head, wipers, etc.
	NOZZLE WASH (☞ P.4-7)	1 to 99min	Soaks the nozzle surfaces in maintenance cleaning fluid, for carrying out recovery from nozzle clogging or bent.
	DISWAY WASH (☞ P.4-9)	_____	Executes washing of the suction pump tubes.
	CUSTODY WASH (☞ P.4-10)	1 to 99min	Carried out when the machine is going to be out of use for an extended period. Washes the nozzles and tubes beforehand, to keep the machine in fine condition.
	WIPER EXCHANGE (☞ P.4-18)		Used when replacing the wiper. If the wiper is replaced, the number of times the wiper was used that is managed in this device is reset.
NOZZLE RECOVERY (☞ P.4-14)	For printing using another nozzle, if nozzle wash and so forth fail to effect recovery from nozzle missing, etc.		
	PRINT		Used to print a pattern and to check and/or register clogged nozzles.
	ENTRY		Registers the faulty nozzle identified by "PRINT".
	RESET		Resets a registered faulty nozzle.
	CHECK		Checks recoverable printable conditions.
	TEST PRINT	ON/OFF	Enables or disables the configuration of the nozzle recovery function during a test print.
AUTO MAINT. (☞ P.4-16)	For having the various maintenance functions executed automatically. Set the execution interval for each maintenance function.		
	REFRESH	The setting is different depending on your ink type.	For setting the activation interval for refresh.
	PUMP TUBE CLEANING		For setting the activation interval for the ink discharge passage cleaning.
	CLEANING	INTERVAL	For setting the activation interval for the head cleaning.
TYPE		NORMAL/ HARD*1	Select the cleaning type for head cleaning.
FILL UP INK (☞ P.4-18)	Supplies ink to correct nozzle clogging.		
REPLACE WastelInkTank (☞ P.4-21)	Resets or corrects the used count for the waste ink tank.		
BELT WASH UNIT (☞ P.4-23)	Move the belt wash unit to the maintenance position and clean the washing belt and the inside of tray.		
BELT ADHESIVE (☞ P.4-26)	Peel off adhesive	Peel off the adhesive.	
	Applying Adhesive	Apply the adhesive.	
BELT CLEANING (☞ P.4-32)	Used to clean feeding belt.		
REPLACE WATER (☞ P.4-22)	DRAIN	Drains water from the wash unit.	
	SUPPLY	Supplies water to the wash unit.	
	CLEANING WASH TRAY	Clean the washing tray and the washing brush.	
COUNTER RESET (☞ P.4-33)	Adhesive	Initializes the counter settings.	
	Absorb Roller		

*1. "Soft" can also be set when reactive dye ink Rc 400 or Rc 500 is used.

Maintaining the Capping Station

Maintain the ink cap, wiper, etc. located in the capping station. (SATION MAINT.)

- Important!**
- To keep the nozzle status normal, perform wiper cleaning frequently.

The ink cap and wiper function as follows.

- Wiper** : It wipes off ink sticking to the head nozzles.
- Ink cap** : It prevents the head nozzles from clogging due to dryness.

As the machine is used repeatedly, the wiper and ink cap gradually become dirty with ink, dust, etc.

If nozzle missing cannot be corrected even after head cleaning (P.2-27) has been performed, use a Cleaning Liquid 03 MAINTENANCE KIT and clean stick.

Tools required for Maintenance

- Cleaning Liquid 03 MAINTENANCE KIT (ML003-Z-K1)
- Clean stick (SPC-0527)
- Gloves
- Safety glasses



- Be sure to wear the included safety glasses and gloves when maintaining the capping station. Otherwise, you may get ink in your eyes.
- Do not move the carriage out of the capping station by hand. When it is desirable to move the carriage, press [FUNC1] key to execute the carriage-out. (P.4-6 Steps 1 to 2)

Cleaning the Wiper and Cap

It is recommended that the wiper and cap be cleaned frequently in order to maintain the high image quality of the machine and keep the machine itself in good working order.

- Important!**
- Replace the wiper with a new one when it is extremely dirty or bent. (P.4-18)
 - When cleaning the wiper, be careful that lint from the clean stick does not get left on the wiper. Remaining lint may cause image quality to deteriorate.

1 Press **FUNC1 (MENU)** → **ENTER** in **LOCAL**.

- MAINTENANCE MENU will be displayed.

2 Press the **ENTER** key twice.

- The carriage moves onto the belt.

3 Open the front cover.

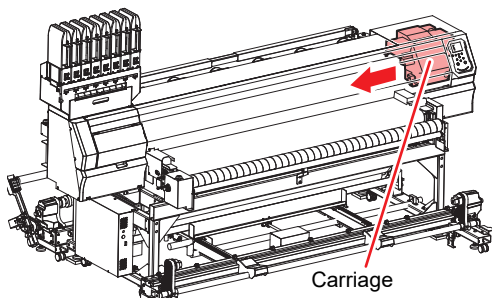

4 Remove the wiper.

- Pull out the wiper by holding the protrusions at its both ends.

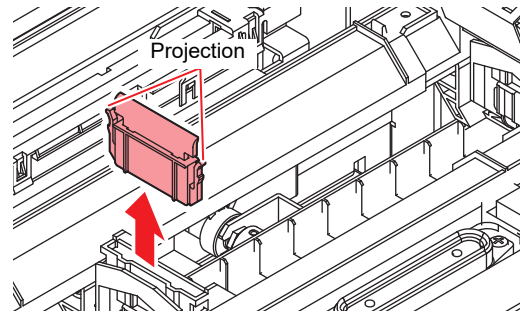

5 Clean the wiper and bracket.

- Wipe off the ink sticking to the wiper and bracket with a clean stick dipped in cleaning solution for maintenance. Wipe off so that cleaning solution for maintenance will not remain.

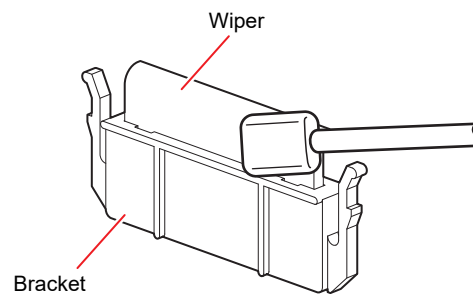

6 Clean the wiper cleaner.

- Wipe off the ink sticking to the wiper cleaner with a clean stick dipped in cleaning solution for maintenance. Wipe off so that cleaning solution for maintenance will not remain.

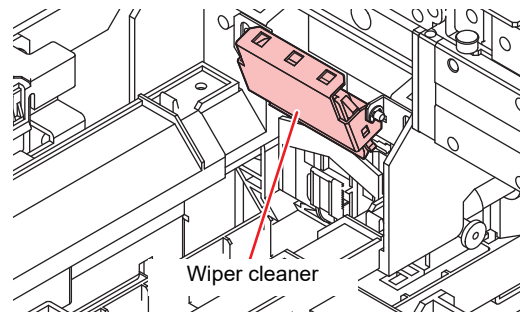

- If there is a large amount of ink in the absorbent case, wipe it away using water-absorbent paper or the like.

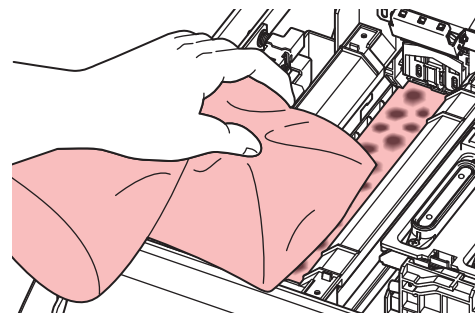



- Do not remove the wiper cleaner from the bracket.
- Only clean the front surface on the wiper cleaner's wiper. (You do not need to clean the rear surface.)
- Do not remove the absorbent material in the absorbent case.
- After the wiper cleaner cleaning, make sure that the cleaner is not facing up.

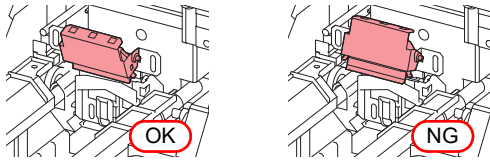

7 Set the wiper at the original position.

- Insert the wiper by holding the protrusions at its both ends.

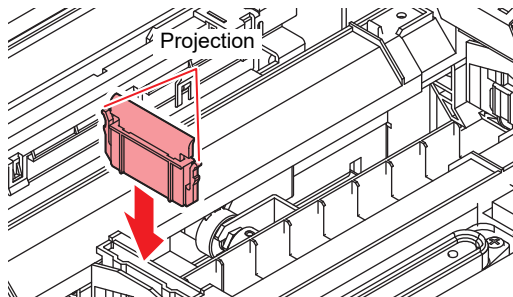

8 Clean the cap rubber.

- Wipe off the ink sticking to the cap rubber with a clean stick dipped in maintenance solution for maintenance.
- Wipe off so that maintenance solution for maintenance will not remain.

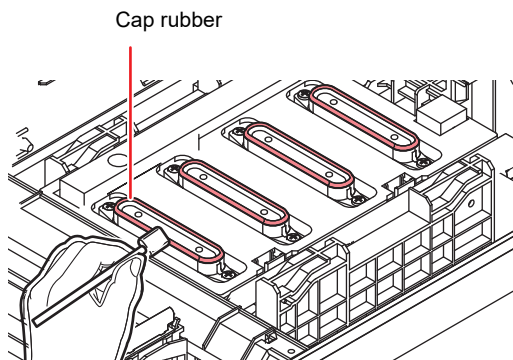

Important!

- After cleaning the cap rubber, check to make sure the cap slider is not tilted.
- If it is tilted, move the slider block left and right to fix its tilt.

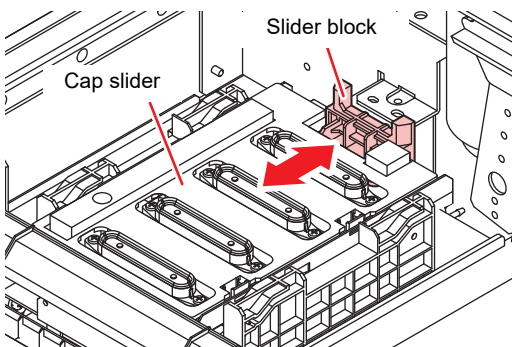

9 Press the **ENTER** key after the cleaning.

10 Close the front cover then press the **ENTER** key.

- After its initial operation, the machine returns to step1.

Washing the Head Nozzle

1 Press **FUNC1** (MENU) → **ENTER** in LOCAL.

- MAINTENANCE MENU will be displayed.

2 Press **ENTER**.

- "STATION" will be selected.

3 Press **▲** **▼** to select "NOZZLE WASH", and press the **ENTER** key.

4 Press **▲** **▼** to select the washing head, and press the **ENTER** key.

5 When "WIPER CLEANING" appears on the display, open the front cover.

6 Clean the wiper and the bracket, and press the **ENTER** key.

- (1) Open the right maintenance cover then pull out it by holding projections at both ends of the wiper.
- (2) Clean the wiper and bracket with a clean stick dipped in maintenance washing liquid for maintenance.
 - Wipe off so that maintenance washing liquid for maintenance will not remain.
- (3) Insert it in the original position by holding the projections at both ends of the wiper.

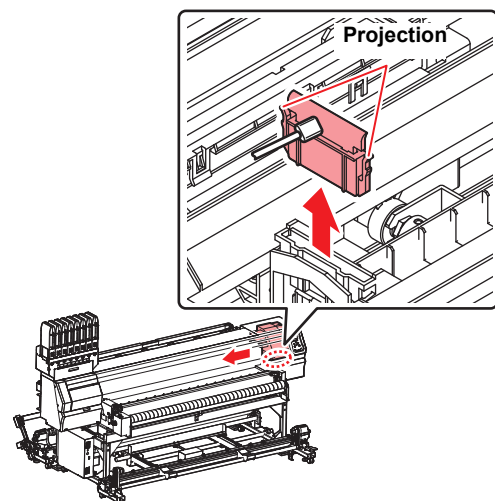

Important!

- After cleaning the wiper, check to make sure the cap slider is not tilted. If it is tilted, move the slider block left and right to fix its tilt.

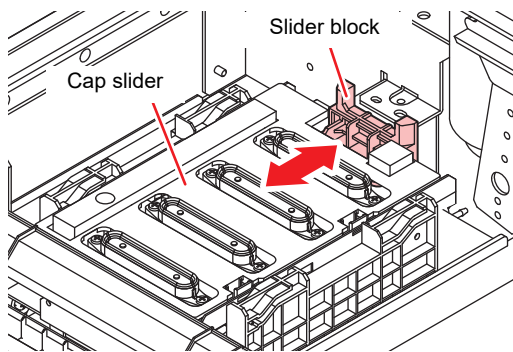

7

When cleaning of the cap rubber is complete, close the front cover and press the **ENTER key.**

- Wipe off the ink sticking to the cap rubber with a clean stick dipped in maintenance washing liquid for maintenance.
- Wipe off so that maintenance washing liquid for maintenance will not remain.
- At this time, the discharge passage is cleaned automatically.

8

Fill up the cap with cleaning solution for maintenance.

- If the cleaning solution cartridge is usable, maintenance solution is automatically filled.
- When the cap is filled with cleaning solution, the display will prompt you to check the cleaning solution.

Important!

- If the front cover is not closed, the cleaning solution will not be automatically filled. If the front cover is open, be sure to close it.



- If the cleaning cartridge is not valid, the cleaning solution will not be automatically filled to the cap. Open the front cover and use a dropper to fill the maintenance cleaning solution in the cap to just before it overflows. Once the cleaning solution is full, begin from Step 9.

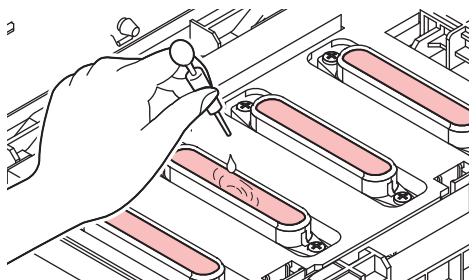

9

If a message is displayed, open the front cover and check the amount of cleaning solution in the cap.

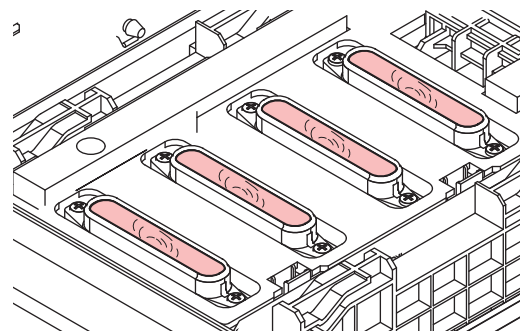

Important!

- If the solution does not fill up the cap, use a dropper to fill the maintenance cleaning solution in the cap to just before it overflows.

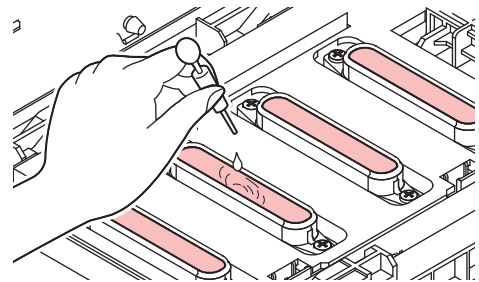

10

Close the front cover, and press the **ENTER key.**

11

Press **▲ **▼** to set the time for the maintenance washing liquid to be left as it is, and press the **ENTER** key.**

- **Set value** : 1 to 99 minutes (Unit: minute)
- The maintenance washing liquid filled in the cap is absorbed.
- "Please Wait" will be displayed in the display until the time you set has elapsed.

Important!

- When nozzle missing is not cleared even after nozzle recovery (P.4-14) or this washing is carried out several times, contact the distributor in your region or our service office.

Washing the Ink Discharge Passage

Wash the ink discharge passage regularly (about once a week) to prevent the head nozzles from clogging due to ink coagulation inside the passage.

Important!

- Before washing the ink discharge passage, make sure that the maintenance washing liquid is set. If the maintenance washing liquid is not set, washing operation will not be conducted and the passage could be clogged.

1

Press **FUNC1 (MENU)** → **ENTER** in **LOCAL**.

- MAINTENANCE MENU will be displayed.

2

Press the **ENTER** key.

- "STATION" will be selected.

3

Press **▲▼** to select "DISWAY WASH", and press the **ENTER** key.

4

Press **▲▼** to select the washing head, and press the **ENTER** key.

5

Fill up the cap with cleaning solution for maintenance.

- If the cleaning solution cartridge is usable, maintenance solution is automatically filled.

Important!

- If the front cover is not closed, the cleaning solution will not be automatically filled. If the front cover is open, be sure to close it.



- If the cleaning cartridge is not valid, the cleaning solution will not be automatically filled to the cap. Open the front cover and use a dropper to fill the maintenance cleaning solution in the cap to just before it overflows.

Once the cleaning solution is full, begin from Step 7.

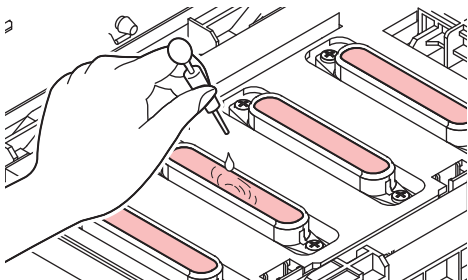

6

If a **END** message is displayed, open the front cover and check the amount of cleaning solution in the cap.

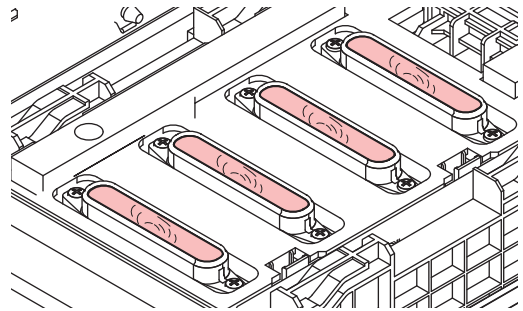

Important!

- If the solution does not fill up the cap, use a dropper to fill the maintenance cleaning solution in the cap to just before it overflows.

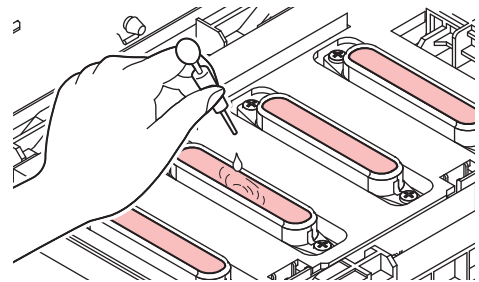

7

Close the front cover, and press the **ENTER** key.

When the Machine Is Not Used for a Long Time

When not using this machine for two days (weekends, etc.)

When you will not be using the machine for a two day period (weekends, etc.), follow the procedure below.

1 Perform each item of daily maintenance.

- Refer to "Maintenance" (☞ P.4-2) for details.

2 Check that the pressure roller is raised and locked.

- The pressure roller utilizes a slide lock. Please check the lock position.
- Media needs to be detached from the main unit.

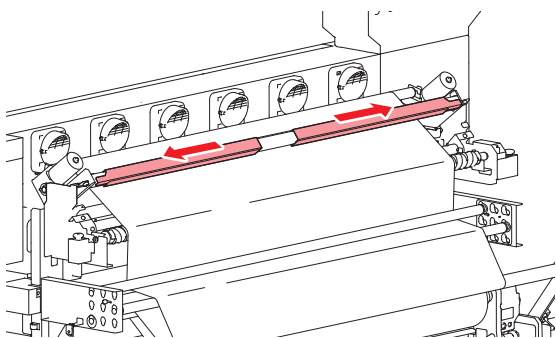

Important!

- Make sure to put up the pressure roller. The pressure roller would stick to the adhesive and not be able to lift up if the pressure roller is in a lowered status for a long period.

3 Open the drainage valve and remove the water from the wash unit.

- Place a bucket under the drainage valve and then open the valve.

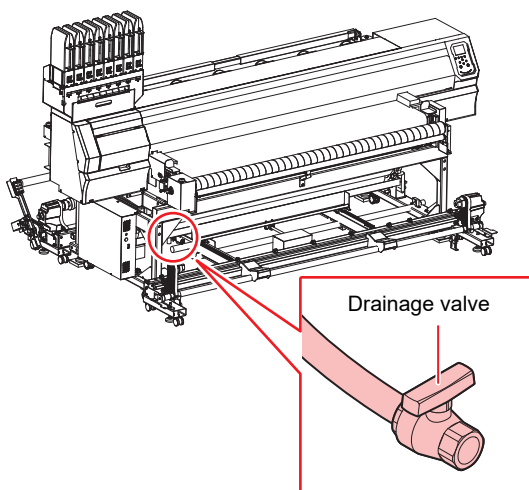

4 Set belt wash to OFF.

- Refer to "Setting Belt Wash" (☞ P.3-11).

5 Remove the absorb roller.

- Remove the pinch screw and rotate the right and left absorb roller fix BKT.

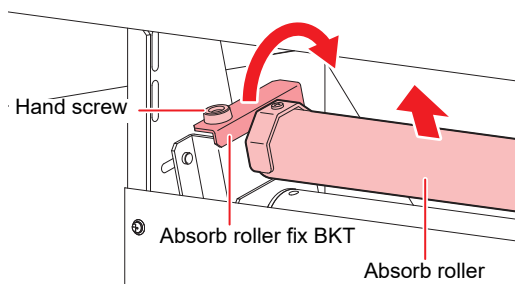

Important!

- Make sure to remove the absorb roller. It may be transformed if keeping the absorb roller pressing for a long time.

When not using this machine for three days (weekends, etc.)

When not using this machine for three days, follow the procedure below.

1 Follow the procedure found in "When not using this machine for two days (weekends, etc.)"

2 Replace waste ink tank with a new one.

- Refer to "If a Waste Ink Tank Confirmation Message Appears" (☞ P.4-21).

When not using this machine for more than 1 week.

When the machine is not going to be used for a week or more, use the cleaning function for custody to clean the head nozzles and ink discharge passage. After this, keep the machine in custody.

Important!

- Use the machine with always turning "ON" the main power. The function preventing nozzle clogging operates automatically to protect the head of the nozzle.
- The head nozzle may result in nozzle clogging if the main power switch is left OFF for a long time.

Check the items on the right beforehand.

Is [NEAR END] or [INK END] displayed?

- The cleaning solution or ink is absorbed when the nozzles are washed. At this time, if the state of "no ink" or "almost no ink" is detected, the nozzle washing operation cannot start.
- Replace the ink IC chip with another from which the state of "almost no ink" or "no ink" is not detected.



- When the warning messages "Check waste ink" are indicated, check the waste ink tank, and operate it, referring to P.4-21 "If a Waste Ink Tank Confirmation Message Appears" according to the situation.

1 Press **FUNC1** (**MENU**) → **ENTER** in **LOCAL**.

- MAINTENANCE MENU will be displayed.

2 Press the **ENTER** key.

- “STATION” will be selected.

3 Press **▲** **▼** to select “CUSTODY WASH”, and press the **ENTER** key.

- Carriage will move onto the belt.

4 When “WIPER CLEANING” appears on the display, open the front cover.

5 Clean the wiper and the bracket.

- (1) Open the front cover then pull out it by holding projections at both ends of the wiper.
- (2) Clean the wiper and bracket with a clean stick dipped in cleaning solution for maintenance. Wipe off so that cleaning solution for maintenance will not remain.
- (3) Insert it in the original position by holding the projections at both ends of the wiper.

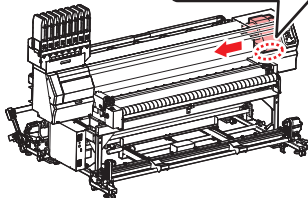
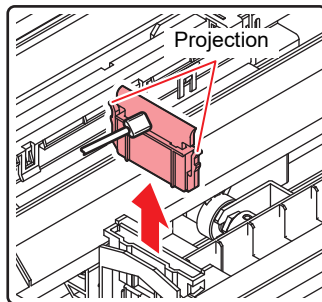

6 Press the **ENTER** key.

- Important!**
- Until wiper cleaning is completed, [COMPLETED (NEXT): ENT] is displayed on the screen. After the work up to the step 5 is completed, press the [ENTER] key. If you press the [ENTER] key before cleaning is completed, the machine moves to the next washing procedure.

7 Clean the cap rubber.

- Wipe off the ink sticking to the cap rubber with a clean stick dipped in maintenance solution for maintenance.
- Wipe off so that maintenance solution for maintenance will not remain.
- At this time, the discharge passage is cleaned automatically.

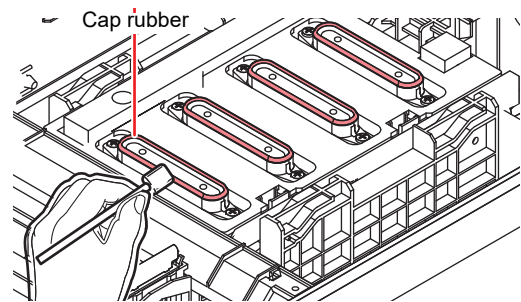

Important!

- After cleaning the cap rubber, check to make sure the cap slider is not tilted. If it is tilted, move the slider block left and right to fix its tilt.

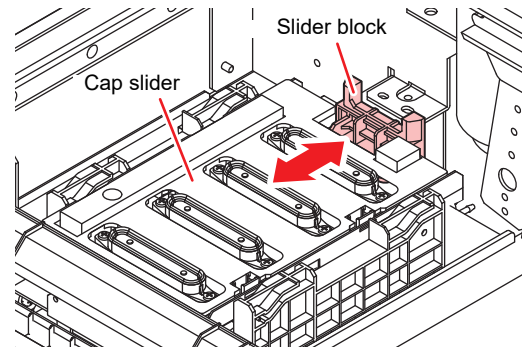

8 Close the front cover and press the **ENTER** key.

9 Fill up the cap with cleaning solution for maintenance.

- If the cleaning solution cartridge is usable, maintenance solution is automatically filled.
- When the cap is filled with cleaning solution, the display will prompt you to check the cleaning solution.

Important!

- If the front cover is not closed, the cleaning solution will not be automatically filled. If the front cover is open, be sure to close it.



- If the cleaning cartridge is not valid, the cleaning solution will not be automatically filled to the cap. Open the front cover and use a dropper to fill the maintenance cleaning solution in the cap to just before it overflows. Once the cleaning solution is full, begin from Step 11.

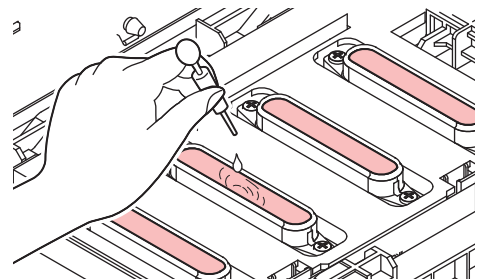

10 If a message is displayed, open the front cover and check the amount of cleaning solution in the cap.

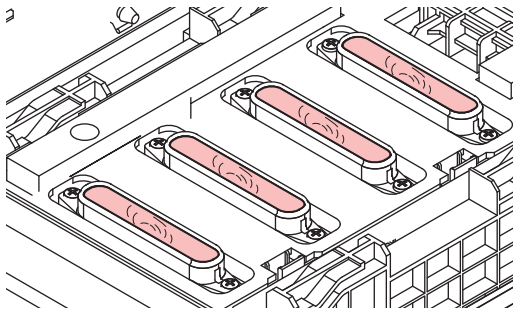

Important! • If the solution does not fill up the cap, use a dropper to fill the maintenance cleaning solution in the cap to just before it overflows.

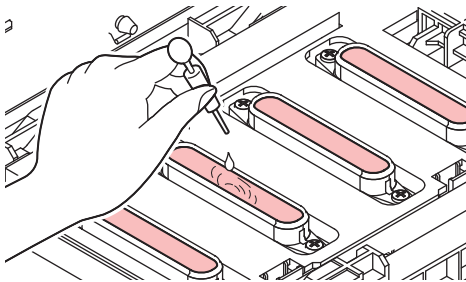

11 Close the front cover, and press the **ENTER** key.

12 Press **▲** **▼** to set the time for the cleaning solution to be left as it is.

• Set Value: 1 to 99 min (by the unit of 1 min)

13 Press the **ENTER** key.

• The nozzles are washed.
• When the nozzles have been completely washed, the head moves to the maintenance position.

14 Fill up the cap with cleaning solution for maintenance.

• If the cleaning solution cartridge is usable, maintenance solution is automatically filled.

Important! • If the front cover is not closed, the cleaning solution will not be automatically filled. If the front cover is open, be sure to close it.



• If the cleaning cartridge is not valid, the cleaning solution will not be automatically filled to the cap. Open the front cover and use a dropper to fill the maintenance cleaning solution in the cap to just before it overflows. Once the cleaning solution is full, begin from Step 16.

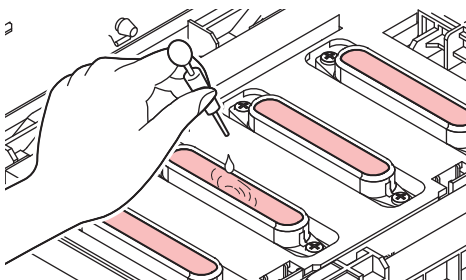

15 If a END message is displayed, open the front cover and check the amount of cleaning solution in the cap.

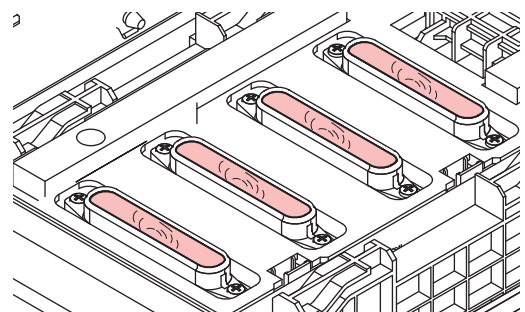

Important! • If the solution does not fill up the cap, use a dropper to fill the maintenance cleaning solution in the cap to just before it overflows.

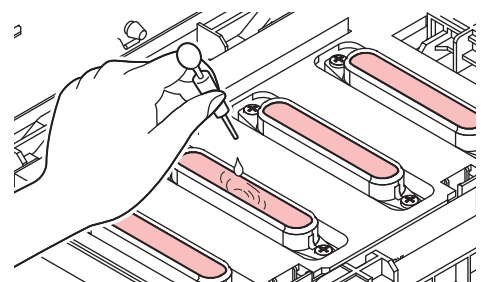

16 Close the front cover and press the **ENTER** key.

• After its initial operation, the machine returns to step2.

When using this machine after not having used it for a long period of time

When you have not used this machine for a long period of time and start using it again, follow the procedure below.

1 Perform head cleaning (hard) and check the ink nozzles.

• Refer to "Head Cleaning" (☞ P.2-27).

2 If there are some clogged nozzles, perform nozzle washing.

• Refer to "Washing the Head Nozzle" (☞ P.4-7).

Cleaning the Ink Head and the Area around It

Because the ink head employs a very precise mechanism, due care needs to be taken when it is cleaned.

Using a clean stick, etc., rub off gelatinous ink or dust that may stick to the lower part of the slider and the area around the ink head. In doing so, never rub the nozzles of the head.

Tools required for cleaning

• Clean stick (SPC-0527)	• Gloves
• Safety glasses	



- Be sure to wear the included safety glasses and gloves when cleaning the area around the ink head. Otherwise, you may get ink in your eyes.
- The ink contains organic solvent. If you get the ink on your skin or in your eyes, wash it away with plenty of water immediately.

1

Press **FUNC1 (MENU)** → **ENTER** in LOCAL.

- MAINTENANCE MENU will be displayed.

2

Press the **ENTER** key twice.

- "CARRIAGE OUT" will be selected.

3

Press **▲** **▼** to select "HEAD MAINTENANCE", and press the **ENTER** key.

- Carriage will move to the left end of this machine.

4

Open the maintenance cover.

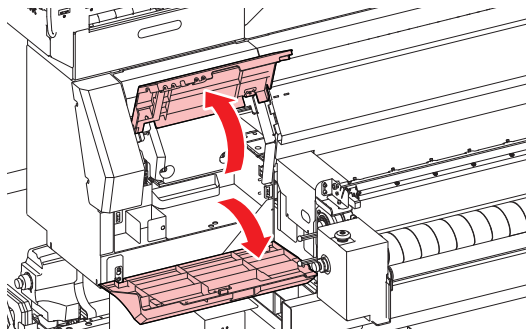

5

Wipe ink sticking to the side of the head off with a clean stick.

- Never rub the nozzles.

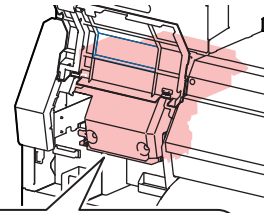

Clean the side surface of the head (shown in deep gray) with a clean stick.

The nozzle part (Never touch it.)

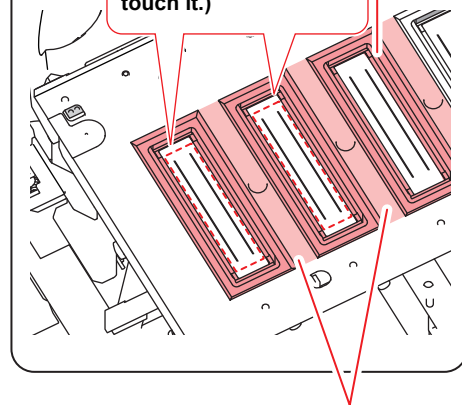

Clean with a clean stick or a waste cloth.

6

Press the **ENTER** key after the cleaning.

7

Close the maintenance cover, and press the **ENTER** key.

- After its initial operation, the machine returns to LOCAL.

Nozzle Recovery Function

NOZZLE RECOVERY: When nozzles missing can not be improved at specific points, other good nozzles can be used as alternatives for printing.

- 1 Press **FUNC1 (MENU)** → **ENTER** in **LOCAL**.
 - MAINTENANCE MENU will be displayed.
- 2 Press **▲▼** to select **“NOZZLE RECOVERY”**, and press the **ENTER** key.
- 3 Press the **ENTER** key twice.
 - Printing of the nozzle pattern will start.
 - Select **“ENTRY”** then **“Move to select of the Nozzle line (Step 4) without drawing a pattern”**

Overhead view

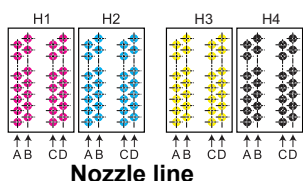

Nozzle pattern of Head 1

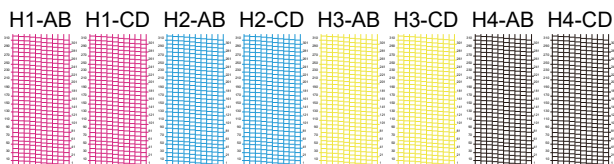

Important! • When using leaf media, set a media of more than A3 size put horizontally. If a media with narrow width is set, printing will only be conducted to midway.

- 4 Select the Nozzle line that needs **NOZZLE RECOVERY** by pressing **▲▼**, and press the **ENTER** key.

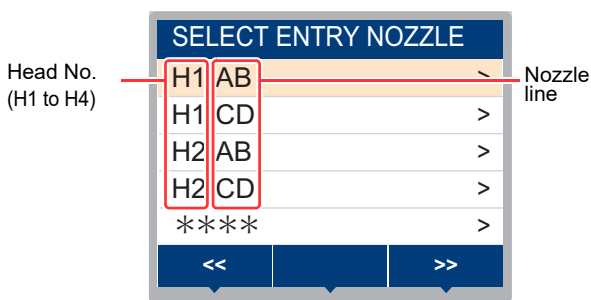

- 5 Register the Nozzle number that needs **NOZZLE RECOVERY** and press the **ENTER** key.

- (1) Select the registration number from 1 to 10 by pressing **▲▼** and press the **[ENTER]** key.
- (2) Register the nozzle number that needs recovery by pressing **▲▼** and press the **[ENTER]** key.

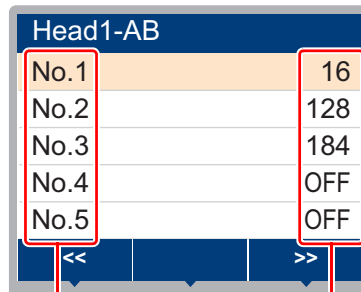

Recovery nozzle No. or OFF

Registration number: 1 to 10

Example of nozzle to be recovered

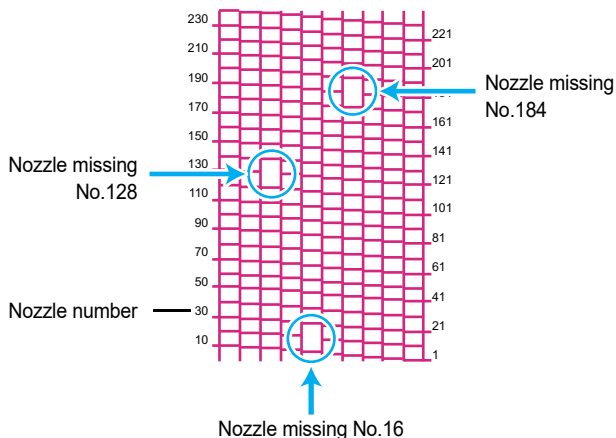

Registration number	Recovery Nozzle No.	State
1	16	Target for nozzle recovery
2	128	Target for nozzle recovery
3	184	Target for nozzle recovery
4	OFF	No registration
5	OFF	No registration

- 6 Press the **END/POWER** key several times to end the setting.

Important! • Up to 10 nozzles can be registered per 1 nozzle line.
 • Even if you use this function, time required for drawing does not change.
 • When printing has been done with the lowest path, nozzle recovery is not reflected.

Reset the set value

- 1 Press **FUNC1** (MENU) → **ENTER** in LOCAL.
• MAINTENANCE MENU will be displayed.
- 2 Press **▲▼** to select “NOZZLE RECOVERY”, and press the **ENTER** key.
- 3 Press **▲▼** to select “RESET”, and press the **ENTER** key.
- 4 Press **▲▼** and **FUNC1** (PAGE>) **FUNC3** (<<) to select the Nozzle line that need reset, and press the **ENTER** key.
• A reset confirmation message will be displayed.
- 5 Press the **ENTER** key.
- 6 Press the **END/POWER** key several times to end the setting.

Check the condition for which nozzle recovery cannot be performed

- 1 Press **FUNC1** (MENU) → **ENTER** in LOCAL.
• MAINTENANCE MENU will be displayed.
- 2 Press **▲▼** to select “NOZZLE RECOVERY”, and press the **ENTER** key.
- 3 Press **▲▼** to select “CHECK”, and press the **ENTER** key.
• Judgement Condition input screen will be displayed.

Judgement Condition	
Resolution	720 x 720
PASS	8
Scan Speed	NORMAL
MAPS 4	>
OVER PRINT	1



- When using two types of ink with the hybrid function, please select the type of ink to check.

Judgement Condition	
Select ink type	
: Sb420	

4 Adapt each item of the judgment conditions to your current state.

- (1) Press **▲▼** to select the setting item, and press the **ENTER** key.
- (2) Press **▲▼** to select the setting value, and press the **ENTER** key.
- (3) Repeat steps (1) and (2), and set all of the items.

5 Press **FUNC2**.

- Begin to check if nozzle recovery at the set printing conditions can be done.
- When the check is completed, the judgment result is displayed on the screen.

If the nozzle recovery possible

Judgement result	
Judgement result	OK

If the nozzle recovery is not possible

Judgement result	
Judgement result	NG
HEAD1-AB	1
HEAD1-CD	0
HEAD2-AB	0
HEAD2-CD	2
Judgement result	
HEAD3-AB	1
HEAD3-CD	0
HEAD4-AB	0
HEAD4-CD	0

Head no. and nozzle line The number of nozzles that can not be recovered.

6 Press **END/POWER** several times to end the setting.

Enabling or disabling nozzle recovery during a test print

To enable the nozzle recovery function during a test print (P.2-24), turn the following settings “ON”, and register the numbers of the nozzles for recovery in “Nozzle Recovery Function” on P.4-14.

- 1 Press **FUNC1 (MENU)** → **ENTER** in LOCAL.
• MAINTENANCE MENU will be displayed.
- 2 Press **▲▼** to select “NOZZLE RECOVERY”, and press the **ENTER** key.
- 3 Press **▲▼** to select “TEST PRINT”, and press the **ENTER** key.
- 4 Press **▲▼** to select ON/OFF, and press the **ENTER** key.
- 5 Press the **END/POWER** key several times to end.

Automatic Maintenance Function

To use this machine comfortably, you can set various maintenances to be performed automatically. Here, set performing intervals of various automatic maintenances.

You can prevent troubles such as ink clogging by performing automatic maintenance periodically (automatic maintenance function).

For the auto maintenance functions, the following items can be set:

- Important!**
- When you perform maintenance manually, after manual maintenance is completed and when time set with the automatic maintenance function has passed, maintenance starts automatically.
 - If using the Automatic Maintenance Function, make sure that the maintenance washing liquid is set. If the maintenance washing liquid is not set, tube washing operation will not be regularly conducted and the passage could be clogged.

Function name	Descriptions
REFRESH	The interval between each refreshing operation is set.
PUMP TUBE CLEANING	The activation interval for tube washing is set.
CLEANING (Interval)	The interval between each cleaning operation is set.
CLEANING (Type)	The cleaning type is set.
NOZZLE WASH	Setting for the action can not be changed.

- Important!**
- If the “Check waste ink” warning message is displayed, the operation set in the auto maintenance function is not carried out. Perform the operations of P.4-21 “Replace the waste ink tank with another” if required.
 - When the power switch on the front of the machine is turned off, check the waste ink tank.

Setting the Refreshing Intervals

The interval between each operation of ejecting a small amount of ink from the nozzles to prevent nozzle clogging is set.

- 1 Press **FUNC1 (MENU)** → **ENTER** in LOCAL.
• MAINTENANCE MENU will be displayed.
- 2 Press **▲▼** to select “AUTO MAINTENANCE”, and press the **ENTER** key.
- 3 Press the **ENTER** key.
• “REFRESH” will be selected.
- 4 Press **▲▼** to set the refreshing interval, and press the **ENTER** key.
• **Set value** : The set value will differ according to the ink type being used.
- 5 Press the **END/POWER** key several times to end the setting.

Setting the Tube Wash Intervals

For setting the interval at which washing of the ink tubes will be carried out, in order to prevent ink clogging due to coagulation of ink inside the ink tubes.



- In order to perform tube washing with the Automatic Maintenance Function, the maintenance washing liquid needs to be set. If the maintenance washing liquid is not set, tube washing operation will not be regularly conducted and the passage could be clogged.

- 1 Press **FUNC1** (MENU) → **▼** → **ENTER** in LOCAL.
 - MAINTENANCE MENU will be displayed.
- 2 Press **▲** **▼** to select "AUTO MAINTENANCE", and press the **ENTER** key.
- 3 Press **▼**, and press **ENTER**.
 - "PUMP TUBE CLEANING" will be selected.
- 4 Press **▲** **▼** to set the tube washing interval, and press **ENTER**.
 - **Set value** : The set value will differ according to the ink type being used.
- 5 Press the **END/POWER** key several times to end the setting.

Setting the Cleaning Intervals and Type

The cleaning type and the interval between each cleaning operation are set.

- 1 Press **FUNC1** (MENU) → **▼** → **ENTER** in LOCAL.
 - MAINTENANCE MENU will be displayed.
- 2 Press **▲** **▼** to select "AUTO MAINTENANCE", and press the **ENTER** key.
- 3 Press **▼** several times to select "Interval" or "Type", and press the **ENTER** key.
- 4 Press **▲** **▼** to select a set value, and press the **ENTER** key.
 - **Set value** : The set value will differ according to the ink type being used.
 - **Set value of type** : NORMAL/ HARD



- "Soft" can also be set when reactive dye ink Rc 400 or Rc 500 is used.

- 5 Press the **END/POWER** key several times to end the setting.

Suspend the nozzle cleaning

When you want to work as such a printing during the nozzle cleaning, you can interrupt the nozzle cleaning.



- If the nozzle cleaning is interrupted, run the head cleaning without waiting for the configured cleaning time.

- 1 Press the **END/POWER** key during the nozzle cleaning implement.

- Display the selection screen of the nozzle cleaning stop.

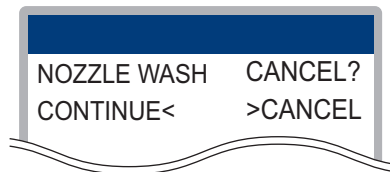

- 2 Press **▶** to select "CANCEL".



- If you want to continue the nozzle cleaning, please select [**◀**](CONTINUE).
- When reactive dye ink Rc 400 or Rc 500 is used and the nozzle cleaning is stopped, the soft cleaning will be started.

Fill up Ink

Supplies ink to correct nozzle clogging.

- 1 Press **FUNC1 (MENU)** → **▼** → **ENTER** in LOCAL.
 - MAINTENANCE MENU will be displayed.
- 2 Press **▲** **▼** to select “FILL UP INK”, and press the **ENTER** key.
- 3 Press **▲** **▼** to select the filling head, and press the **ENTER** key.
- 4 Press the **ENTER** key.
 - Ink is supplied automatically.
- 5 Press the **END/POWER** key several times to end the setting.

Replacing consumables

Use the supply items to replace parts if they are excessively dirty, damaged, or deformed.

To order replacement consumable items, contact your local dealer or our service office.

For more information on other consumable items, refer to our website. <https://mimaki.com/supply/inkjet.html>

Replacing the wiper

The wiper is consumable. When the display indicates the warning message “Replace a WIPER” it is necessary to check and replace the wiper, immediately replace the wiper with a new one.

Also, wipe ink sticking to the lower surface of the slider off.

Important!

- When the warning message for replacing wiper is shown, confirm whether there is no damage and fuzz at the top edge of the wiper film. If there is no damage on the top edge of the wiper film, it is possible to use the wiper continuously without replacing it.
- A cleaning wiper is an option. Buy one through the dealer in your region or at our service office.

- 1 Press **FUNC1 (MENU)** → **▼** → **ENTER** in LOCAL.
 - MAINTENANCE MENU will be displayed.
- 2 Press the **ENTER** key.
 - “STATION” will be selected.
- 3 Press **▲** **▼** to select “WIPER EXCHANGE”, and press the **ENTER** key.
- 4 Press the **ENTER** key.
 - The carriage will move onto the belt.

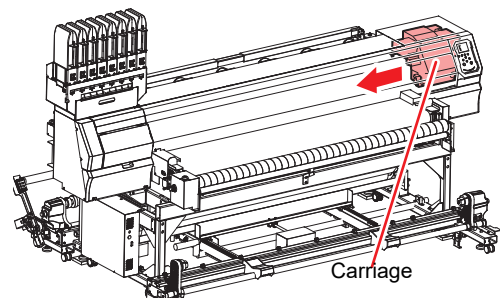

- 5 **Remove the wiper.**
 - Pull out the wiper by holding the protrusions at its both ends.

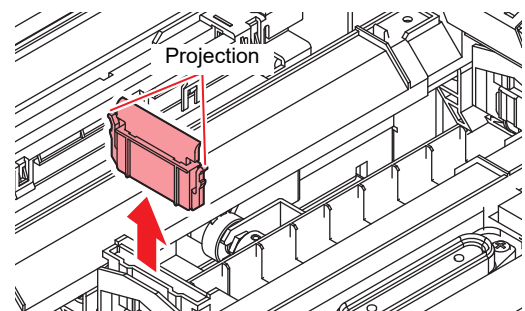

6 Insert a new wiper.

- Insert the wiper by holding the protrusions at its both ends.

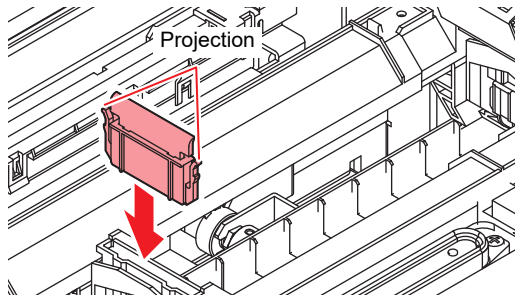

7 Close the front cover, and press the **ENTER** key.

- After its initial operation, the machine returns to LOCAL.

Replacing the Spout Rubber

Install the spout rubber in an eco case in order to reduce ink leakage from the 2L ink pack.

The spout rubber is a supplied part. (SPA-0317: Set of 8 Rubber stopper 2L for case)

The replacing timing sign of the spout rubber will be shown about once every half-year. Please replace the spout rubber when you see the sign on the display.



- When exchanging 2L ink pack, be sure to wear the included safety glasses and gloves. Ink may spatter and get in your eyes accidentally.



- Replace all eight spout rubber as a set at the same time.
- Depending on the usage environment and usage conditions, the spout rubber may deteriorate within half a year. If the gap in the center expands as shown in the picture, please replace it regardless of if there is a warning message.



The beginning of spout rubber



It is available to use



It is necessary to replace



• Reset the counter according to the following procedures if replacing any time other than when the warning is displayed

- (1) Press the **(FUNC1)** key in LOCAL to select "INFORMATION" and press the **(ENTER)** key.
- (2) Select "USAGE" and press the **(ENTER)** key.
- (3) Press the **(FUNC3)** key
- (4) If the following appears, press the **(ENTER)** key to reset the counter.

EcoCase/SpoutRubber
RESET? [ENT]

1 Open the 2L eco case.

2 Remove the 2L ink pack.

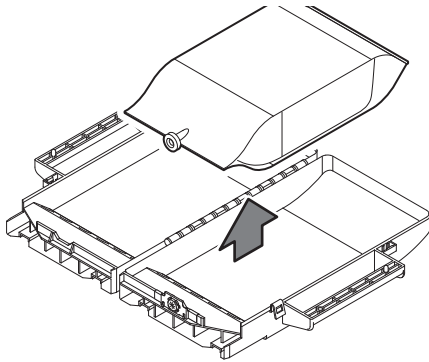

3 Remove the spout rubber.

• Press against the top of the spout rubber and pull it out vertically.

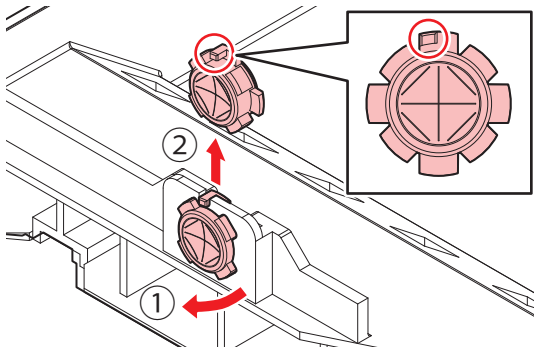

4 Attach the new spout rubber from outside of the eco-case.

- Insert it aligning the positioning protrusion of the spout rubber to the concave position of the eco-case.
- Be careful of the direction of the rubber when installing.
- Push the entire rubber into groove until the spout rubber fits evenly.



• Bending the entire spout rubber makes it easier to insert from the outside of the case.

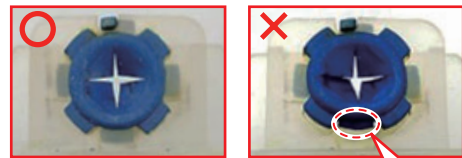
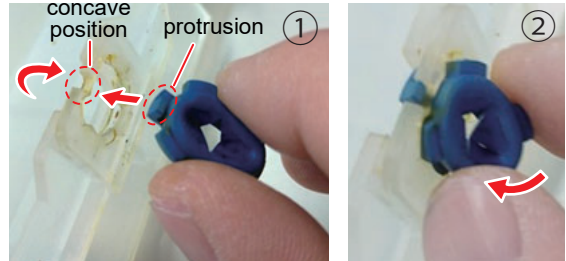

The rib don't fit.If it is not seated in the groove correctly, the spout rubber will be damaged.

5 Moisten the surface of the spout rubber with maintenance solution sufficiently before inserting.

- Inserting the rubber into the eco-case without moistening may damage the rubber.
- In that case, use a maintenance solution that is suitable for the ink type.

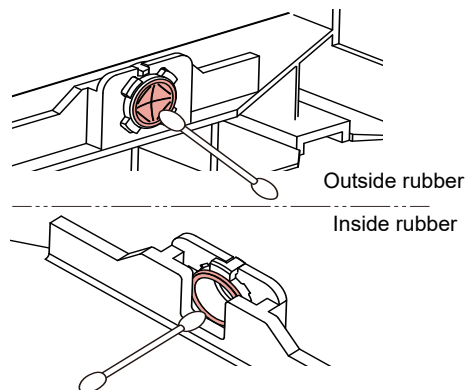

If a Waste Ink Tank Confirmation Message Appears

Ink used in head cleaning, etc. is stored in the waste ink tank on the lower right side of the machine. This machine counts the accumulated amount of discharged ink. When that reaches a specified amount, the machine displays a confirmation message. (When this message is displayed, consider the replacement of the waste ink tank.)



- The message is displayed when it reaches 80% (1.6L) of the 2L tank on the lower right side of the machine.



- The waste ink tank on the left does not cumulatively count the amount of discharge of such a substance as ink. Even if the level of dirty water in the tank becomes 80% or over, no message appears. Check the level of dirty water in the tank on the left often and dispose of dirty water if pooled.

Confirmation Message in LOCAL

1 The warning message “Check waste ink” is displayed.

2 Check the state of the waste ink tank

- For any difference between the displayed level and the actual level of discharge amount, carry out the operations described in and after step 3.
- If there is no difference between the displayed level and the actual level, and if you replace (dispose of) the waste ink tank, carry out the procedure described in “Replace the waste ink tank with another” (P.4-21)

3 Press **FUNC1** (MENU) → **ENTER** in LOCAL.

- MAINTENANCE MENU will be displayed.

4 Press **ENTER** to select “INK TANK EXCHANGE”, and press the **ENTER** key.

5 If the amount of waste ink needs to be adjusted, press the **ENTER** key.

6 Press **ENTER** to adjust the level, and press the **ENTER** key.

7 Press the **ENTER** key.

Replace the waste ink tank with another

When the waste ink tank becomes full, carry out the procedure below to replace the waste ink tank, and in the Maintenance menu, set 0% for waste ink tank information. If you replace the waste ink tank before the waste ink tank confirmation message is displayed (before the 2L tank is 80% (1.6L) full), carry out the same procedure to replace the waste ink tank.

1 Press **FUNC1** (MENU) → **ENTER** in LOCAL.

- MAINTENANCE MENU will be displayed.

2 Press **ENTER** to select “REPLACE WasteInkTank”, and press the **ENTER** key.

- Waste ink tank information is displayed.

3 Press **ENTER** to adjust the level, and press the **ENTER** key.

4 Press the **ENTER** key.

- The waste ink tank amount that is managed in this machine will be reset.

5 Pull the waste ink tank stopper to open to the front.

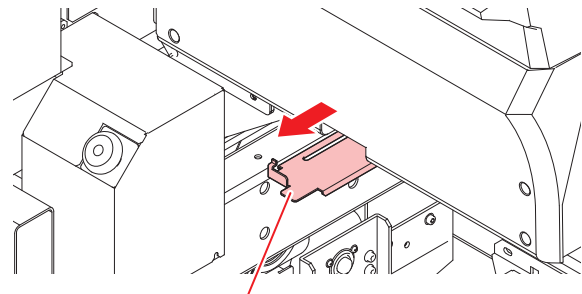

Waste ink tank stopper

6 Pull it frontward to remove by holding the waste ink tank handle.

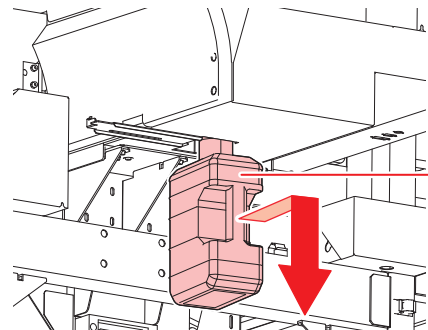

Waste ink tank



- Put a cap on the waste ink tank removed.

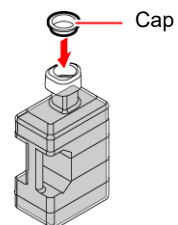

Cap

7 Replace the waste ink tank.

- Prepare a new waste ink tank (SPC-0117) or discard waste ink from current waste ink tank.
- Insert the waste ink tank by holding a handle of the tank.

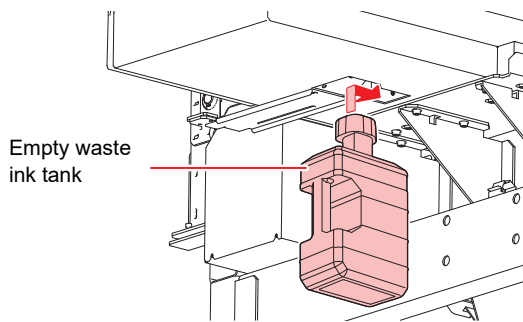

• Waste ink is equivalent to waste oil of industrial waste. Request an industrial waste disposal company for disposal of waste ink.

8 Close the waste ink tank stopper.

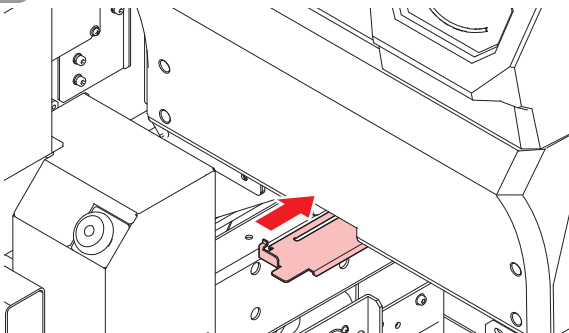

9 Press the **ENTER** key.

• The ink discharging amount that is controlled by the machine is reset and the message is cancelled.

Replacing the Water

Replace the water if a belt wash was performed but the feeding belt is still soiled. Replace the washing water every day when not using in flow.

1 Press **FUNC1** (MENU) → **ENTER** in LOCAL.

• MAINTENANCE MENU will be displayed.

2 Press **UP** **DOWN** to select "REPLACE WATER", and press the **ENTER** key.

• The replace water setting screen is displayed.

3 Press **UP** **DOWN** to select "DRAIN", and press the **ENTER** key.

4 Press the **ENTER** key.

• The message "The wash unit is moving. Please wait momentarily." is displayed.

5 Once the message "Water will be drained. Please open the drainage valve." is displayed, place a bucket under the drainage valve and then open the valve.

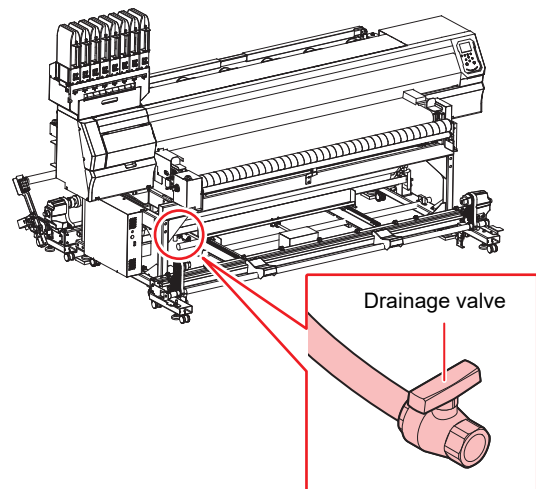

6 Press the **ENTER** key.

• Water drainage will begin and the message "Water is being drained. Please wait momentarily." will be displayed.

7 Once the message "Draining completed. Please close the drainage valve." is displayed, close the drainage valve.

8 Press the **ENTER** key.

• The message "Do you want to supply water?" is displayed.

9 Press the **ENTER** key.

• The message "Water will be supplied. Please close the drainage valve." is displayed.

10 Close the drainage valve, and press the **ENTER** key.

11 Once the message "Water will be supplied." is displayed, press the **ENTER** key.

- Water supply will begin and the message "Water is being supplied. Please wait momentarily." will be displayed.



- When the quantity of water supply is too much or few, adjust it by the cook of the water supply valve.

12 Once the message "Water supply completed." is displayed, press the **ENTER** key.

13 Press the **ENTER** key.

- The message "The wash unit is returning to standby position. Please wait momentarily" is displayed.
- Once the wash unit has returned to standby position, the replace water setting screen will be displayed.

Wash Unit Maintenance

Cleaning the Belt Wash Unit

Move the belt washing unit to the maintenance position and perform the cleaning of the washing brush and inside of the tray.

1 Press **FUNC1 (MENU)** → **ENTER** in LOCAL.

- MAINTENANCE MENU will be displayed.

2 Press **▲ ▼** to select "BELT WASH UNIT", and press the **ENTER** key

- The washing unit maintenance start page will be displayed.

3 Press the **ENTER** key.

- When setting the media using the feeding tension bar, the tension bar falls down.

4 Remove the feeding unit.

- When the media has been placed, remove it.
- Remove the feeding unit out from the machine and move it.

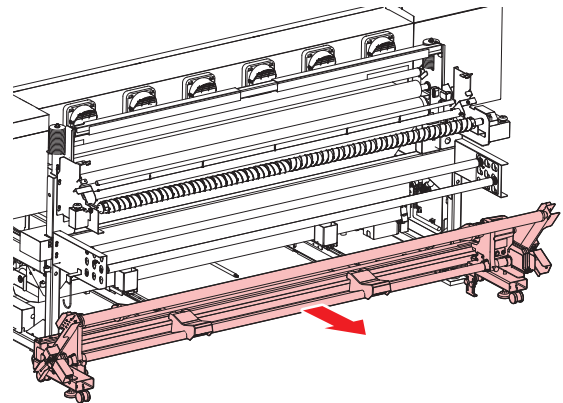

5 Press the **ENTER** key.

- Wash unit movement instructions will be displayed.

6 Press the **ENTER** key.

- The wash unit will move towards the back of the machine.

7 Clean the washing unit.



- When you want to divert water to the washing tray, press the [ENTER] key. The water supply valve opens to supply water to the washing tray.
- When you want to turn off water, press the [ENTER] key once again. The water supply valve is closed.

Important!

- Before supplying water from the water supply valve, confirm that the discharge hose is not clogged up.
- If supplying water with the discharge hose clogged, it becomes a cause that water overflows from the washing tray.

8 Once cleaning has been completed, press the **END/POWER** key.

- The cleaning completed confirmation screen will be displayed.

9 Press the **ENTER** key.

- The wash unit movement confirmation screen will be displayed.

10 Press the **ENTER** key.

- The wash unit will move back to its original position.

11 Install the feeding unit.

- Reinstall the feeding unit which was removed.

Important!

- Please be sure to install the feeding unit when this screen is displayed.

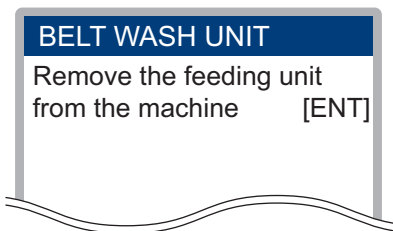

12 Press the **ENTER** key.

- The maintenance completed screen will be displayed.

13 Press the **ENTER** key.

Absorb Roller Cleaning

A dirt accumulates on the water absorption roller when using a belt washing function. Clean the water absorption roller to keep the drawing quality high.



- Setting the absorb roller cleaning notification time allows you to carry out work without being concerned with when the absorb roller needs to be cleaned since the machine will notify you when it needs to be cleaned.
- Refer to P.3-12 "Setting Maintenance Notification Time (COUNTER LIMIT)"



- Spread out waste paper, etc. on the floor before cleaning so that the water does not soil the floor.
- Please wear rubber gloves before cleaning.

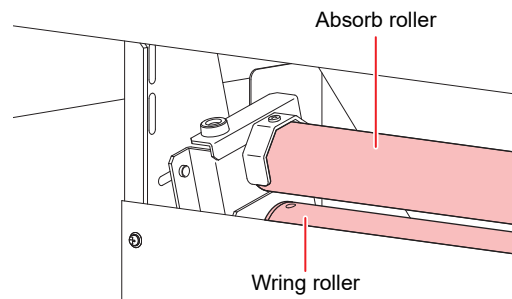

1 Press **FUNC1 (MENU)** → **ENTER** in LOCAL.

- MAINTENANCE MENU will be displayed.

2 Press **UP** **DOWN** to select "Belt washing unit", and press the **ENTER** key

- The belt washing unit start screen will be displayed.

3 Press the **ENTER** key.

- The feeding tension bar will lower if it is being used and the media is set.

4 Remove the feeding unit.

- If media is set, please remove the media.
- Remove the feeding unit from the machine and move it out of the way.

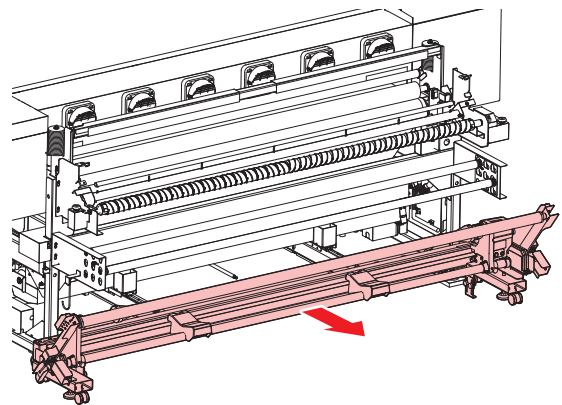

5 Press the **ENTER** key.

- Wash unit movement instructions will be displayed.

6 Press the **ENTER** key.
 • The wash unit will move towards the back of the machine.

7 Remove the hand screw and rotate the right and left absorb roller fix BKT.
 • The absorb roller is located inside the machine towards the back.

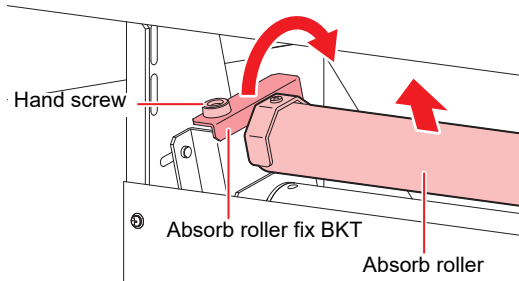

8 Remove the absorb roller from the machine.



• At least two people should be involved in removing the absorb roller.

9 Remove any water from the absorb roller.
 (1) Remove the screws from both ends with a screw driver and perform cleaning with removing frames one by one.

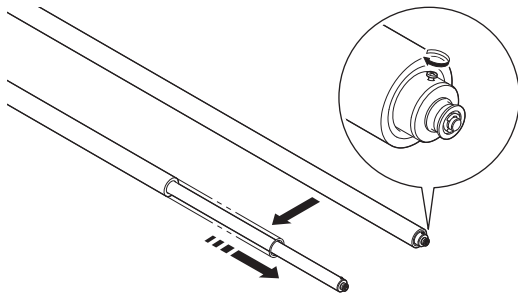

(2) Use tap water, etc. to wash away any impurities from the roller.

Important! • Do not twist the sponge.

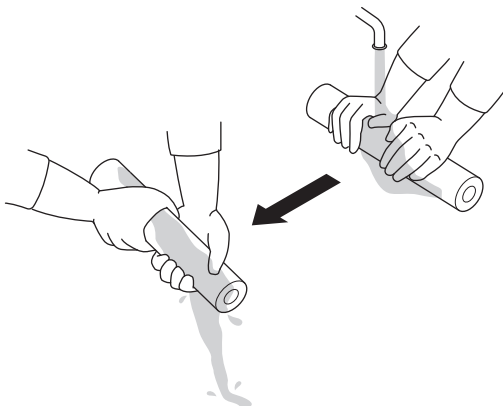

(3) Once impurities have been washed away, use a waste cloth (Bemcot, etc.) or similar cleaning aid to wrap around the sponge section and remove any water.

Important! • Do not twist the sponge.

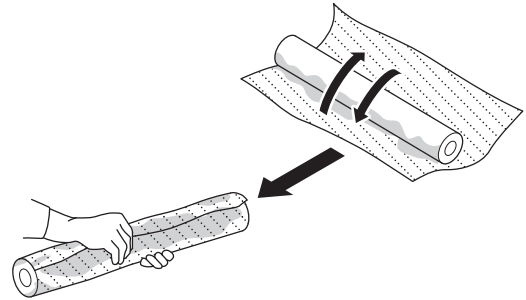

(4) Once it has been dried well enough, reinstall section.

10 Reinstall the absorb roller
 • Reset the counter is a warning message is displayed.
 "Resetting the Counter" (☞ P.4-33)

Important! • Move the absorb roller to the center to avoid a gap and then fix.

11 Once cleaning has been completed, press the **END** key.
 • The cleaning completed confirmation screen will be displayed.

12 Press the **ENTER** key.
 • The wash unit movement confirmation screen will be displayed.

13 Press the **ENTER** key.
 • The wash unit will move back to its original position.

14 Install the feeding unit.
 • Reinstall the feeding unit which was removed.
Important! • Please be sure to install the feeding unit when this screen is displayed.

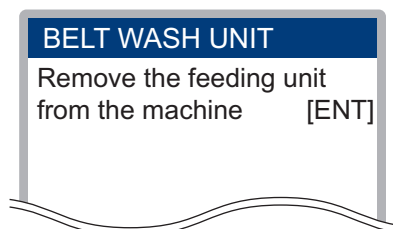

15 Press the **ENTER** key.
 • The maintenance completed screen will be displayed.

16 Press the **ENTER** key.

Reapplying Adhesive

It is necessary to reapplying adhesive when fabric adhesion becomes weak.

Although a coat of adhesive is applied to the belt of this machine before being shipped from the factory, it is necessary to reapply adhesive if adhesive strength diminishes due to adhesion of ink, lint, dust, etc.



- When adhesive should be reapplied
Adhesive should be replaced if the fabric is slacking when it comes out from the front cover. Once the warning message "Belt Adhesive Reapply Adhesive" is displayed, please quickly apply adhesive.



- Genuine Mimaki adhesive is a solvent-type adhesive. Therefore, be sure to wear a protective mask designed for use around organic solvents, safety glasses, and gloves before reapplying adhesive.
- Be sure set up ventilation equipment when applying adhesive in rooms with poor ventilation or in airtight rooms.
- When using adhesive, please follow the Ordinance on the Prevention of Organic Solvent Poisoning. In addition, when reapplying adhesive, such work should be conducted by someone who completed the skill training course for operation chief of organic solvent or by persons selected by them.
- Adhesive is not the cause of fabric slacking before the machine is used or for loosening to occur when fabric is stuck to the feeding belt (when passing through the pressure roller section). That fabric cannot be used.

Peeling Off Adhesive

The following items are required for peeling off adhesive.

- Items to be used
Doctor, gloves
- Items to be prepared
Waste cloth
Kerosene or diesel oil (approx. 500cc)
Ethanol (approx. 200cc)
Tray-shaped metal plate or an oil proof resin plate.



- It would be helpful to pour kerosene (diesel oil) and ethanol in small containers.

1 Remove the cover of belt correction unit.

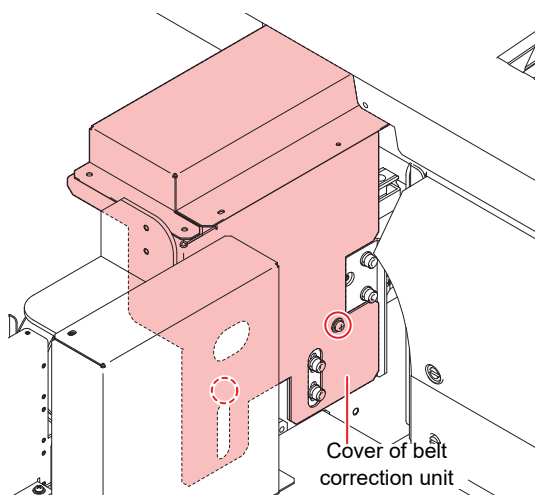

2 Press **FUNC1** (MENU) → **ENTER** in LOCAL.

- MAINTENANCE MENU will be displayed.

3 Press **UP** **DOWN** to select "BELT ADHESIVE", and press the **ENTER** key

- The belt adhesive confirmation screen will be displayed.

4 Press **UP** **DOWN** to select "Peel off adhesive", and press the **ENTER** key.

5 Once the message "Remove Media" has been displayed, confirm that there is no fabric on the feeding belt and press the **ENTER** key.

6 Once the message "Raise the Pressure Roller" has been displayed, raise the back pressure roller and then press the **ENTER** key.

7 Once the message "Set the doctor" has been displayed, set the doctor in the front section of the machine.

- Set the doctor with a gap between the doctor and the belt.

- (1) Loosen the doctor adjust plates (right and left both sides) and move it to the upper end, and then fix provisionally.

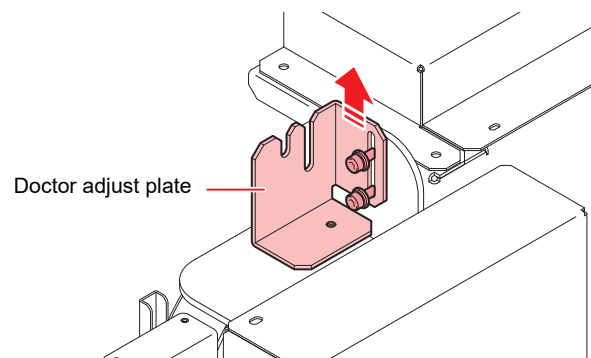

- (2) Loosen the guide blocks (right and left both sides) of the doctor so that it can move up and down by its own weight.

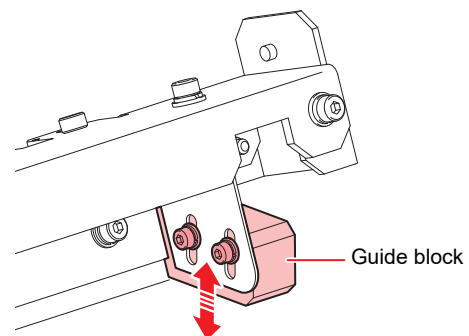

(3) Attach the doctor and fix with a screw.

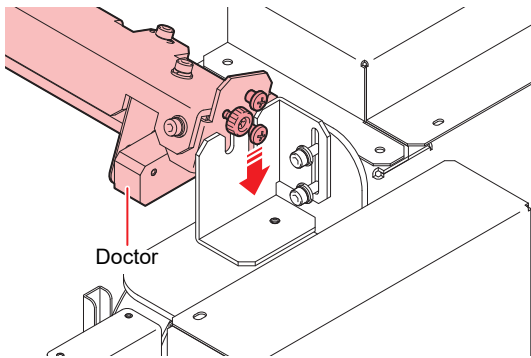

(4) Adjust the height of the doctor adjust plate at around the position where the doctor blade hits against the feeding belt.

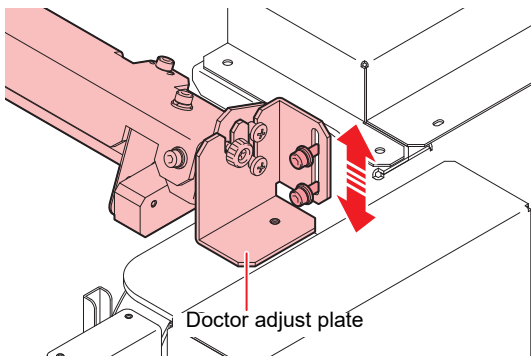

8 Press to set the feed speed, and press the **ENTER** key.

- Set Value: 5 to 60 mm/s
- The feed speed 20 mm/s is recommended.



9 Place fabric which has been soaked well in kerosene along the inner side of the doctor above the feeding belt.

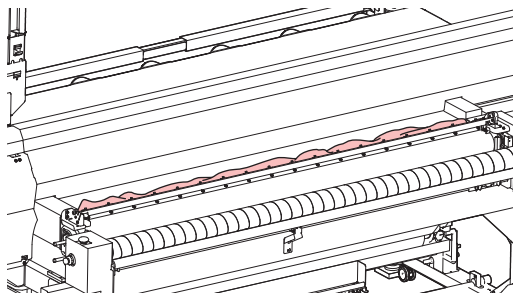

10 Press the **ENTER** key.

- The feeding belt will move.
- Press the **FUNC2** (PAUSE) key to temporarily stop feeding belt operation.
- Press **FUNC1** (SPEED UP) **FUNC3** (SPEED DOWN) to change the feed speed if desired.



11 Pour kerosene or diesel oil on the back side of the fabric.

- Please allow the kerosene or diesel oil to sufficiently absorb into the adhesive on the surface of the belt.

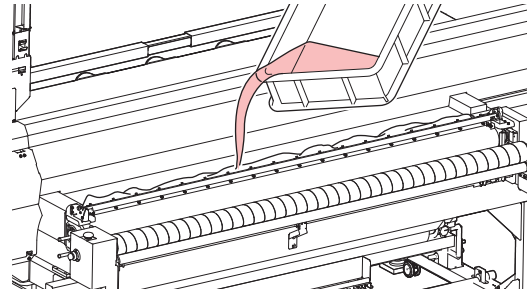

Important!

- If too much kerosene (diesel oil) is poured during adhesive peeling, it may leak from the ends of the doctor travelling to the feeding belt and enter the water receiver.
- If kerosene (diesel oil) mixes with the water, it will cause the adhesive to lose strength when printing from belt wash.
- It is possible that kerosene (diesel oil) has mixed with the water is adhesive has lost strength quickly after it was reapplied.
- After peeling off and reapplying adhesive, please be sure to check the water tray to see whether or not kerosene (diesel oil) has mixed with the water.
- If you have found that kerosene (diesel oil) has mixed with the water, clean the washing tray and the washing brush wash the feeding belt by selecting "REPLACE WATER→CLEANING WASH TRAY" from the maintenance menu. (P.4-32) Add a small amount of neutral detergent to the water tank and operate the feeding belt. Afterwards, replace the water in the tank with new water.

12 Remove the adhesive which has turned into a gel-like state due to the kerosene (diesel oil) by pressing the edge of the plate on the outside of the feeding belt.

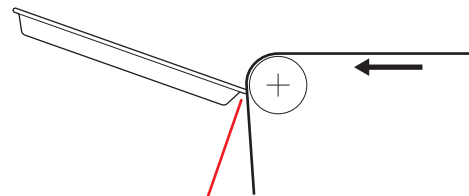

Do not use a tapered edge
(This is done to avoid damaging the belt.)

13 Use a waste cloth to wipe off as much kerosene (diesel oil) as possible from the belt surface.

14 Using a waste cloth soaked in ethanol, wipe away any oil remaining to clean the belt surface.

15 Press **[END]** **ENTER** keys to stop feeding belt operation.

16 Once the message "Adhesive Counter Reset?" has been displayed, press the **ENTER** key.

- This will reset the adhesive counter.

17

Remove the doctor and clean any adhesive, dirty, or other contaminants using kerosene (diesel oil) and a waste cloth.

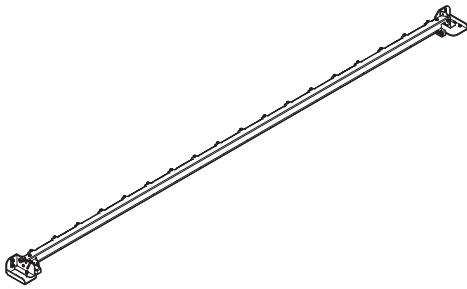

Applying Adhesive

The following items are required for applying adhesive.

- Items to be used
 - Doctor, gloves
 - Vinyl tape of 2 mm width
 - Adhesive (Polixresin SX 1L) (sold separately)
- Genuine Mimaki adhesive is a solvent-type adhesive. Therefore, be sure to wear a protective mask designed for use around organic solvents, safety glasses, and gloves before reapplying adhesive.
- Be sure set up ventilation equipment when applying adhesive in rooms with poor ventilation or in airtight rooms.
- When using adhesive, please follow the Ordinance on the Prevention of Organic Solvent Poisoning. In addition, when reapplying adhesive, such work should be conducted by someone who completed the skill training course for operation chief of organic solvent or by persons selected by them.
- As a fire is strictly prohibited at the time of repainting adhesive, make sure to turn off the power of circumjacent devices (such as a heater). In addition, please perform ventilation by all means.



(Important!)

- When using commercial adhesive, be sure to check the compatibility of the solvent component with the material of the belt of this machine. In this case, contact your dealer or nearest Mimaki sales office.
- Be careful not to allow adhesive to adhere to the contact area of the belt correction unit on the right side of the front panel and around the $\phi 6$ hole. Adhesive may disturb normal operation of the device.



- Avoid the stack coating of the adhesive as much as possible because it may cause a feed error.
- A rough indication of the exchange period of the adhesive is two weeks. (it varies according to the use situation and a type of the media.)

1 Press **FUNC1** (MENU) \rightarrow \downarrow \rightarrow **ENTER** in LOCAL.

- MAINTENANCE MENU will be displayed.

2 Press \uparrow \downarrow to select "BELT ADHESIVE", and press the **ENTER** key

- The belt adhesive confirmation screen will be displayed.

3 Press \uparrow \downarrow to select "Applying Adhesive", and press the **ENTER** key.

4 Once the message "Remove Media" has been displayed, confirm that there is no fabric on the feeding belt and press the **ENTER** key.

5 Once the message "Raise the Pressure Roller" has been displayed, raise the back

pressure roller and then press the **ENTER** key.

6 Place vinyl tape on the sides of the feeding belt.



- It is necessary to place vinyl tape on the left and right sides of the feeding belt.
- If needed, have at least two people perform the work, completing taping for both sides.

7 Press the **ENTER** key two times.

- The feeding belt moves and stops after 1 round. Press the **FUNC2** (PAUSE) key to pause the feeding belt.
- Press [SPEED UP][SPEED DOWN] to change the feed speed if desired.

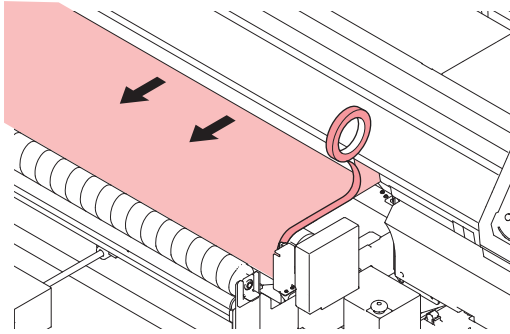

8 Press the **ENTER** key.

- When failed in pasting a tape, choose [END]. Carry out the step 7 once again afterwards.

9 Once the message “Set the doctor” has been displayed, set the doctor in the front section of the machine.

- Set the doctor with a gap between the doctor and the belt.

(1) Loosen the doctor adjust plates (right and left both sides) and move it to the upper end, and then fix provisionally.

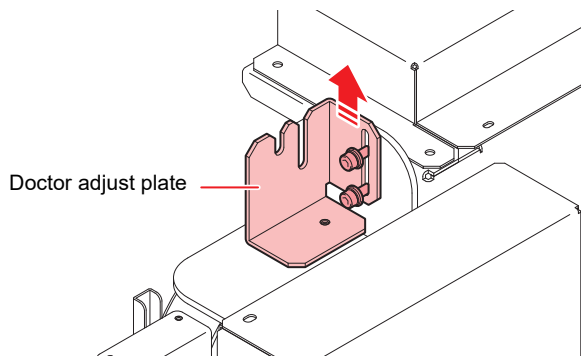

(2) Loosen the guide blocks (right and left both sides) of the doctor so that it can move up and down by its own weight.

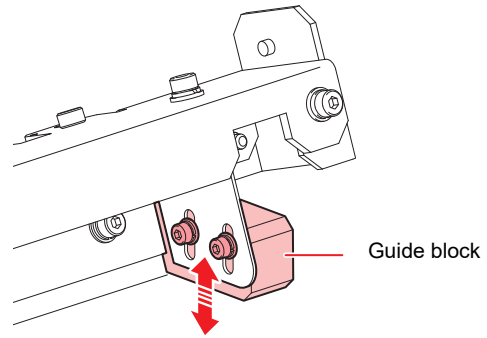

(3) Attach the doctor and fix with a screw.

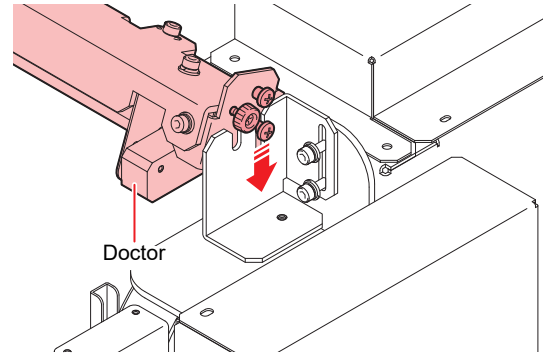

(4) Adjust the height of the doctor adjust plate at around the position where the doctor blade hits against the feeding belt.

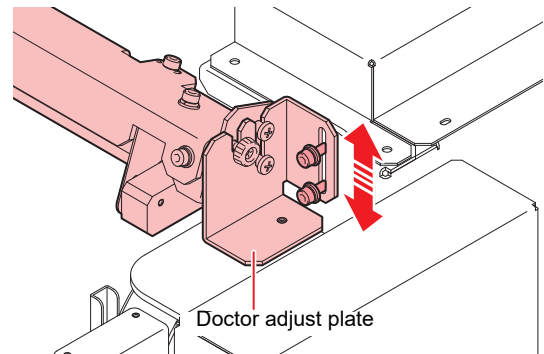

10 Press **▲** **▼** to set the feed speed, and press the **ENTER** key.

11 Pour adhesive (150 to 200cc) uniformly to the backside of the doctor.

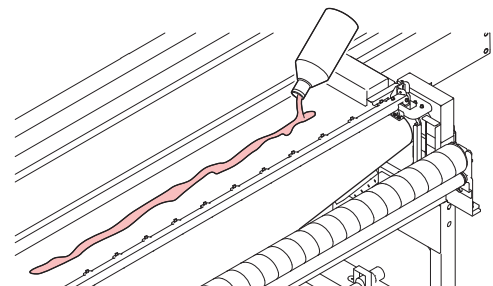

12 Press the **FUNC2** (START) key.

- The feeding belt will move.



- Increase the belt speed when the adhesive is thick.
- Press **FUNC1** (SPEED UP) **FUNC3** (SPEED DOWN) to change the feed speed if desired.
- Press the **FUNC2** (PAUSE) key to suspend the feeding belt.
When restart, press the **FUNC2** (START) key.

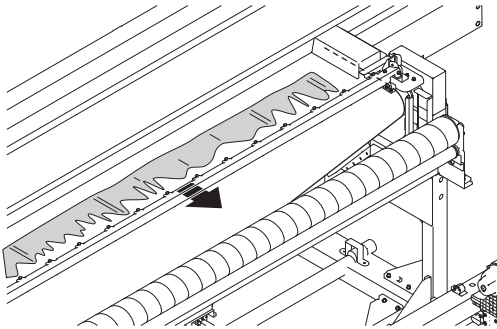

- Add adhesive to areas of the doctor rubber section which have a small amount remaining.
- When doing this, be sure to apply adhesive to the entire belt surface.
- Please use all of the adhesive.

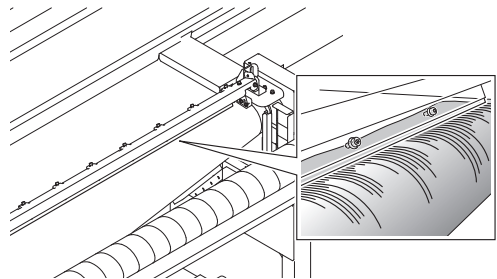

- If the adhesive does not decrease, move the doctor higher little by little and paint the agent thick.

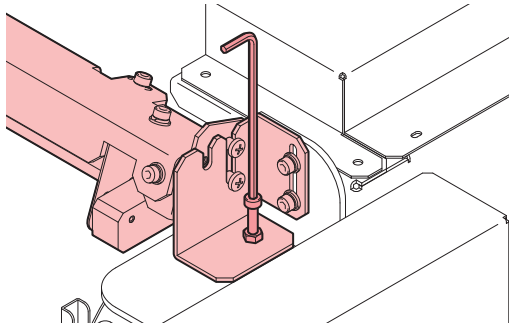

- When you moved up the doctor once, don't get it down in order to avoid making the adhesive roughen.

13

Remove the doctor and clean any adhesive, dirty, or other contaminants using kerosene (diesel oil) and a waste cloth.

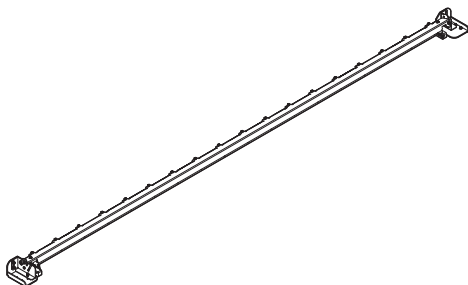

14

Remove the tape places on the sides of the feeding belt.



- When removing the tape, pull it towards the back of the machine. This will allow the adhesive to easily peel from the tape.

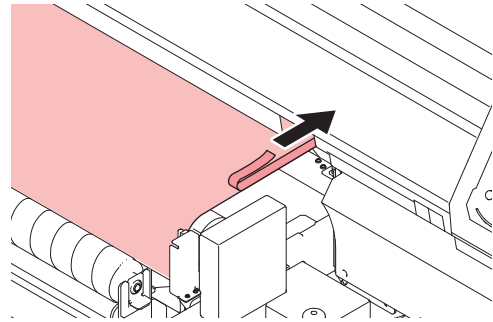

15

Press the **ENTER when setting drying time.**



- When a drying time is set, the feeding belt will automatically stop after the time specified.
- The adhesive counter is reset.

16

Press **▲ **▼** to set the drying time (hours), and press the **ENTER** key.**

17

Press **▲ **▼** to set the drying time (minutes), and press the **ENTER** key.**

- The drying time timer will start.
- To stop drying, press the **END/POWER** key.

18

Once the adhesive applied to the feeding belt has dried, press the **[END] **▶** **ENTER** keys to stop feeding belt operation.**

19

Once the message "Adhesive Counter Reset?" has been displayed, press the **ENTER key.**

- The adhesive counter is reset.

Important!

- When the adhesion is too strong after the adhesive dried, wipe the belt surface with a wet cloth and acclimate the adhesive. Otherwise, using as is, the cloth may not come off.

17 Once the message “Water supply completed.” is displayed, press the **ENTER** key.

18 Press the **ENTER** key.

- The message “The wash unit is returning to standby position. Please wait momentarily” is displayed.
- Once the wash unit has returned to standby position, the replace water setting screen will be displayed.

Feeding Belt Cleaning

The following steps are used to clean the feeding belt.

Important! • Before cleaning the feeding belt, be sure to remove any fabric from the top of the feeding belt.

1 Press **FUNC1 (MENU)** → **▼** → **ENTER** in LOCAL.

• MAINTENANCE MENU will be displayed.

2 Press **▲** **▼** to select “BELT CLEANING”, and press the **ENTER** key

• The belt cleaning setting screen is displayed.

3 Once the message "Remove Media" has been displayed, confirm that there is no fabric on the feeding belt and press the **ENTER** key.

4 Once the message "Raise the Pressure Roller" has been displayed, raise the back roller and then press the **ENTER** key

5 Press **▲** **▼** to set the number of cleanings, and press the **ENTER** key two times.

- Set Value: 1 to 99 times
- Belt cleaning is started. Each belt rotation is counter as one cleaning and will be updated each time a rotation is completed.



- To stop cleaning, press the [END] and then press the [ENTER] key.

6 Once the message "COMPLETED" has been displayed, press the **ENTER** key.

• The maintenance menu is displayed.

Peeling Sensor Cleaning

To prevent misoperation of the peeling sensor due to being dirty, clean the peeling sensor regularly (about once a week).

Important!

- The peeling sensor may be dirty because of ink mist generated during printing and from steam generated when fabric is dried.

In addition, perform cleaning in the following situations.

- The alarm beeps without the fabric being peeled.
- The alarm beeps event when the fabric is not taken up on the belt.

- 1 Use a cotton swab soaked in cleaning solution to clean the reflector.**

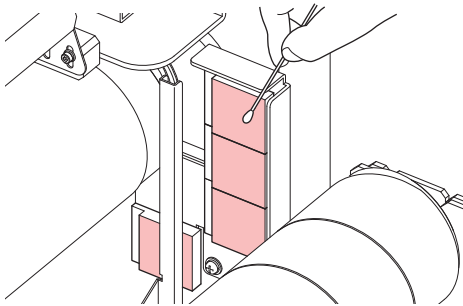

- 2 Clean the reflector cleaned in Step 1 with a dry cotton swab.**

- 3 Clean the light-emitting surface of the peeling sensors (three) with a cotton swab soaked in cleaning solution.**

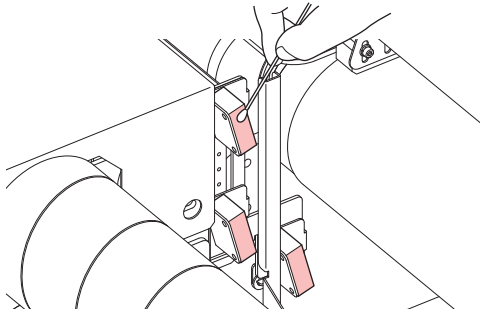

- 4 Clean the lenses cleaned in Step 3 with a dry cotton swab.**

Resetting the Counter

The following steps are used to initialize the adhesive counter and absorb roller counter.

- 1 Press **FUNC1** (MENU) → **ENTER** in LOCAL.**

- MAINTENANCE MENU will be displayed.

- 2 Press **UP** **DOWN** to select “COUNTER RESET”, and press the **ENTER** key**

- The counter reset setting screen is displayed.

- 3 Press **UP** **DOWN** to select “Adhesive” or “Absorb Roller”, and press the **ENTER** key.**

- The counter is reset and the maintenance menu is displayed.

Chapter 5

Troubleshooting



This chapter

describes the corrective measures to be taken for a phenomenon suspected to be trouble and the procedures to clear the error number displayed on the LCD.

Troubleshooting	5-2
Power does not turn on	5-2
The machine does not start printing	5-2
Media get jammed / media is soiled	5-2
Image quality is poor	5-3
Nozzle is clogged	5-3
Ink IC warning appears.....	5-3
When the ink leakage occurs	5-3
Warning / Error Messages	5-4
Warning messages.....	5-4
Error messages	5-8

Troubleshooting

Take appropriate actions as described below before taking the trouble as a failure.

If still the problem is not solved after troubleshooting, contact your dealer or an office of MIMAKI.

Power does not turn on

In most cases, this is due to improper connection of the power cable for the machine or computer. Check that the power cable is connected properly.

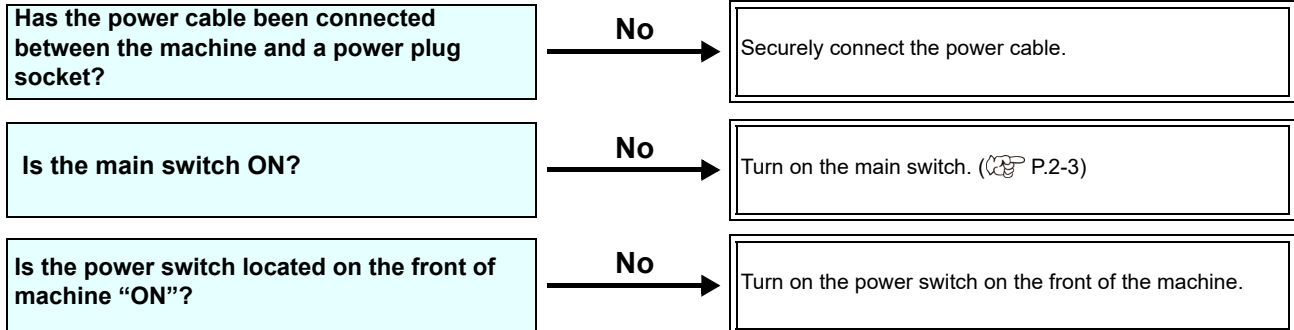

The machine does not start printing

This occurs when the data is not being transmitted to the machine properly.

It can also occur when the printing function does not work properly or the media is not set correctly.

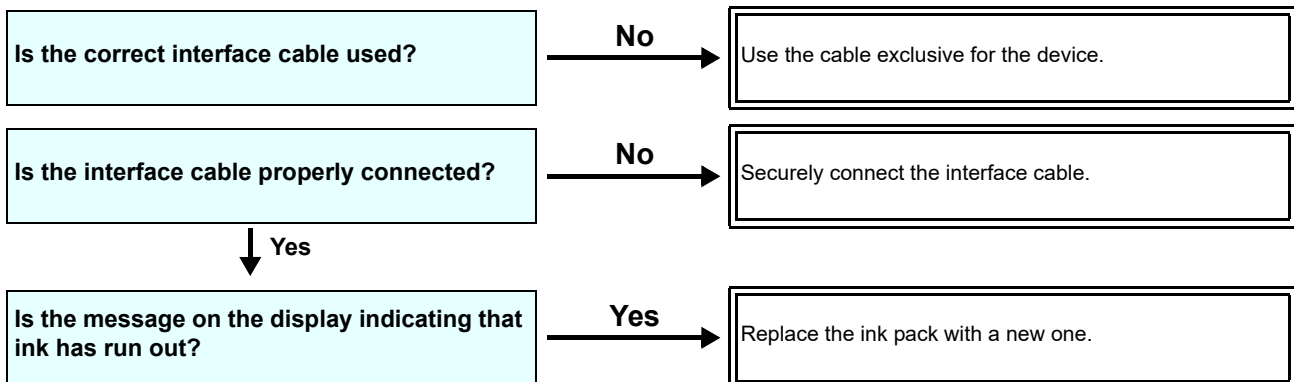

Media get jammed / media is soiled

Media jamming or stained media is considered to be due to the use of an unsuitable media or improper setting of media.

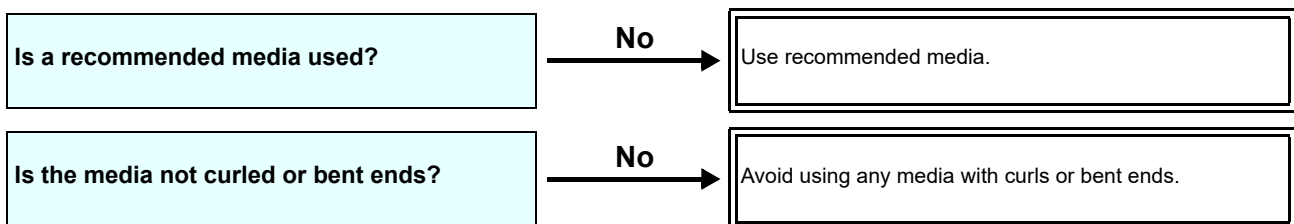

Image quality is poor

This section describes the corrective actions to be taken in case the image quality is not satisfactory.

Take remedy for particular problems with image quality. If the remedy does not work, contact your dealer or an office of MIMAKI.

Phenomenon	Measures
White lines / blur / dark stripes (in the direction of travel of the heads)	<ol style="list-style-type: none"> (1) Execute the head cleaning. (☞ P.2-27) (2) Perform maintenance of the inside of the station. (☞ P.4-6) (3) Execute the [FEED COMP.] function. (☞ P.3-5) (4) If any pieces of paper or dust is attached on the path of the heads such as media press, remove it.
Characters are double- or triple-printed in the media feed direction	<ol style="list-style-type: none"> (1) Execute the [FEED COMP.] function. (☞ P.3-5)
Disagreement in print positions between outward trip and homeward trip	<ol style="list-style-type: none"> (1) Execute the [DROP POSITION] function. (☞ P.3-6)
Ink drops falling on media during printing	<ol style="list-style-type: none"> (1) Execute the wiper cleaning. (☞ P.4-6) (2) Execute the ink cap cleaning. (☞ P.4-6) (3) Clean around the head. (☞ P.4-13) (4) Execute the head cleaning [NORMAL]. (☞ P.2-27) (5) Set the INTERVAL WIPING operation. (☞ P.3-11)

Nozzle is clogged

When nozzle clogging is not dissolved even after the head cleaning referring to P.2-27, make sure the following operations.

- Wash the head nozzle by the operations of P.4-7.
- Wash the head nozzle surface by the operations of P.4-13.
- Recovery the nozzle by the operations of P.4-14.

Ink IC warning appears

If an ink IC trouble is detected, the cartridge LED "red" is lit, and a warning message appears.

None of printing, cleaning and all the other operations that use ink is available.

In this case, replace the ink pack in question immediately.



- Once cartridge trouble is displayed, do not leave the ink pack without replacing it for a long time; otherwise, the machine will lose the nozzle clogging prevention function.

If nozzles are clogged, the machine must be repaired by MIMAKI's service engineer.

Displaying the description of ink IC trouble

The contents of IC error are confirmable by the following operations.

1 Press the **ENTER** key in LOCAL.

2 Press the **ENTER** key.

When the ink leakage occurs

In case of ink leakage, please turn off the main power, unplug the power cable and contact your local distributor, our sales office, or service center.

Warning / Error Messages

If some trouble occurs, the buzzer sounds and the display shows a corresponding error message. Take an appropriate remedy for the displayed error.

Warning messages

Errors when performing operations

Message	Cause	Solution
INVAILD OPERATION :MEDIA UNDETECT	Operation cannot be performed because no media is detected.	<ul style="list-style-type: none"> Execute after media is detected.
INVAILD OPERATION :MOTOR POWER OFF	The motor is OFF after the cover was opened etc.	<ul style="list-style-type: none"> Return to LOCAL and execute the operation after completion of initialization.
INVAILD OPERATION INK ERROR	An ink error occurred.	<ul style="list-style-type: none"> Execute the operation after replacing with a new ink pack.
INVAILD OPERATION COVER OPEN	The front cover or the maintenance cover is opened.	<ul style="list-style-type: none"> Execute the operation after closing the cover.
INVAILD OPERATION DATA REMAIN	Data was received.	<ul style="list-style-type: none"> Execute the operation after executing data clear. (☞ P.2-29)
INVAILD OPERATION EMERGENCY SWITCH	The emergency stop switch was pressed.	<ul style="list-style-type: none"> Release the emergency stop switch to return to normal function.
INVAILD OPERATION WASH UNIT ORG.	The origin of the belt wash unit cannot be detected.	<ul style="list-style-type: none"> Turn off the power on the machine and turn it on after a while. When displaying again, contact your local distributor, our sales office, or service center.

Message displayed in LOCAL

Message	Cause	Solution
Can't print/cartridge	Multiple ink errors (unusable ink) have occurred, making it impossible to feed ink (printing and cleaning, etc.).	Replace with a new ink pack.
Check waste ink	The waste ink tank count has exceeded the prescribed amount.	Check the amount of waste ink in the waste ink tank. Conduct maintenance and waste ink tank replacement, and reset the amount of waste ink.
Replace WIPER	The used count of wiper has exceeded the prescribed number.	Execute maintenance, station maintenance and wiper exchange and replace the wiper.
DATA REMAIN	Print data is received in LOCAL.	Shift to REMOTE and execute printing. Or, execute data clear and cancel printing.
MACHINE TEMP./H ***°C	Stable printing cannot be done because temperature in the installed environment (printer) is too high.	Adjust the ambient temperature to within the specified scope (20°C to 35°C).
MACHINE TEMP./L ***°C	Stable printing cannot be done because temperature in the installed environment (printer) is too low.	

Message	Cause	Solution
Wash liquid cartridge none	The maintenance washing liquid cartridge is not set. Wiper washing and pump tube washing cannot be executed. (Auto maintenance operation)	Set the maintenance washing liquid cartridge.
Wash liquid end	There is no remaining maintenance washing liquid. Wiper washing and pump tube washing cannot be executed. (Auto maintenance operation)	Replace with a new washing liquid cartridge.
NCU SENSOR LEVEL LOW	The NCU sensor sensitivity is falling.	Replacement of the NCU is recommended. Contact your local distributor, our sales office, or service center.
NCU Sens Adj Err H	The sensitivity level of the sensor cannot be adjusted.	
NCU Sens Adj Err L		
Nozzle Missing Print Stopped	Because the nozzle check found nozzles missing, printing was stopped.	Perform head cleaning (☞ P.2-27) and deal with the nozzles clogging (☞ P.5-3).
NCU FLUSH POS Nozzle check OFF	Because an NCU-related error occurred during nozzle check, printing was stopped and the nozzle check function was turned OFF.	• Check the state of the nozzles, and if there are frequent nozzle missing and ink droplet misalignment, conduct cleaning to restore.
NCU SN ADJUST Nozzle check OFF		• Check the state of the nozzles, and if there are frequent nozzle missing and ink droplet misalignment, conduct cleaning to restore. If the same error message still appears after restoring the state of the nozzles, contact your local distributor, our sales office, or service center.
NCU CENTER POS Nozzle check OFF	The NCU sensor sensitivity is too low to correctly judge nozzle missing. The nozzle check function cannot be used.	• Check the state of the nozzles, and if there are frequent nozzle missing and ink droplet misalignment, conduct cleaning to restore.
NCU NZK CHK (HW) Nozzle check OFF		
NCU NZK CHK (MARK) Nozzle check OFF		
NCU CONNECT	The NCU unit is not connected. The nozzle check function cannot be used.	• Turn off the power on the machine and turn it on after a while. If the same error message appears, contact your local distributor, our sales office, or service center.
REPLACE NCU	The NCU sensor sensitivity is too low to correctly judge nozzle missing. The nozzle check function cannot be used.	• NCU replacement is necessary. • Contact your local distributor, our sales office, or service center.
REPLACE NCU INK PAD	The NCU ink pad is full.	• It is necessary to replace the NCU ink pad. • Contact your local distributor, our sales office, or service center.
NCU ERROR Nozzle check OFF	Because an NCU-related error occurred during nozzle check, printing was stopped and the nozzle check function was turned OFF.	• Contact your local distributor, our sales office, or service center.
ADJUST HEAD HEIGHT	The head height setting saved in the machine and the current head height do not match.	• Set the head height. (☞ P.2-5)

Message	Cause	Solution
Replace the spout rubber - of ECO-CARTRIDGES	It is time to replace spout rubber of the eco-case (MBIS).	<ul style="list-style-type: none"> Ink may leak from the eco-case. Replace spout rubber.
Please check Motor direct-connect unit	Installation of the direct-connection unit/ torque limiter is incorrect in relation to the settings of the feeding/take-up tension bar.	<ul style="list-style-type: none"> To use tension bar, install direct-connection unit. If not using the tension bar, install torque limiter.
Close cover	Cover is open.	<ul style="list-style-type: none"> Execute the operation after closing the cover.
Release a switch	The emergency stop switch was pressed.	<ul style="list-style-type: none"> Release the emergency stop switch to return to normal function.
Check The Absorb Roller	It is time to check absorb roller water supply amount.	<ul style="list-style-type: none"> Clean the absorb roller. (☞ P.4-24) After cleaning has been completed, reset the maintenance counter and absorb roller counter.
Belt Adhesive 200m To Go	The adhesive needs to be replaced soon.	<ul style="list-style-type: none"> Reapply new adhesive. (☞ P.4-28) After new adhesive has been applied, reset the maintenance counter and adhesive counter.
Reapply Belt Adhesive	It is time to replace the adhesive.	
Lower the Pressure Roller	The pressure roller rises when printing starts.	
Raise the Pressure Roller	The pressure roller rises when the power is turned off and during belt cleaning.	
PEEL UNIT ERROR Check and reset the media to correct position	A peeling sensor error has occurred.	<ul style="list-style-type: none"> If media is trapped in the machine, remove it manually. Use the winding motor switch to wind the peeled media.
Please supply water	Printing stopped because the washing water in the washing unit was insufficient during printing.	<ul style="list-style-type: none"> Supply water into the washing unit.
Replace water in the wash unit	One week passed after the last exchange of washing water.	<ul style="list-style-type: none"> Discharge and supply the washing water in the washing unit.

Ink Error

Ink error is displayed also in the local guidance. (☞ P.3-28)

Message	Cause	Solution
WRONG INK IC	The IC chip of the ink pack cannot be read normally.	<ul style="list-style-type: none"> Remove the ink IC chip generating the warning once and install it again. If the same error message appears, arrange a service call with our service desk or your local distributor.
INK TYPE	The ink of the ink pack is different in type from the ink currently supplied.	<ul style="list-style-type: none"> Check the ink type of the cartridge generating the warning.
INK COLOR	The ink of the ink pack is different in color from the ink currently supplied.	<ul style="list-style-type: none"> Check the ink color of the cartridge generating the warning.
WRONG CARTRIDGE	An error occurred in the IC chip information of the ink pack.	<ul style="list-style-type: none"> When MBIS or BS ink is used: Replace the IC chip. (Be sure to also replace the chip when replacing ink packs.) When any type of ink is used: Make sure there is no nozzle clogging. (especially when white ink is used.)
NO CARTRIDGE	An IC chip has not been installed in the slot.	<ul style="list-style-type: none"> Install an appropriate ink IC chip in the slot generating the warning.
INK END	The ink of the ink pack has been completely used up.	<ul style="list-style-type: none"> Replace the ink pack generating the warning with a new one.
INK NEAR END	There is only a little bit of ink left in the ink pack.	<ul style="list-style-type: none"> The ink will soon be used up. Be careful.
Expiration	The ink of the ink pack has been nearly used up.	<ul style="list-style-type: none"> Replace the cartridge generating the warning with a new one. However, it can be used until the month after next.
Expiration:1MONTH	The specified expiration date of an ink pack has passed.	<ul style="list-style-type: none"> The expiration date has passed. However, you can use it until the end of the following month.
Expiration:2MONTH	The expiration date of an ink pack has passed (one month has passed after the specified expiration date).	<ul style="list-style-type: none"> One month has passed after the expiration date.

Error messages

When an error message is displayed, eliminate the error according to the chart below.
When displaying again, contact your dealer or an office of MIMAKI to call for service.

Message	Cause	Solution
ERROR 108 HD THERMIS[1234]	Head temperature control is defective.	<ul style="list-style-type: none"> • Turn off the power on the machine and turn it on after a while. When displaying again, contact your local distributor, our sales office, or service center.
ERROR 108 HD CONNECT1234]	An abnormality occurred in the head connection.	
ERROR 122 CHECK:SDRAM	SDRAM is defective.	
ERROR 128 HDC FIFO OVER	Head control circuit board is defective.	
ERROR 128 HDC FIFO UNDER		
ERROR 129 BATTERY EXCHANGE	The battery life end of the internal clock is detected.	
ERROR 12a HDC SPEED	An error was detected in the waveform being printed.	
ERROR 130 HD DATA SEQ		
ERROR 148 E-LOG SEQ	Log control is defective.	
ERROR 151 Main PCB V1R2	Error occurs in the power supply system of the main board.	
ERROR 152 Main PCB V2R5		
ERROR 153 Main PCB V3R3		
ERROR 154 Main PCB V05		
ERROR 157 Main PCB VTT		
ERROR 16e Main PCB V3R3B		
ERROR 18a Main PCB V_CORE		
ERROR 18c Main PCB V12		
ERROR 15f HEAD DRIVE HOT		
ERROR 171 NEW HEAD CONNECT	A new head connection was detected.	

Message	Cause	Solution
ERROR 18e FLS NOT COMP	An error was detected in the waveform being printed.	<ul style="list-style-type: none"> • Turn off the power on the machine and turn it on after a while. When displaying again, contact your local distributor, our sales office, or service center.
ERROR 18f OFFSET START		
ERROR 18f OFFSET END		
ERROR 1ce SLIDER PCB V24	An error occurred in the power supply of the slider PCB.	
ERROR 1cf SLIDER PCB V1R8		
ERROR 1d9 Main PCB V48-1	An error occurred in the main PCB.	
ERROR 1db Station4 PCB V48	An error occurred in the power supply of the first Station IV PCB.	
ERROR 1dc Station4 PCB V24		
ERROR 1dd Station4 PCB V24-A		
ERROR 1db Station4-2 PCB V48	An error occurred in the power supply of the second Station IV PCB.	
ERROR 1dc Station4-2 PCB V24		
ERROR 1dd Station4-2 PCB V24-A		
ERROR 1db Station4-3 PCB V48	An error occurred in the power supply of the third Station IV PCB.	
ERROR 1dc Station4-3 PCB V24		
ERROR 1dd Station4-3 PCB V24-A		
ERROR 1de SLIDER PCB V1R2	An error occurred in the power supply of the slider PCB.	
ERROR 1df SLIDER PCB V2R5		
ERROR 1e0 SLIDER PCB V3R3		
ERROR 1e1 SLIDER PCB V5		
ERROR 1e2 SLIDER PCB V48		
ERROR 1e6 PRAM SIZE SHORTAGE		The memory size is insufficient.

Message	Cause	Solution
ERROR 201 COMMAND ERROR	The machine received some data other than print data. Or, an error occurred in the transmitted print data.	<ul style="list-style-type: none"> • Clear the data, and then send the data again. • Turn the power off and on again, and then send the data.
ERROR 202 PARAMETER ERROR	An error occurred in the transmitted print data.	<ul style="list-style-type: none"> • Securely connect the interface cable in position. Use an interface cable conforming to the specifications.
ERROR 206 PRINTING MODE	Unable to print with the printing conditions of the print data received.	<ul style="list-style-type: none"> • Check the output conditions of the print data in the RIP software. • Check the profile. • When displaying again, contact your local distributor to call for service.
ERROR 304 USB INIT ERR	An error occurred in the communication of USB.	<ul style="list-style-type: none"> • Turn the power off and on again, and then send the data. • Make sure the interface cable is connected securely. Use an interface cable that conforms to the industry standards.
ERROR 305 USB TIME OUT		
ERROR 307 MCFD File IF Error	An error occurred during the access to the printing condition data.	<ul style="list-style-type: none"> • Turn off the power on the machine and turn it on after a while. When displaying again, contact your local distributor, our sales office, or service center.
ERROR 401 MOTOR X	An excessive load was applied to the X motor.	<ul style="list-style-type: none"> • Check the loading status of the media. (Make sure it can be fed without error.) • Open the cover, and then check that nothing is obstructing the carriage movement. • Turn off the power on the machine and turn it on after a while. When displaying again, contact your local distributor, our sales office, or service center.
ERROR 403 X CURRENT	An error due to an excessive current of the X motor was detected.	<ul style="list-style-type: none"> • Turn off the power on the machine and turn it on after a while. When displaying again, contact your local distributor, our sales office, or service center.
ERROR 402 MOTOR Y	An excessive load was applied to the Y motor.	
ERROR 404 Y CURRENT	An error due to an excessive current of the Y motor was detected.	
ERROR 424 FEEDING TENSION-BAR	<p>Error in the take-up tension bar.</p> <ul style="list-style-type: none"> • The tension bar origin could not be found. • No change could be seen in the tension bar angle. 	<ul style="list-style-type: none"> • Check the set state of the media. • Make sure that the media can be wound using the manual SW. Also, make sure that the tension bar rises. If it does not rise, adjust the counterweight. (P.2-18)
ERROR 426 Feeding WRONG	<p>A problem has occurred in the feeding tension bar.</p> <ul style="list-style-type: none"> • The tension bar control position has deviated from the lowest point for a certain period. 	<ul style="list-style-type: none"> • Check the set state of the media. • Make sure that the media can be wound using the manual SW. Also, make sure that the tension bar rises. If it does not rise, adjust the counterweight. (P.2-18)
ERROR 42A Feeding LimitDETECT	<p>LIMIT position of the tension bar has been detected.</p> <ul style="list-style-type: none"> • The tension bar control position has deviated from the highest point for a certain period. 	<ul style="list-style-type: none"> • Check the set state of the media. • Make sure that the media can be wound using the manual SW. Also, make sure that the tension bar rises. If it does not rise, adjust the counterweight. (P.2-18)

Message	Cause	Solution
ERROR 44f Take-UP Roll Sns Err	Roller sensor abnormality • The roller sensor cannot be correctly read.	<ul style="list-style-type: none"> • Confirm that the take-up unit of machine setup and take-up tension bar setting are ON. (☞ P.2-4) • Check the set state of the media. • Confirm that the winding unit operates using the manual SW.
ERROR 450 Feeding Roll Sns Err	Feed sensor error. • The feed sensor could not be read correctly.	<ul style="list-style-type: none"> • Check that feeding unit in machine setup are set to "ON". • Check how the media is set. • Check by Manual SW that feeding device can operate.
ERROR 459 GRIPORG UNDETECTED	Cannot detect the start point of the grip section for the correction unit.	<ul style="list-style-type: none"> • Check that the [Settings] - [Belt Correction] is set to on. • Turn off the main power supply, wait for a while, and then turn the power back on. • If the message is displayed again, contact your local distributor, our sales office, or service center.
ERROR 472 DISPLACEMENT SNS ORG.	Cannot detect the start point of the displacement sensor for the correction unit.	<ul style="list-style-type: none"> • Clean up the adhesive stuck at the right edge of the feeding belt. • Clean up the adhesive stuck at the grip rubber of the belt correction unit. (☞ P.4-3 "Cleaning the Belt Correction Unit") • When it occurs frequently, call our service center or the distributor.
ERROR 473 GRIP SLIP	At the time of feeding, the origin of the grip part of the correction unit is not off. Or a displacement sensor does not react.	<ul style="list-style-type: none"> • Turn off the main power supply, wait for a while, and then turn the power back on. • If the message is displayed again, contact your local distributor, our sales office, or service center.
ERROR 475 BELT COMP. ERROR	The value of the displacement sensor on the belt correction unit is wrong.	<ul style="list-style-type: none"> • Wind the media manually, and make sure that the media is not on the peel sensor. • Check that the rotation switch of the rewind motor is set to the correct direction. • If the message is displayed again, contact your local distributor, our sales office, or service center.
ERROR 46d WASH BRUSH ORG.	Cannot detect the start point of the cleaning unit.	<ul style="list-style-type: none"> • Make sure that the media can be peeled off equally on the left and right. • Check that the rotation switch of the rewind motor is set to the correct direction. • Peel off the media manually, and then wind by using the winding switch.
ERROR 46f PEEL SENSOR	Failed to detect the peel sensor (slack sensor).	<ul style="list-style-type: none"> • Check that the media has not rolled up around the cleaning unit. • Check that the rotation switch of the rewind motor is set to the correct direction. • Peel off the media manually, and then wind by using the winding switch.
ERROR 470 PEEL UNIT WARN	Error during peel unit operation (Sensor ON/OFF detect continuously).	<ul style="list-style-type: none"> • Turn off the power on the machine and turn it on after a while. • When displaying again, contact your local distributor, our sales office, or service center.
ERROR 471 CAN'T PEEL MEDIA	Detect peel sensor EM (lowest sensor)	<ul style="list-style-type: none"> • Remove the media and reset it. • Open the cover, and then check that nothing is obstructing the carriage movement.
ERROR 509 HDC POSCNT	An error occurred in the control position.	
ERROR 50a Y ORIGIN	The Y start point detection (initialization operation) is defective.	
ERROR 50f L-SCALE BLACK	Abnormal linear scale.	
ERROR 505 MEDIA JAM	The media jam occurs.	

Message	Cause	Solution
ERROR 528 PUMP MOTOR SENSOR	Pump sensor detection error	<ul style="list-style-type: none"> • Turn off the power on the machine and turn it on after a while. If the same error message appears, contact your local distributor, our sales office, or service center.
ERROR 52f CARRIAGE ORG	The carriage control origin is not set.	
ERROR 530 STATION ORG	The station control origin is not set.	
ERROR 536 STATION LOCK	An error was detected in station operation.	
ERROR 537 MAINT.WASH SHUTTER	An error was detected in cleaning solution shutter operation.	
ERROR 53e WASH LIQ. OVERFLOW	The water in the belt cleaning tray is full.	<ul style="list-style-type: none"> • Adjust the amount of inflow cleaning water. • Check that the outflow for the cleaning water is not blocked.
ERROR 53f CHECK WASH LIQ.	Not enough water in the belt cleaning tray.	<ul style="list-style-type: none"> • Add water to the belt cleaning tray.
ERROR 602 CARTRIDGE END	Ink end (cannot be used, can only be used when cleaning with the 4-color ink set)	<ul style="list-style-type: none"> • Replace with new ink.
ERROR 608 WRONG INK IC	The ink pack IC chip cannot be correctly read.	<ul style="list-style-type: none"> • Make sure that the cartridge is ink IC chip inserted. • Reinsert the ink IC chip. • Turn off the power on the machine and turn it on after a while. If the same error message appears, contact your local distributor, our sales office, or service center.
ERROR 627 RE-INSERT CARTRIDGE	No cartridge set. (Not set for the specified period)	<ul style="list-style-type: none"> • Set the cartridge. • Check that the cartridge is installed correctly.
ERROR 628 WRONG INK CARTRIDGE	A problem has occurred in the ink pack IC chip information. The used count has exceeded the prescribed value.	<ul style="list-style-type: none"> • When using MBIS/BS ink. Replace the IC chip. (Make sure you replace the chip as well as replacing the pack.) • Common Check that the nozzles are not blocked. (Especially the white ink nozzle.)
ERROR 650 NCU CONECT	The NCU unit is not connected.	<ul style="list-style-type: none"> • Turn off the power on the machine and turn it on after a while. If the same error message appears, contact your local distributor, our sales office, or service center.
ERROR 651 REPLACE NCU	The NCU sensor sensitivity is too low to correctly judge nozzle missing. The nozzle check function cannot be used.	<ul style="list-style-type: none"> • The NCU needs to be replaced. Contact your local distributor, our sales office, or service center.
ERROR 652 NCU NZK CHK (HW)	The NCU cannot correctly recognize the ink discharge, because there are frequent nozzle missing and ink droplet misalignment.	<ul style="list-style-type: none"> • Check the state of the nozzles, and if there are frequent nozzle missing and ink droplet misalignment, conduct cleaning to restore.
ERROR 653 NCU NZK CHK (MARK)		
ERROR 654 NCU CENTER POS	Adjustment of the discharge position to the NCU has failed.	
ERROR 655 NCU FLUSH POS		

Message	Cause	Solution
ERROR 656 NCU SN ADJUST	Sensor sensitivity adjustment has failed.	<ul style="list-style-type: none"> Check the state of the nozzles, and if there are frequent nozzle missing and ink droplet misalignment, conduct cleaning to restore. If the same error message still appears after restoring the state of the nozzles, contact your local distributor, our sales office, or service center.
ERROR 657 REPLACE NCU INK PAD	The NCU ink pad is full.	<ul style="list-style-type: none"> Replace the NCU ink absorber. Contact your local distributor, our sales office, or service center.
ERROR 658 NCU SENSOR LV LOW	THE sensitivity level of the NCU sensor is low.	<ul style="list-style-type: none"> Replacement of the NCU is recommended. Contact your local distributor, our sales office, or service center.
ERROR 65b NCU Sens Adj Err H	The sensitivity level of the sensor cannot be adjusted.	
ERROR 65c NCU Sens Adj Err L		
ERROR 901 INVALID OPERATION	Due to a certain error, the function cannot be performed.	<ul style="list-style-type: none"> Close the cover before performing the operation. Make sure the media has been detected before performing the operation. Clear the ink error before performing the operation.
ERROR 902 DATA REMAIN	There remains received data that has not yet been printed.	<ul style="list-style-type: none"> Clear the data before performing the operation.
ERROR 90d NO HEAD SELECT	An error occurred in the mounted heads.	<ul style="list-style-type: none"> Turn off the power on the machine and turn it on after a while. When displaying again, contact your local distributor, our sales office, or service center.
ERROR 90f PRINT AREA SHORT	The media width or the media length required for printing is not enough.	<ul style="list-style-type: none"> Change the media to the one with enough width or length. When the media width narrows because the origin moved, slide the origin to the right to widen the effective media width.
ERROR 04 PARAM ROM	An error occurred in the main PCB FROM.	<ul style="list-style-type: none"> Turn off the power on the machine and turn it on after a while. When displaying again, contact your local distributor, our sales office, or service center.
ERROR 91a ADJUST HEAD HEIGHT	The head height setting saved in the machine and the current head height do not match.	<ul style="list-style-type: none"> Set the head height. (☞ P.2-5)
ERROR D01 HCB POWER [1234]	An error occurred in the power supply of the HCB PCB.	<ul style="list-style-type: none"> Turn off the power on the machine and turn it on after a while. When displaying again, contact your local distributor, our sales office, or service center.
ERROR D02 HCB COMMON [1234]	An error was detected in the HCB PCB.	
ERROR D03 HCB HARD [1234]		
ERROR D04 HCB CMD [1234]	An error was detected in the HCB PCB communication.	
ERROR D05 HCB WFM [1234]	Printed output waveform is defective.	
ERROR D06 HCB VUP [1234]	A failure to update the HCB PCB was detected.	

Message	Cause	Solution
ERROR D07 HCB FAN [1234]	An error occurred in the HCB board fan.	<ul style="list-style-type: none"> Turn off the power on the machine and turn it on after a while. When displaying again, contact your local distributor, our sales office, or service center.
ERROR D08 HCB UKNWN [1234]	An unknown error was detected from the HCB board.	
ERROR D09 HD MEMORY [1234]	An abnormality was detected from the head built-in memory.	
ERROR D0A HCB BUSY [1234]	An error occurred in the communication between the HCB board and the slider P board.	

SYSTEM HALT

Message	Solution
SYSTEM HALT (*) 000 : MESSAGE	<ul style="list-style-type: none"> Turn off the power on the machine and turn it on after a while. When displaying again, check the number and contact your local distributor, our sales office, or service center. ("000" is the error No.)
SYSTEM HALT (*) 406 : WIPER ORG	<ul style="list-style-type: none"> Perform cleaning around the wiper. Turn off the power on the machine and turn it on after a while. When displaying again, check the number and contact your local distributor, our sales office, or service center.

Chapter 6

Appendix



This chapter

contains the lists of the specifications and functions of this machine.

- Specifications6-2
 - Machine specifications 6-2
 - Ink specifications 6-3
- Setting orders depending on ink type6-4
 - Setting orders of ink cartridges 6-4
- Sheet for inquiry6-5

Specifications

Machine specifications

Item		Tx300P-1800B
Print head	Method	Drop-on-demand piezoelectric print heads
	Specification	4-Head Inline
Printing mode (scan x feed)		540×360dpi/ 540×540dpi/ 540×720dpi/ 720×720dpi/ 720×1080dpi/ 720×1440dpi ^{*1}
Usable inks		Sublimation dye ink: Sb420, Sublimation dye ink: Sb421, Pigment ink for textile: TP400, Disperse dye ink: Dd400, Acid-dye ink: Ac400, Reactive-dye ink: Rc400, Rc500
Ink supply		Supplying from ink packs through tubes. Ink pack replacement type: Supplying by Toggle switch over with 2 packs/color (4-colors ink set/ 6-colors ink set: M, BI)
Capacity of ink pack	4-colors	Y, M, BI, K (Sb420): 2L ink pack 2L-ink pack x 2 for each color
		Y, M, BI, K (Sb421): 2L ink pack 2L-ink pack x 2 for each color
		Y, M, C, K (TP400): 2L ink pack 2L-ink pack x 2 for each color
	6-colors	Y, K, LBI, Lm: 2L-ink pack x 1 for each color
		M, BI: 2L-ink pack x 2 for each color
	7-colors	M, R, BI, C, Y, Lk: 2L-ink pack x 1 for each color K: 2L-ink pack x 2
	8-colors	M, R, C, Gr, Y, K, V, P (Dd400): 2L-ink pack x 1 for each color
		M, R, BI, C, Y, Or, K, Lk (Ac400): 2L-ink pack x 1 for each color
		M, R, BI, C, Y, Or, K, Lk (Rc400): 2L-ink pack x 1 for each color
		M, R, BI, C, Y, Or, K, Lk (Rc500): 2L-ink pack x 1 for each color
4 + 4-colors	Y, M, BI, K (Sb420): 2L ink pack 2L-ink pack x 2 for each color Y, M, C, K (TP400): 2L ink pack 2L-ink pack x 2 for each color	
	Y, M, BI, K (Sb421): 2L ink pack 2L-ink pack x 2 for each color Y, M, C, K (TP400): 2L ink pack 2L-ink pack x 2 for each color	
Usable media		Polyester, cotton, silk etc.
Max. printing width		1,880mm (74.0 in)
Roll Media size	Maximum	1,900mm (74.8 in)
	Minimum	210mm (8.3 in)
	Thickness	1.0mm or less (0.039 in or less)
	Roll outside diameter ^{*2}	Φ250mm or less (Φ9.8 in or less)
	Roll weight ^{*1, *3}	40 kg (88.2 lb) or less (for 2 to 3 inch rolls) 34 kg (75.0 lb) or less (for 1 to 1.5 inch rolls)
	Roll inside diameter	1 to 1.5 inch, 2 to 3 inch
	Printing surface	Regardless of faces in and out
	Roll end treatment	The roll end is gently fixed to the core with weak-adhesive tape or weak glue for easy removal.
Leaf media size	Maximum	1,900mm (74.8 in)
	Minimum	210mm (8.3 in)
Margin	Leaf media	Left end and right end: 20 mm (Default) Front: 120 mm Rear: 150 mm (Left end and right end: 0.79 in (Default) Front: 4.72 in Rear: 5.91 in)
	Roll media	Left end and right end: 20 mm (Default) Front: 140 mm Rear: 170 mm (Left end and right end: 0.79 in (Default) Front: 5.51 in Rear: 6.69 in)
Distance accuracy	Absolute accuracy	Whichever the larger one of ± 0.3 mm or ± 0.3 % of the designated (Whichever the larger one of ± 0.012 in or ± 0.3 % of the designated)
	Reproducibility	Whichever the larger one of ± 0.2 mm or ± 0.1 % of the designated (Whichever the larger one of ± 0.008 in or ± 0.1 % of the designated)
Perpendicularity		± 0.5 mm / 1,000 mm (± 0.02 in / 39.4 in)
Media skew		5 mm or less / 10 m (0.2 in or less / 32.8 ft)
Head height adjustment		2 mm to 7 mm, can be freely adjusted manually (0.079 in to 0.28 in, can be freely adjusted manually)
Media delivery		Take-up device supplied as a standard accessory (switching possible between face in and face out).

Item		Tx300P-1800B
Waste ink tank		Bottle type (2,000 cc)
Interface	Print data transmission function	USB 2.0, Ethernet 1000BASE-T
	Mail function	Ethernet 10 BASE-T / 100 BASE-TX / 1000BASE-T
Command		MRL- IV
Noise	during standby	Less than 58 dB (A) (FAST-A, Front & Rear & Left & Right 1 m (39.4 in))
	during continuous printing *4	Less than 65 dB (A)
	during discontinuous printing	Less than 70 dB (A)
Safety Standard		VCCI-Class A, FCC-Class A, UL 60950, CE Marking (EMC, Low Voltage Directive, Machinery Directive, RoHS Directive), CB Report, RoHS
Power		Machine: AC100 - 120V/ 200 - 240V 12A/8A 50/60Hz
Power consumption		Machine: 1440W(AC100 - 120V), 1920W (AC 200 - 240V)
Recommended Environment	Available temp.	20 °C to 30 °C (68 °F to 86 °F)
	Humidity	35 to 65% Rh (No condensation)
	Guaranteed temp.	20 °C to 25 °C (68 °F to 77 °F)
	Temperature change	± 10 °C / h or less (± 50 °F / h or less)
	Dust	Equivalent to normal office level
	Highest operation height	2,000 m (6,561.7 ft)
Weight		627 kg (1,382.3 lb)
Outside dimensions	Width	3,183 mm (125.32 in)
	Depth	1,912 mm (75.28 in)
	Height	1,844 mm (72.6 in)

*1. The available printing modes differ depending on the type of ink to be used.

*2. It is outside diameter and weight after take-up media.

*3. Without deflection of the roll when it is retained at both ends.

*4. Operating Condition: Full load Measuring Method: According to clause 1.7.4.2 of Machinery Directive 2006/42/EC

Ink specifications

Item	Sublimation dye ink Sb420	Sublimation dye ink Sb421	Pigment ink for textile TP400	Disperse dye ink Dd400	Acid-dye ink Ac400	Reactive-dye ink Rc400	Reactive-dye ink Rc500
Supply	2 liters ink pack						
Color	Black (K) Blue (Bl) Magenta (M) Yellow (Y) Light blue (LBl) Light magenta (Lm)		Black (K) Cyan (C) Magenta (M) Yellow (Y) Red (R) Blue (Bl) Light black (Lk)	Black (B) Cyan (C) Magenta (M) Yellow (Y) Red (R) Gray (Gr) Violet (V) Pink (P)		Black (K) Cyan (C) Blue (Bl) Magenta (M) Yellow (Y) Orange (Or) Red (R) Light black (Lk)	
Ink capacity	2 liters						
Shelf life	The period is printed on the ink pack. Within three months after opening the package even in the available period.						
Storage temperature	Storage	Average daily temperature: 10 to 35°C (50 to 95°F) Be sure to keep a vessel in the airtight condition. Be sure to keep a vessel in a dry, well-ventilated, cool and dark location.					
	Transportation	0 to 40°C (32 to 104°F) Avoid the condition lower than -0 °C (32 °F) and higher than 40 °C (104 °F).					



- Do not disassemble ink packs and 2L eco-case and do not refill them with ink.
- Ink could freeze if kept in a cold place for an extended period.
- When aqueous ink is used, if the ink freezes, the quality is changed and the ink becomes unusable. Store the ink in an environment that will not freeze the ink.

Setting orders depending on ink type

The setting value and the setting orders of the ink cartridges differ depending on the ink type you use.

Setting orders of ink cartridges

The orders of ink cartridges set in the ink station differ depending on the ink set you use.



- Set the ink cartridge according to the cartridge label under the ink station.

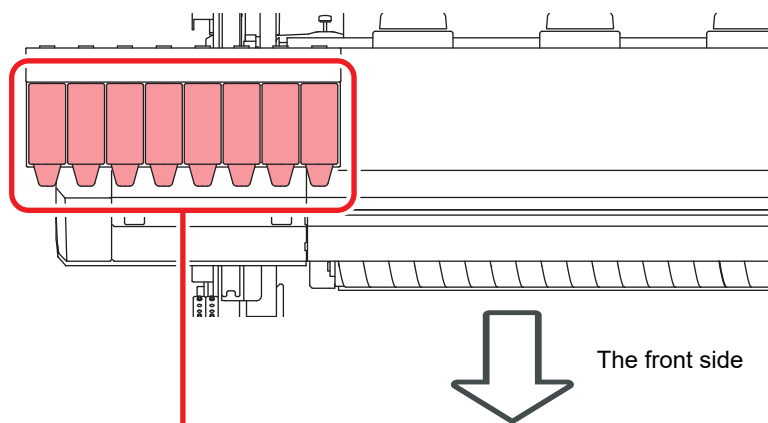

4-colors model	Sublimation dye ink: Sb420	M	M	Bl	Bl	Y	Y	K	K
	Sublimation dye ink: Sb421	M	M	Bl	Bl	Y	Y	K	K
	Pigment ink for textile: TP400	M	M	C	C	Y	Y	K	K
6-colors model	Sublimation dye ink: Sb420	M	M	Bl	Bl	Y	K	LBl	Lm
	Sublimation dye ink: Sb421	M	M	Bl	Bl	Y	K	LBl	Lm
7-colors model	Pigment ink for textile: TP400	M	R	Bl	C	Y	Lk	K	K
8-colors model	Disperse dye ink: Dd400	M	R	C	Gr	Y	K	V	P
	Acid-dye ink: Ac400	M	R	Bl	C	Y	Or	K	Lk
	Reactive-dye ink: Rc400	M	R	Bl	C	Y	Or	K	Lk
	Reactive-dye ink: Rc500	M	R	Bl	C	Y	Or	K	Lk
4 + 4-colors model	Sublimation dye ink: Sb420 Pigment ink for textile: TP400	Sb420				TP400			
		M	Bl	Y	K	M	C	Y	K
	Sublimation dye ink: Sb421 Pigment ink for textile: TP400	Sb421				TP400			
		M	Bl	Y	K	M	C	Y	K

Sheet for inquiry

Use this sheet for troubles and abnormal functions of the machine.
Fill in the following necessary items, and then fax the sheet to our sales office.

Company name	
Person in charge	
Telephone number	
machine model	
Operating OS	
Machine information *1	
Error message	
Contents of inquiry	

*1. Refer to "Confirming Machine information" of "Convenient using" then fill in necessary information. (☞ P.3-27)

Tx300P-1800B Operation Manual

May, 2021

MIMAKI ENGINEERING CO.,LTD.
2182-3 Shigeno-otsu, Tomi-shi, Nagano 389-0512 JAPAN

D203123-23-08052021

